

1st Order Transients – 3

extensions and examples

Other Stuff

- Time invariance; for switch at $t = t_0$

$$x(t) = x(\infty) + (x(t_0) - x_\infty)e^{-(t-t_0)/\tau} + x_\infty$$

- Unit step function

$$u(t) = \begin{cases} 0, & t < 0 \\ 1, & t > 0 \end{cases}$$

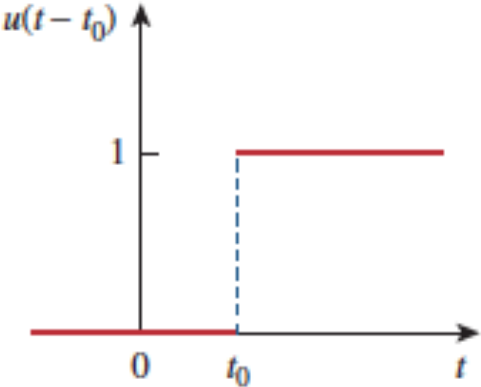
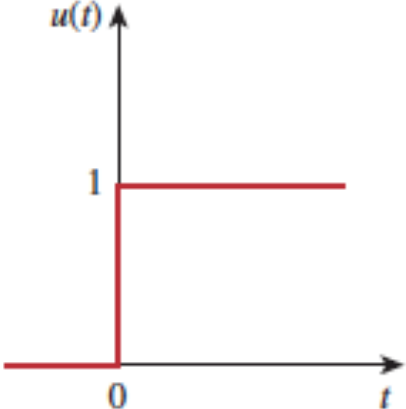

might replace the switch

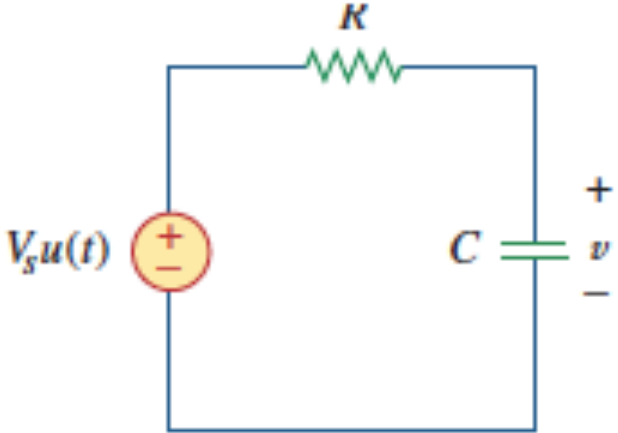
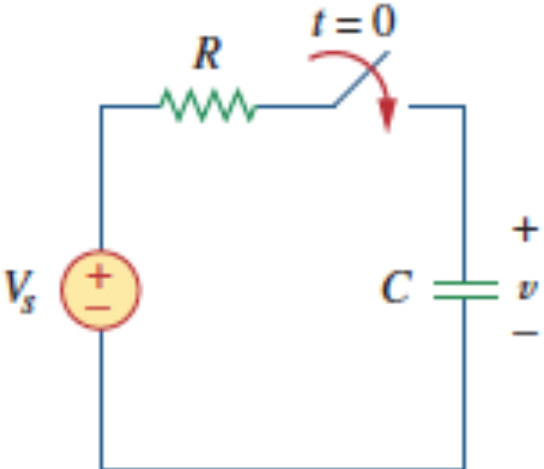

Example: note the 4 seconds

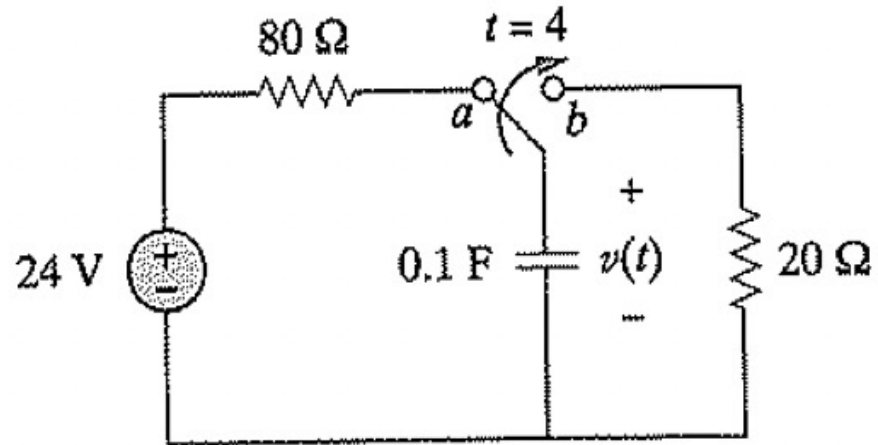

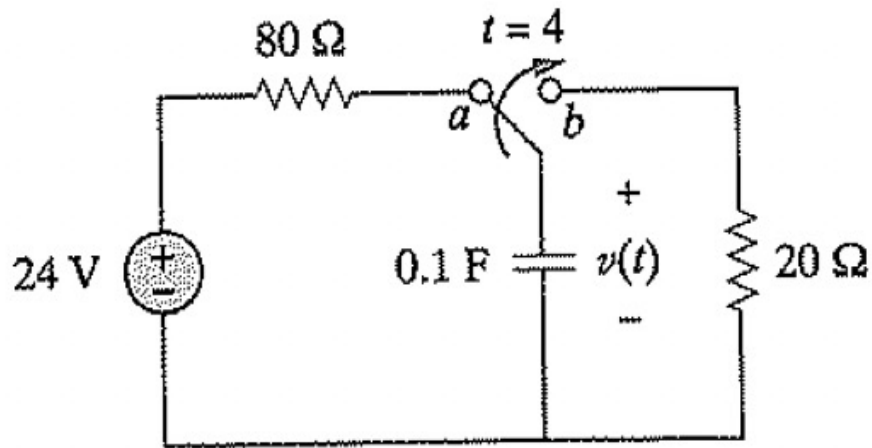

$a \rightarrow b$:

$$v(4) = 24\ \text{V}$$

$$v_{\infty} = 0\ \text{V}$$

$$R_{Th} = 20\ \Omega$$

$b \rightarrow a$:

$$v(4) = 0\ \text{V}$$

$$v_{\infty} = 24\ \text{V}$$

$$R_{Th} = 80\ \Omega$$

Example: switch opens

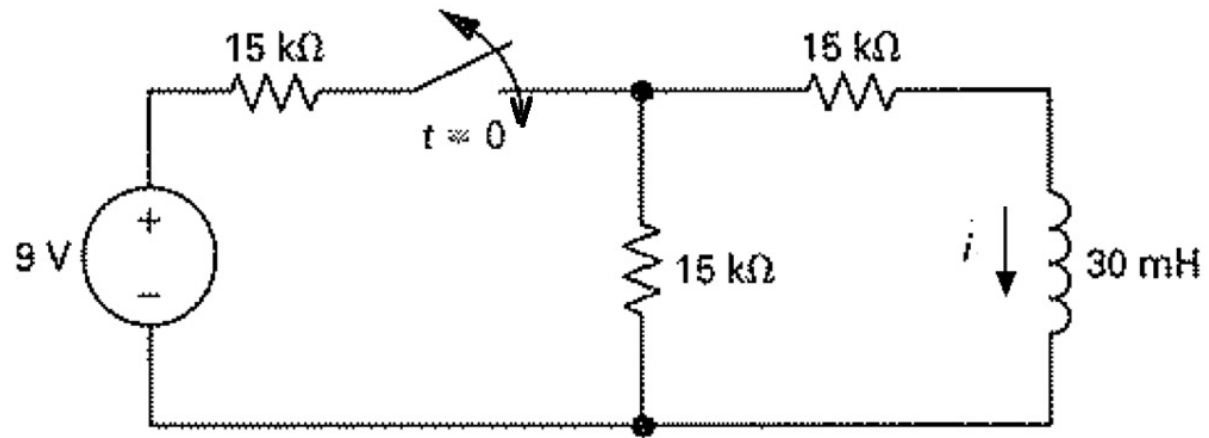

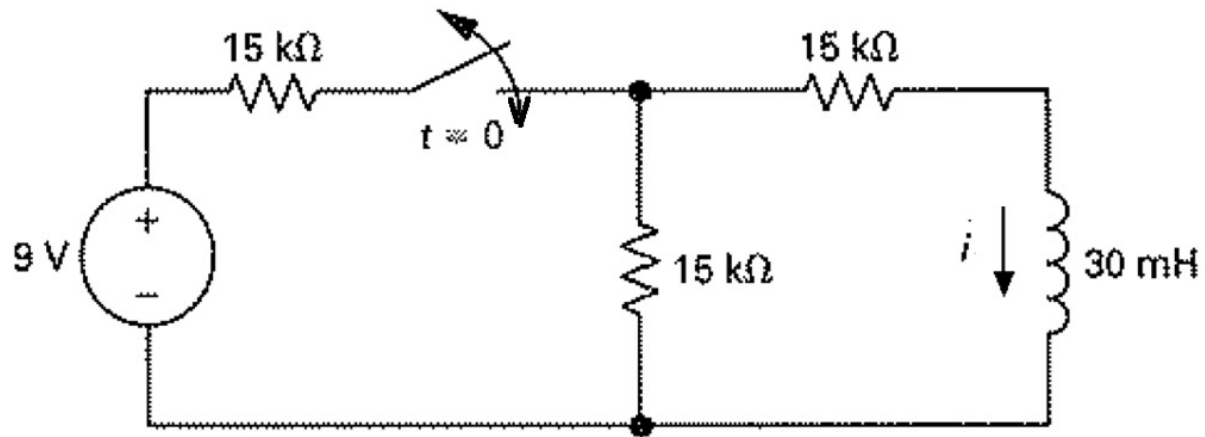

Opening at zero:

$$i_0 = 0.2 \text{ mA}$$

$$i_\infty = 0 \text{ mA}$$

$$R_{Th} = 30 \text{ k}\Omega$$

Example: switch closes

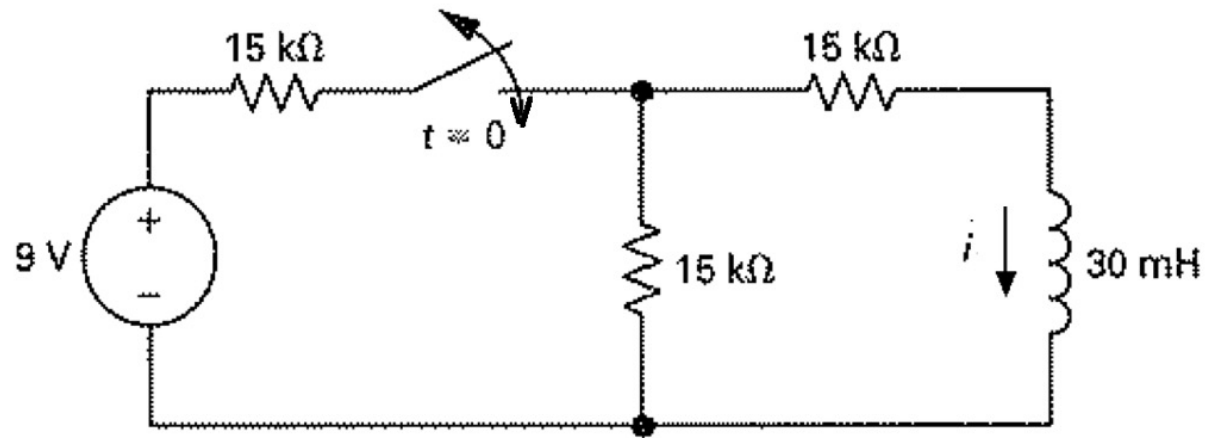

Closing at zero:

$$i_0 = 0 \text{ mA}$$

$$i = 0.2 \text{ mA}$$

$$R_{Th} = 22.5 \text{ k}\Omega$$

Example: switch moves from a to b

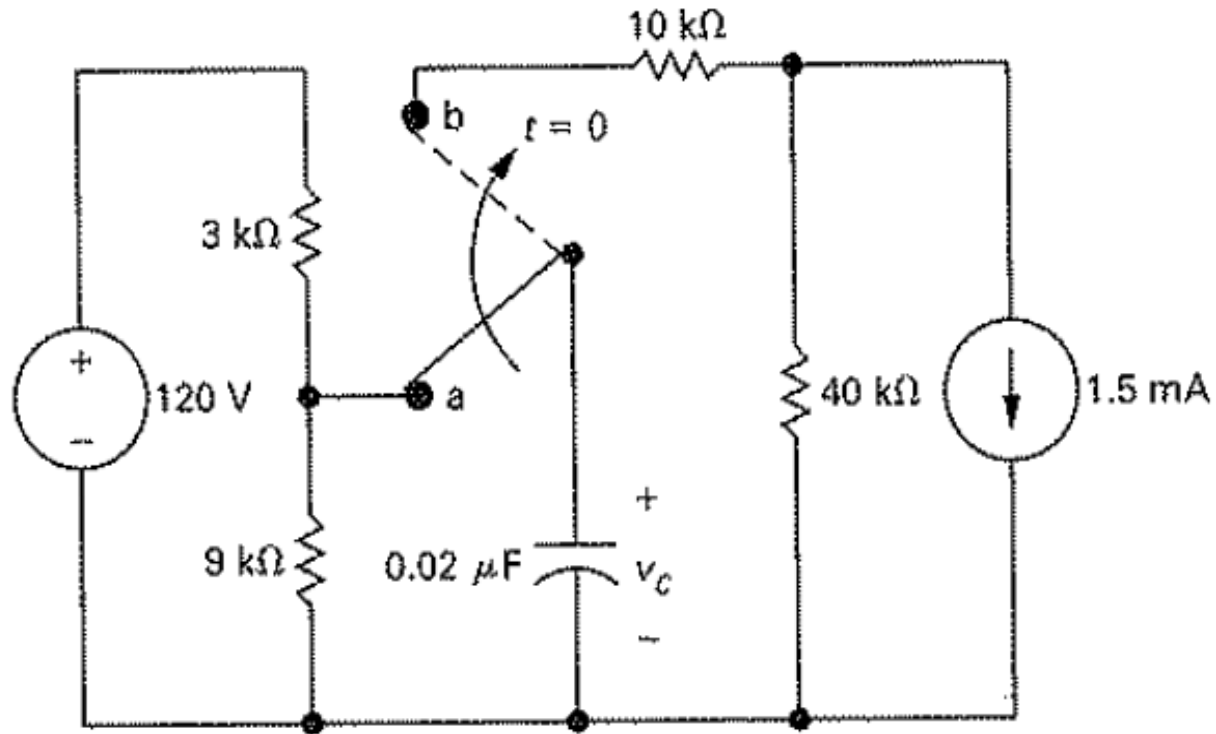

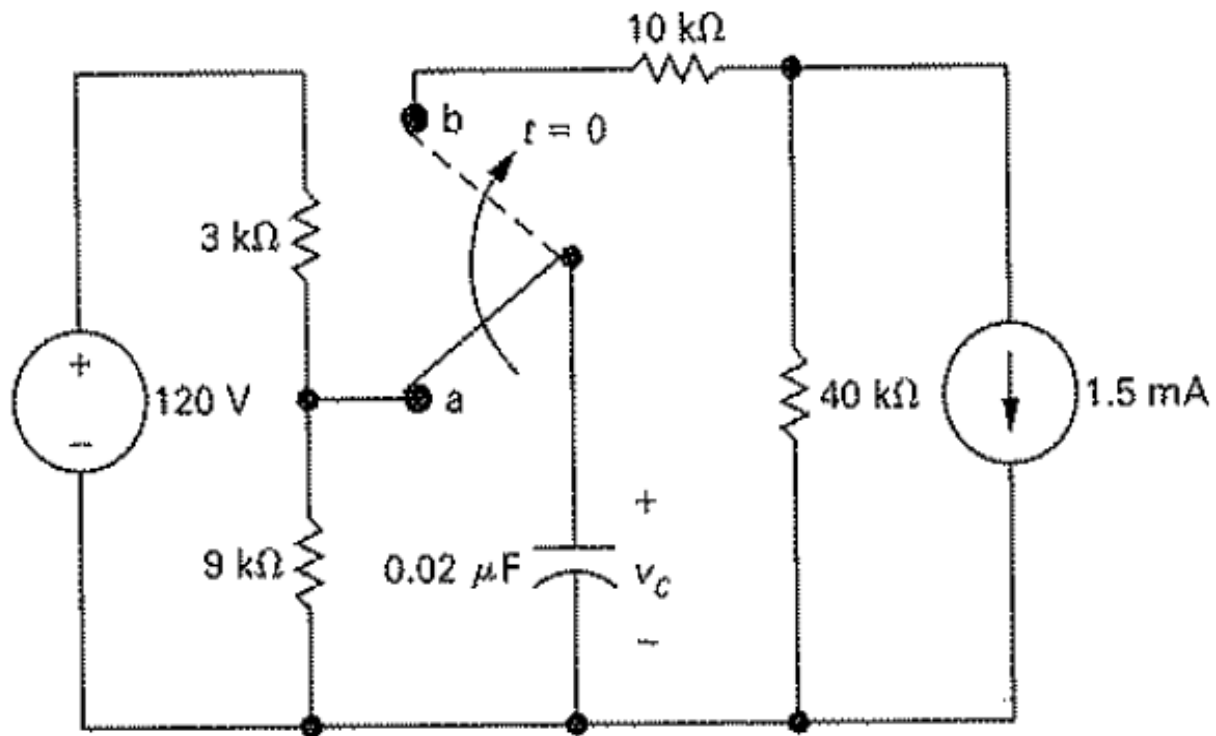

$$v_0 = 90 \text{ V}$$

$$v_\infty = -60 \text{ V}$$

$$R_{Th} = 50 \text{ k}\Omega$$

Practice problem: find $i(t)$

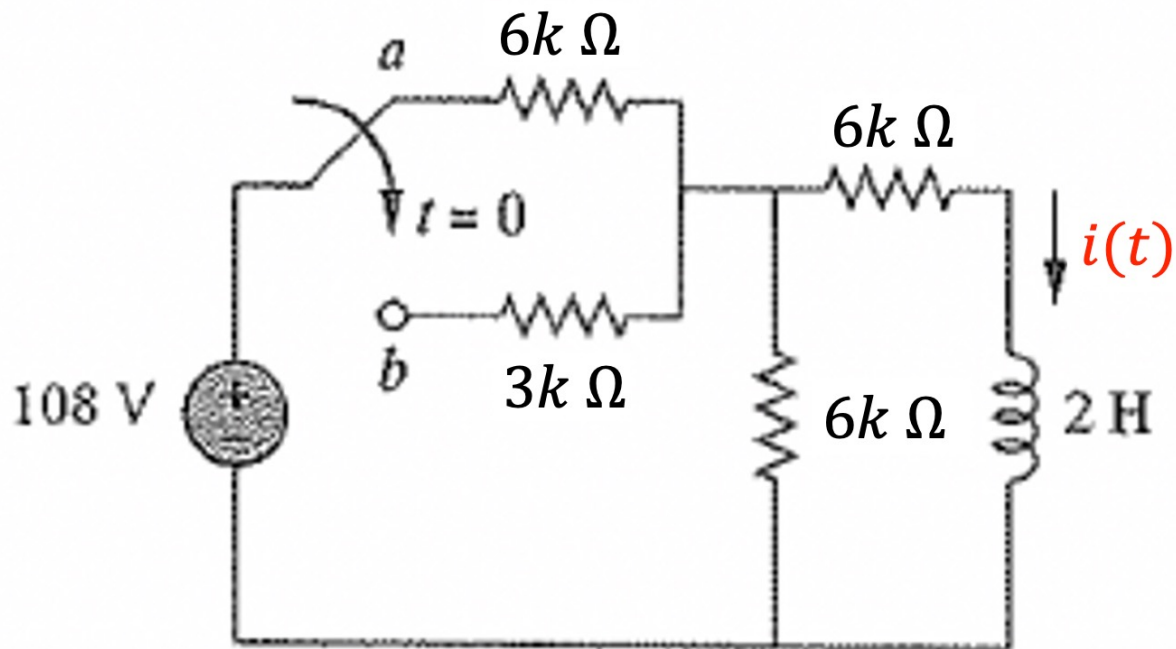

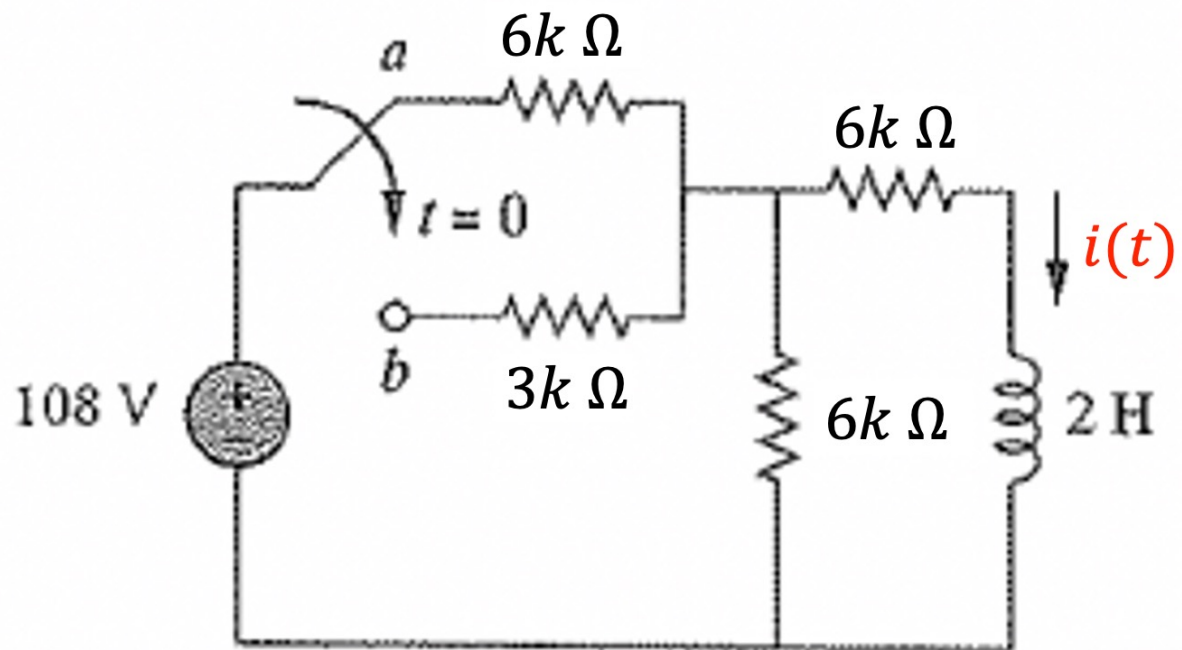

$$i(t) = -3 e^{-4000t} + 9\ \text{mA}$$

Practice problem:

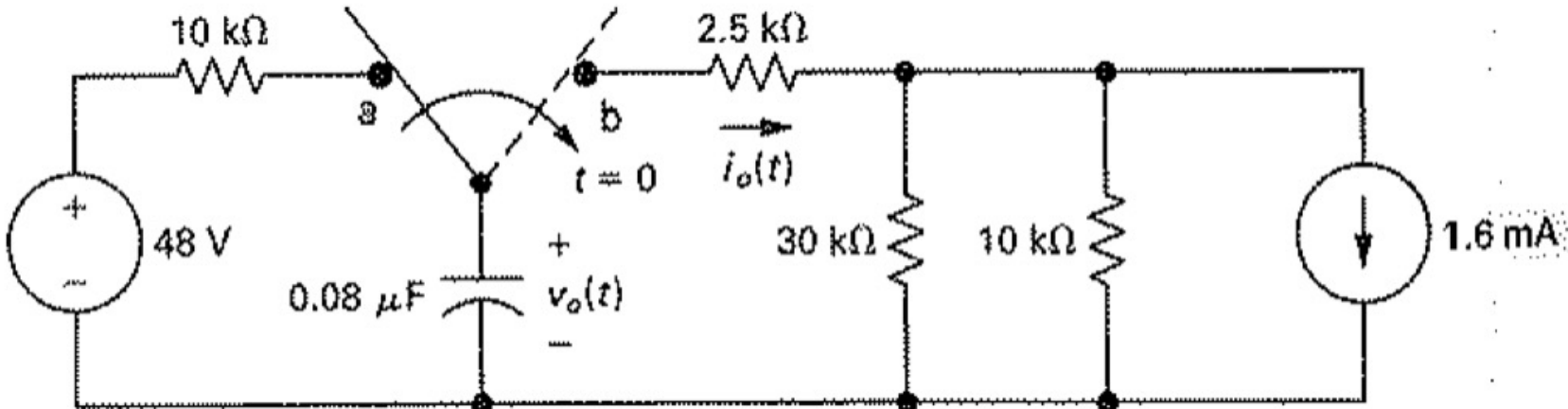

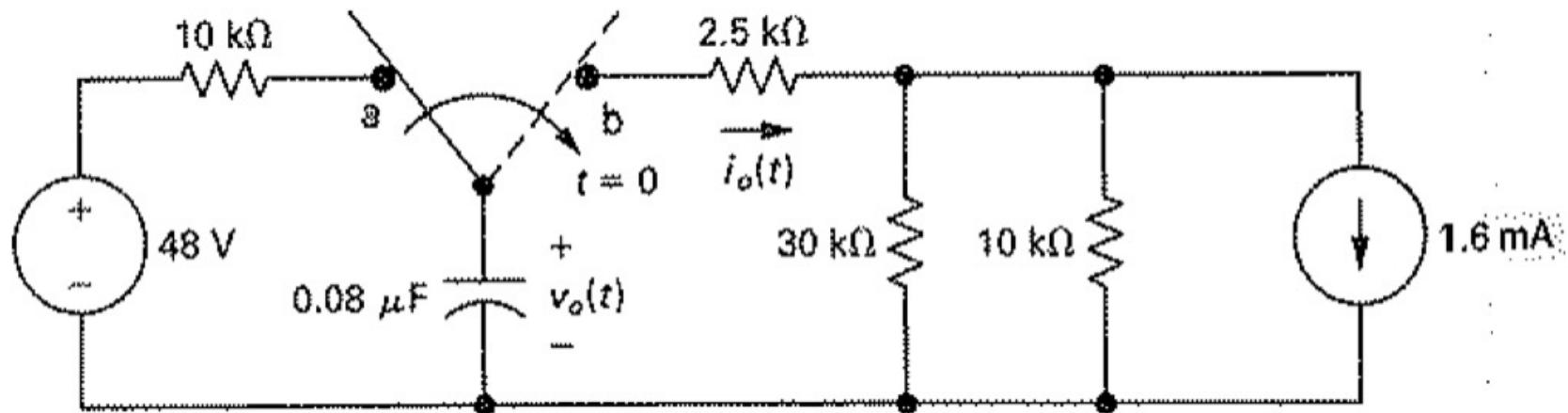

$$v(t) = 60 e^{-125t} - 12 \text{ V}$$

$$v(t) = 12 e^{-t} - 24 \text{ V}$$

Practice problem:

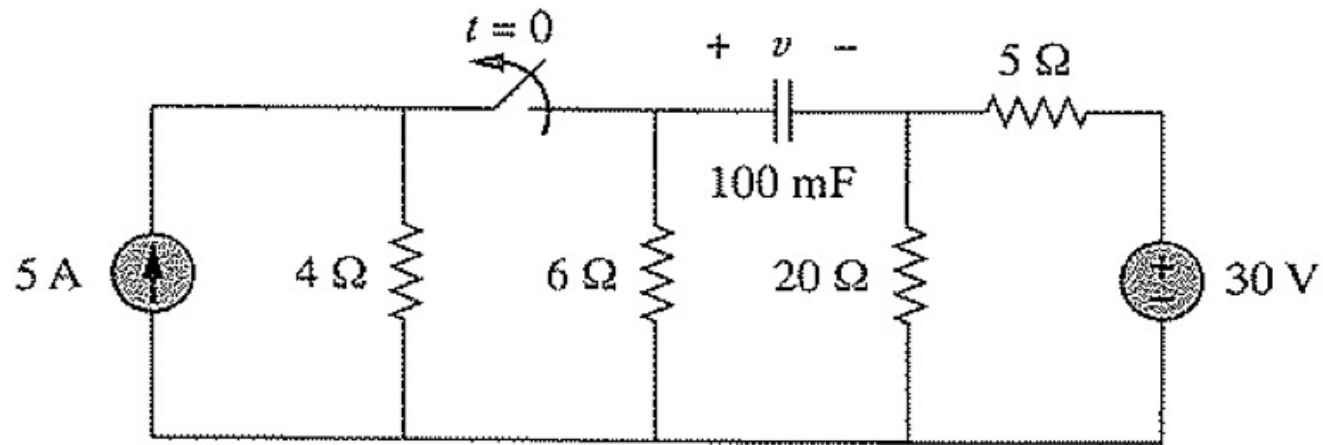

$$v(t) = -6e^{-t/21} + 10 \text{ V}$$

Practice problem:

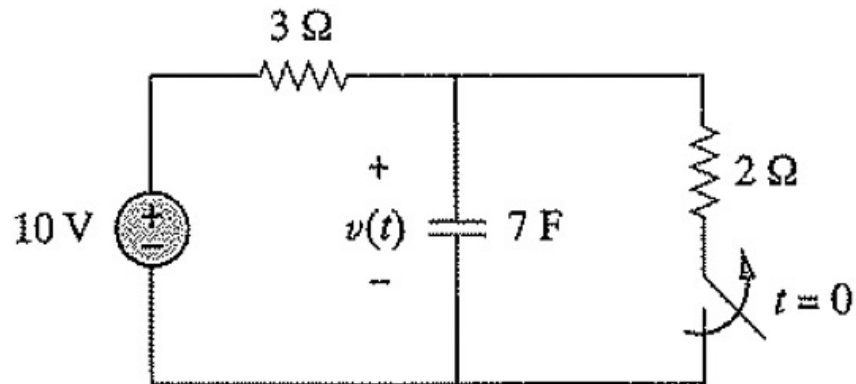

Practice problem:

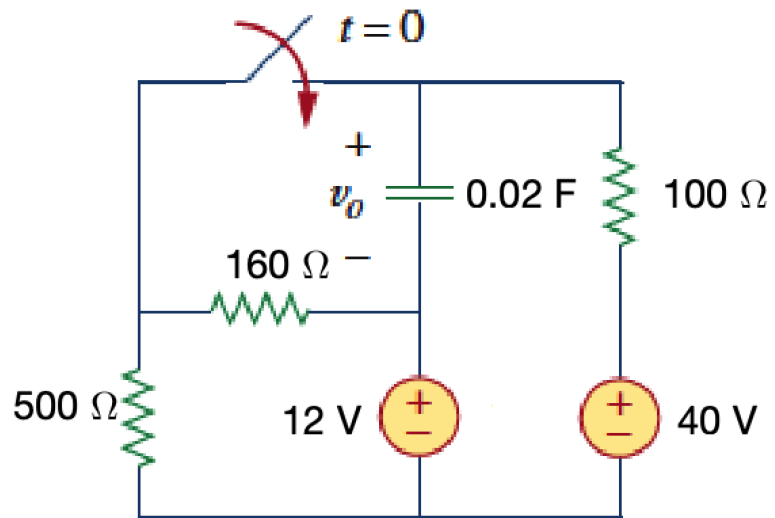

$$v(0) = 28\text{ V}$$

$$v_{\infty} = 14.0\text{ V}$$

$$R = 54.8\ \Omega$$