

Phasors – 3

how phasors help

Are they examples or practice?

Reconsider our Example

- Use a phasor model for the source (and again, just watch)

$$V_1(t) = \mathbf{V}e^{j\omega t}$$

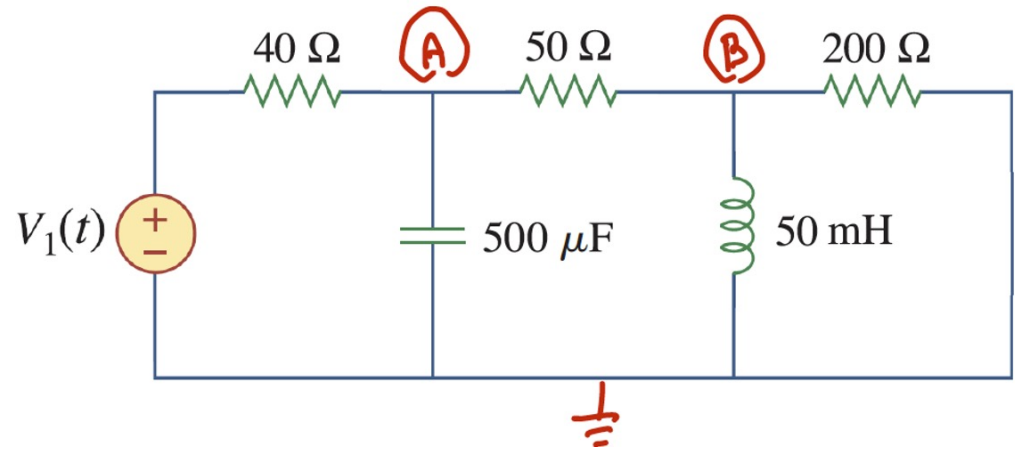

$$\frac{A(t) - V_1(t)}{40} + i_C(t) + \frac{A(t) - B(t)}{50} = 0$$

$$\frac{B(t)}{200} + i_L(t) + \frac{B(t) - A(t)}{50} = 0$$

- If our forcing function is

$$V_1(t) = \mathbf{V}e^{j\omega t}$$

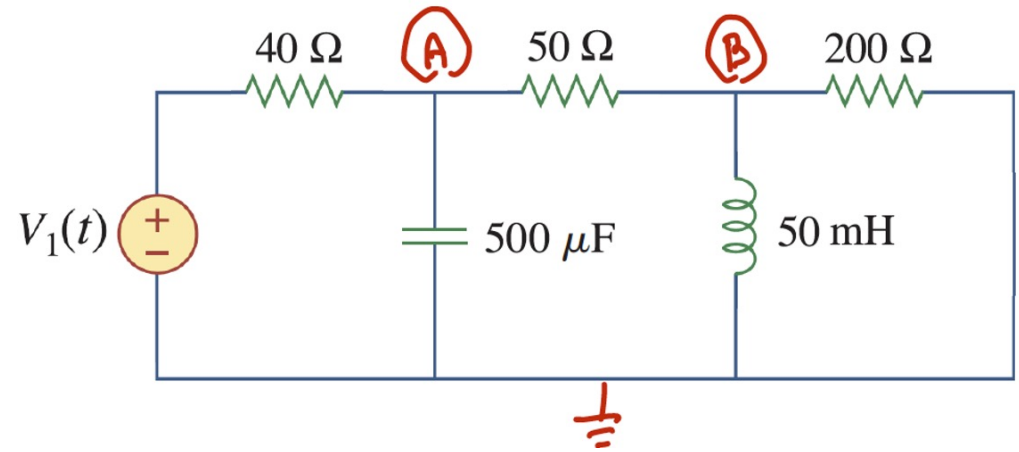

- Then the particular (steady-state) solution is also a complex exponential

Table 2.1 Method of Undetermined Coefficients

Term in $r(x)$	Choice for $y_p(x)$
$ke^{\gamma x}$	$Ce^{\gamma x}$
kx^n ($n = 0, 1, \dots$)	$K_n x^n + K_{n-1} x^{n-1} + \dots + K_1 x + K_0$
$k \cos \omega x$	$\left. \begin{array}{l} \\ \\ \end{array} \right\} K \cos \omega x + M \sin \omega x = \mathbf{K \cos (\omega t + \theta)}$
$k \sin \omega x$	

- Phasor notation:

$$A(t) \Rightarrow \mathbf{A}e^{j500t} \quad B(t) \Rightarrow \mathbf{B}e^{j500t} \quad V_1(t) \Rightarrow 10e^{j500t}$$

$$\mathbf{A} = Ae^{\phi} \quad \mathbf{B} = Be^{j\theta} \quad \mathbf{V}_1 = 10$$

- Consider the capacitor and inductor currents with this general model; if the voltage is $v(t) = \mathbf{V}e^{j\omega t}$ then

$$i_C(t) = C \frac{dv}{dt} = C \frac{d}{dt} (\mathbf{V}e^{j\omega t}) = j\omega C \mathbf{V}e^{j\omega t} = j \frac{1}{4} \mathbf{V}e^{j\omega t}$$

$$i_L(t) = \frac{1}{L} \int^t v(u) du = \frac{1}{L} \int^t \mathbf{V}e^{j\omega u} du = \frac{\mathbf{V}e^{j\omega t}}{j\omega L} = \frac{\mathbf{V}e^{j\omega t}}{j25}$$

- Back to the original node equations

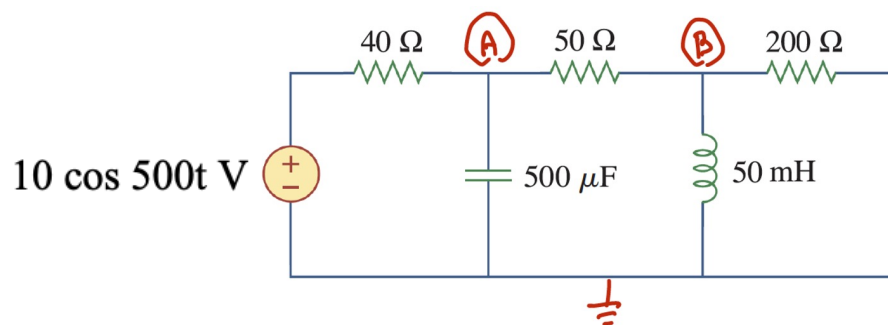

$$\frac{\mathbf{A}e^{j500t} - 10e^{j500t}}{40} + j\frac{1}{4}\mathbf{A}e^{j500t} + \frac{\mathbf{A}e^{j500t} - \mathbf{B}e^{j500t}}{50} = 0$$

$$\frac{\mathbf{B}e^{j500t}}{200} + \frac{\mathbf{A}e^{j500t}}{j25} + \frac{\mathbf{B}e^{j500t} - \mathbf{A}e^{j500t}}{50} = 0$$

- Can cancel the common e^{j500t} term

- Result is a set of simultaneous equations with complex coefficients

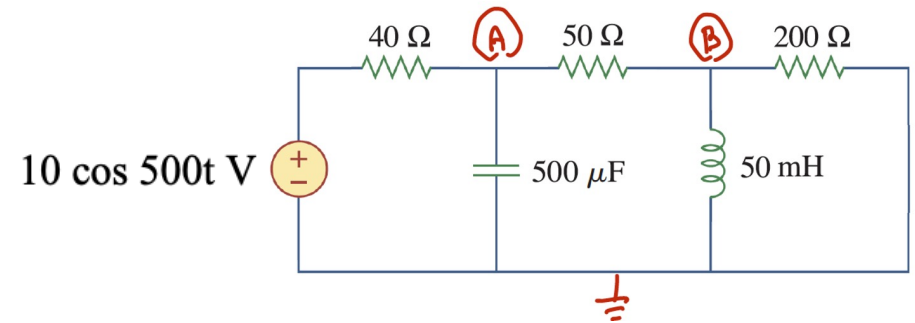

$$\frac{\mathbf{A} - 10}{40} + j \frac{\mathbf{A}}{4} + \frac{\mathbf{A} - \mathbf{B}}{50} = 0$$

$$\frac{\mathbf{B}}{200} + \frac{\mathbf{A}}{j25} + \frac{\mathbf{B} - \mathbf{A}}{50} = 0$$

- Solve using various methods (Cramer, matrix inverse, etc)

- Solving

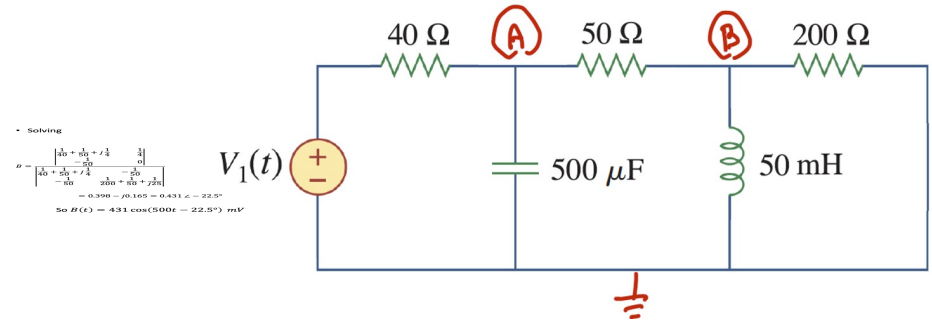

$$B = \frac{\begin{vmatrix} \frac{1}{40} + \frac{1}{50} + j\frac{1}{4} & \frac{1}{4} \\ -\frac{1}{50} & 0 \end{vmatrix}}{\begin{vmatrix} \frac{1}{40} + \frac{1}{50} + j\frac{1}{4} & -\frac{1}{50} \\ -\frac{1}{50} & \frac{1}{200} + \frac{1}{50} + \frac{1}{j25} \end{vmatrix}}$$

$$= 0.398 - j0.165 = 0.431 \angle -22.5^\circ$$

$$\text{So } B(t) = 431 \cos(500t - 22.5^\circ) \text{ mV}$$

Same as last time !!

So How to Use Phasors?

- Extend sinusoidal voltages/currents to phasors (complex)

$$V_s \cos(\omega t + \phi) \Rightarrow \mathbf{V} = V_s e^{j\phi}$$

$$I_s \cos(\omega t + \phi) \Rightarrow \mathbf{I} = I_s e^{j\phi}$$

- Convert components (R,L,C) to impedances

$$Z = \begin{cases} R & \text{resistor} \\ j\omega L & \text{inductor} \\ \frac{1}{j\omega C} = -j \frac{1}{\omega C} & \text{capacitor} \end{cases}$$

- Solve the problem using Ohm's Law, KVL/KCL, ...
- Convert back

$$B \angle \theta \Rightarrow B \cos(\omega t + \theta)$$

Example:

- Convert problem
- Combine in series
- Apply Ohm's Law
- Convert back

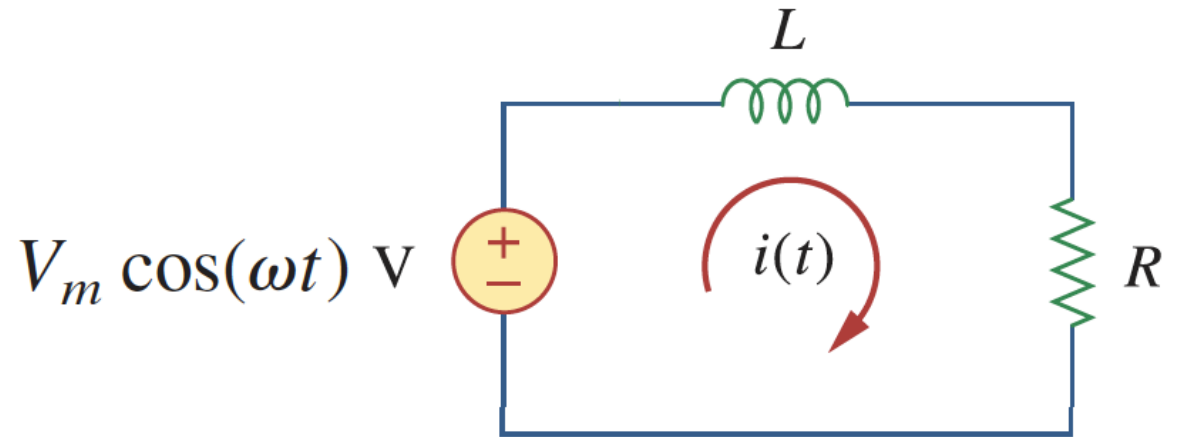

$$i(t) = \frac{V_m}{\sqrt{R^2 + \omega^2 L^2}} \cos\left(\omega t - \tan^{-1} \frac{\omega L}{R}\right)$$

Example (again):

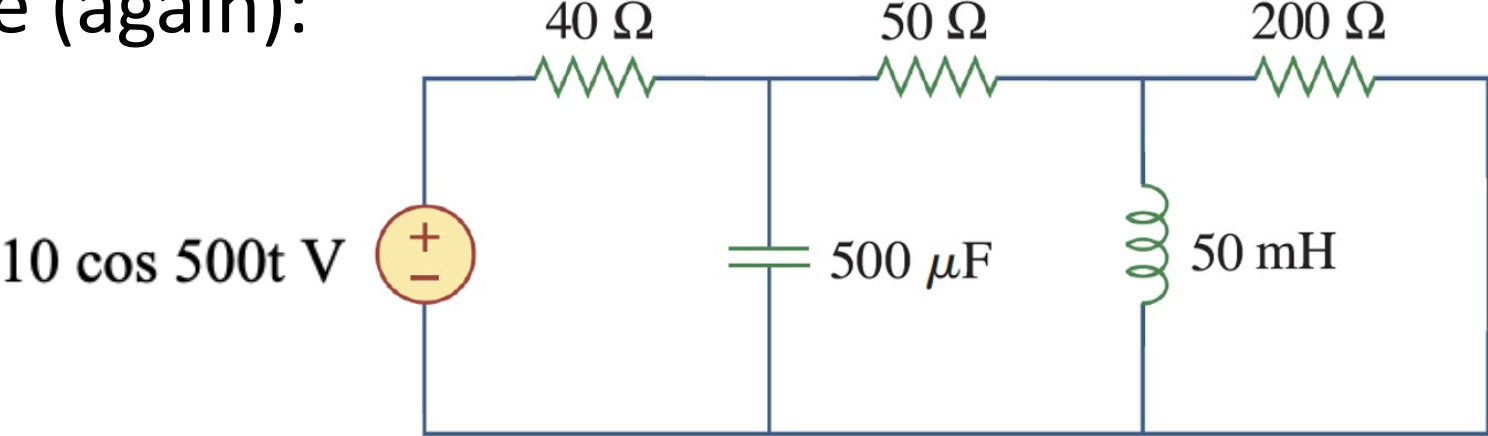

- Previous equations:

$$\frac{\mathbf{A} - 10}{40} + j\frac{\mathbf{A}}{4} + \frac{\mathbf{A} - \mathbf{B}}{50} = 0$$

$$\frac{\mathbf{B}}{200} + \frac{\mathbf{A}}{j25} + \frac{\mathbf{B} - \mathbf{A}}{50} = 0$$

Example: find the current $i(t)$

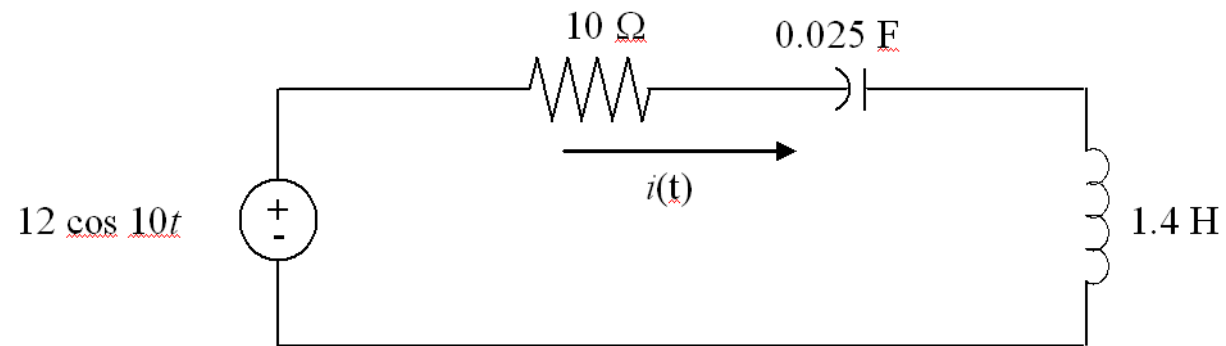

$$0.848 \cos(10t - 45^\circ) \text{ A}$$

Example: find $V(t)$
by voltage division

$$v_g(t) = 75 \cos 20,000t \text{ V}$$

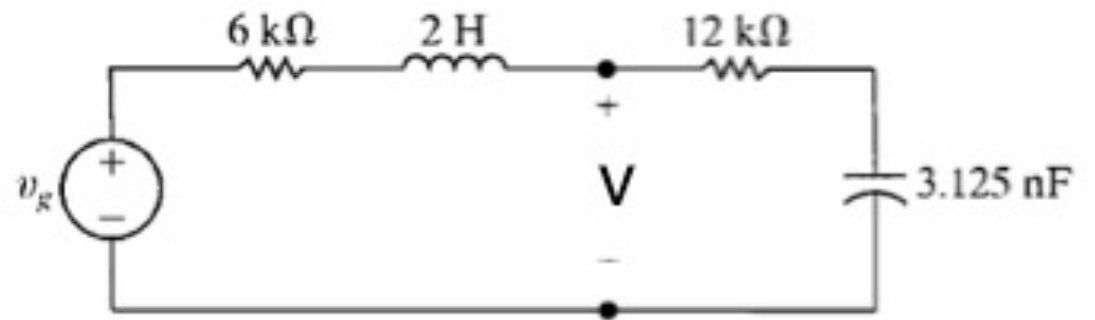

$$50 \cos(20,000t - 106^\circ) \text{ V}$$

Example: find v

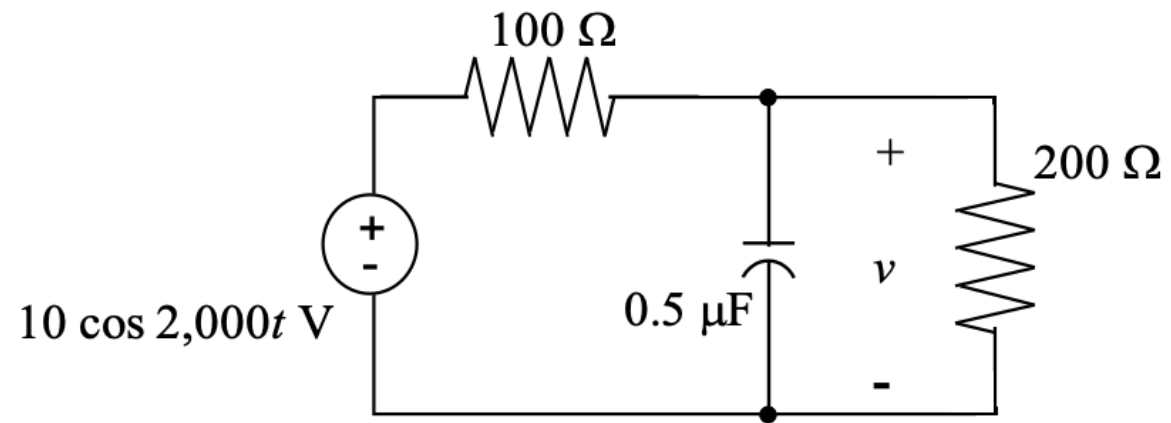

$$6.65 \cos(2000t - 3.81^\circ) \text{ V}$$

Practice problem: find the current if

$$v_s(t) = 750 \cos 5000t$$

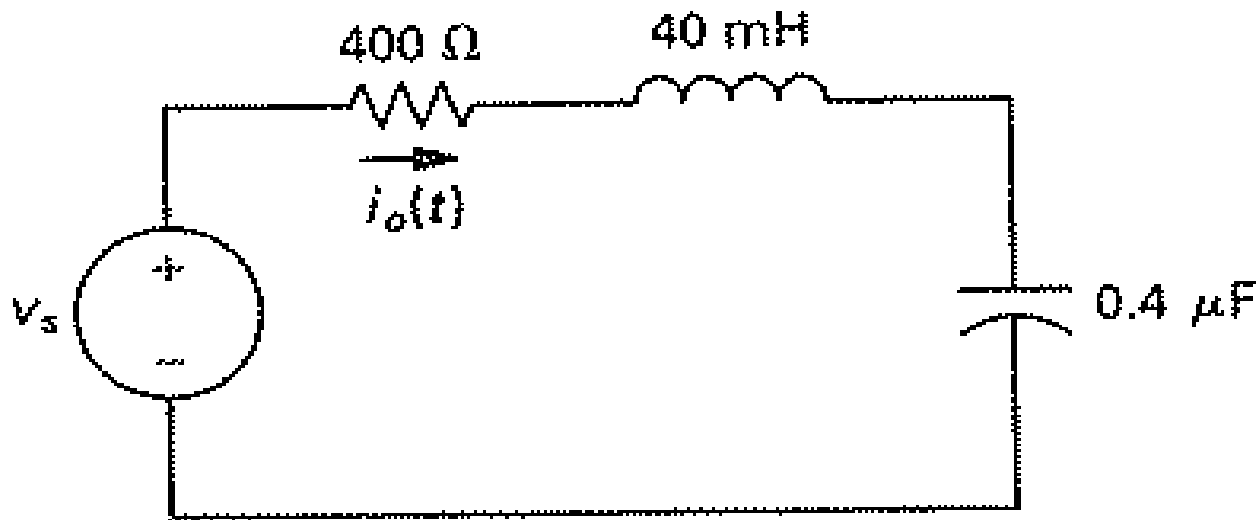

$$1.5 \cos(5000t + 36.9^\circ) \text{ A}$$

Practice problem: if $v_g(t) = 75 \cos 5000t$ V, find the time expression for v_o

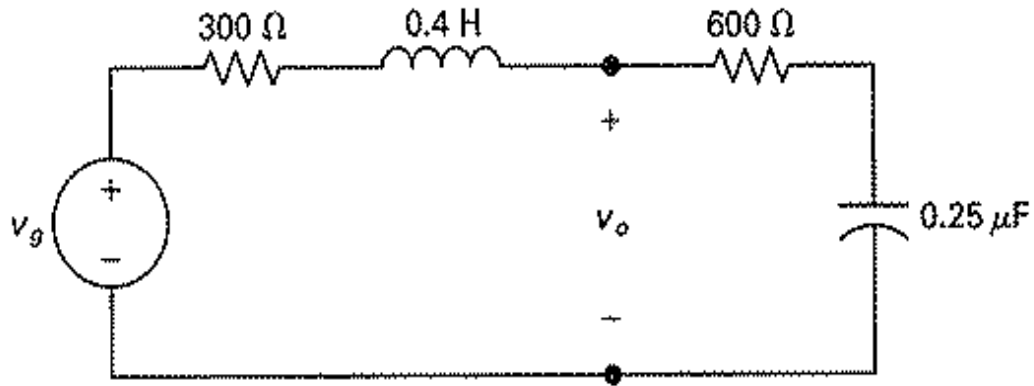

$$130 \cos(5000t - 93.4^\circ) \text{ V}$$

Practice problem: find v

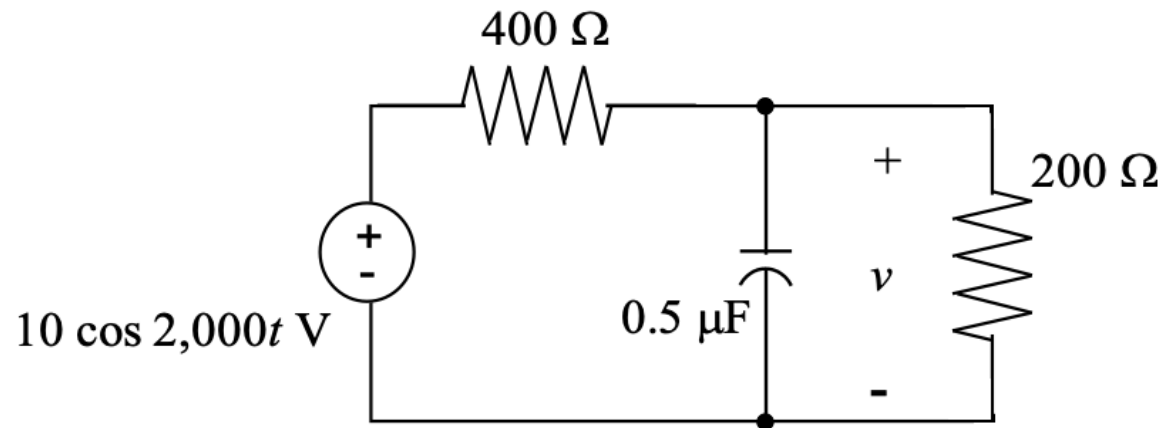

$$3.30 \cos(2000t - 7.60^\circ) \text{ V}$$