

Phasors – 2

RLC circuits

RLC Circuits

- How do we analyze this?

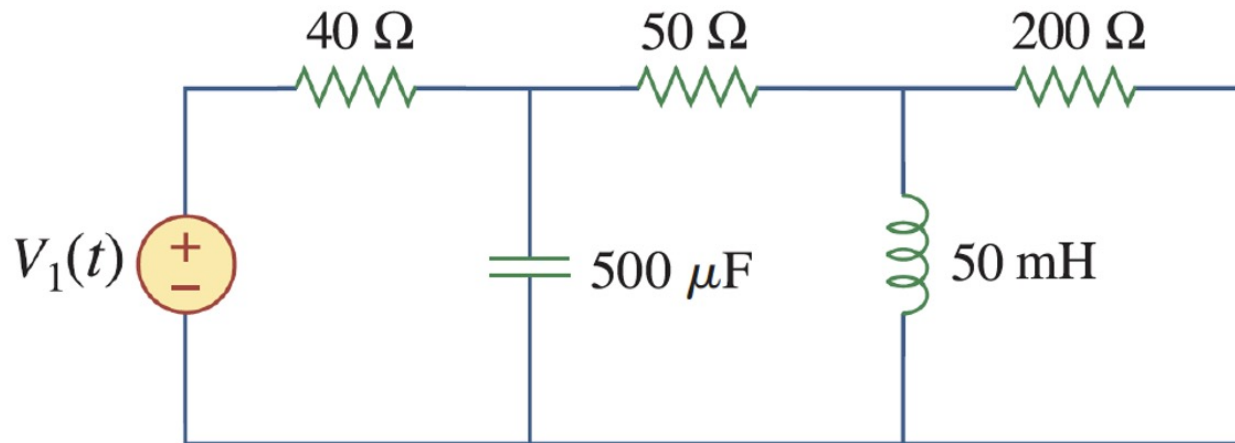

- Watch the following (details posted)

- If only resistors, then node analysis would be the obvious choice

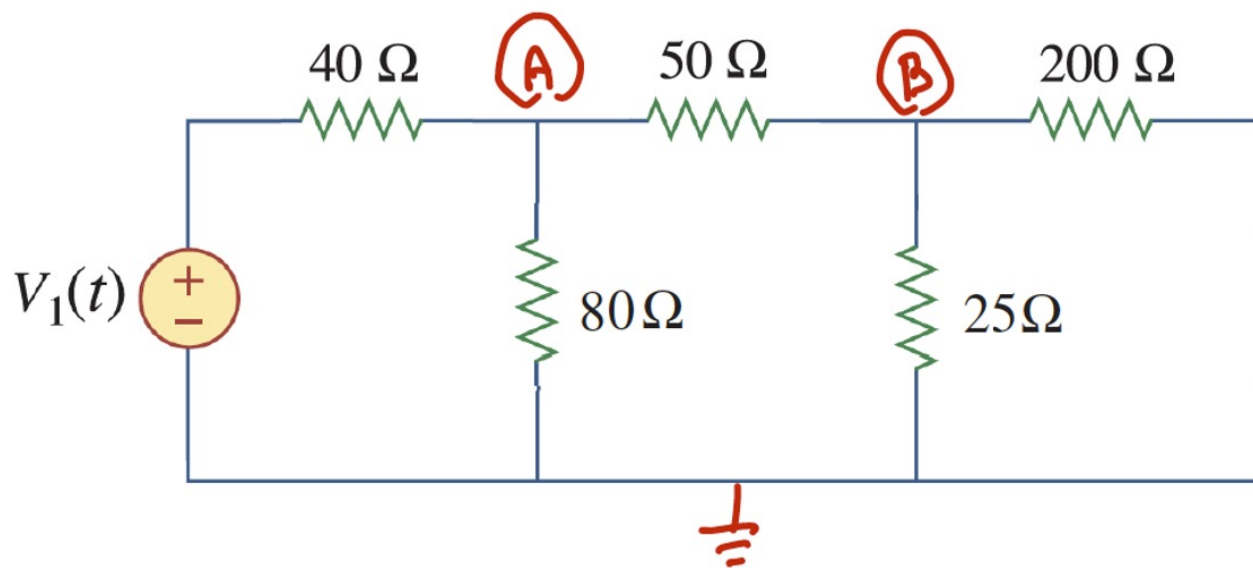

$$\frac{A - V_1(t)}{40} + \frac{A}{80} + \frac{A - B}{50} = 0$$

$$\frac{B}{200} + \frac{B}{25} + \frac{B - A}{50} = 0$$

- Let's try the same using L & C definitions

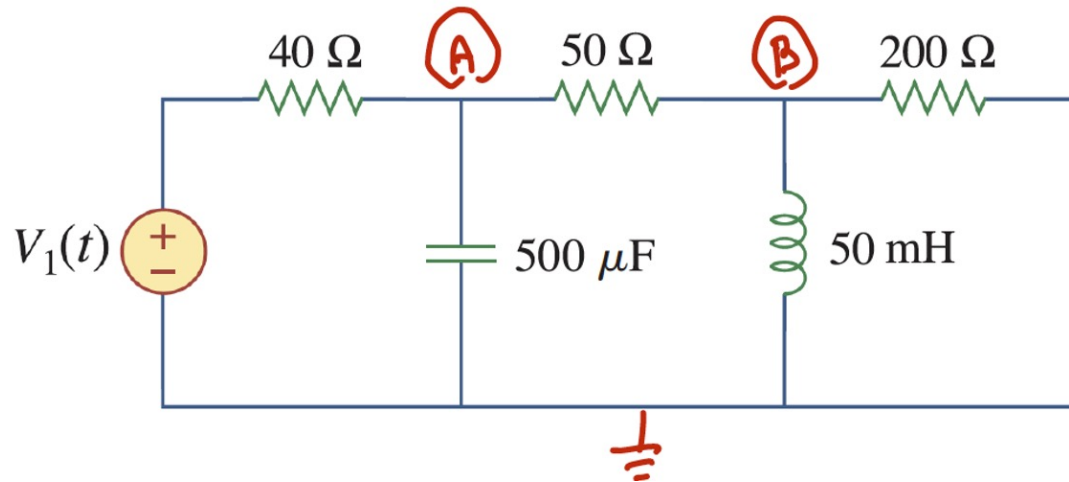

- Node A:

$$\frac{A(t) - V_1(t)}{40} + i_C(t) + \frac{A(t) - B(t)}{50} = 0$$

$$0.0005 \frac{dA(t)}{dt}$$

$$\frac{dA(t)}{dt} + 90 A(t) - 40 B(t) = 50 V_1(t)$$

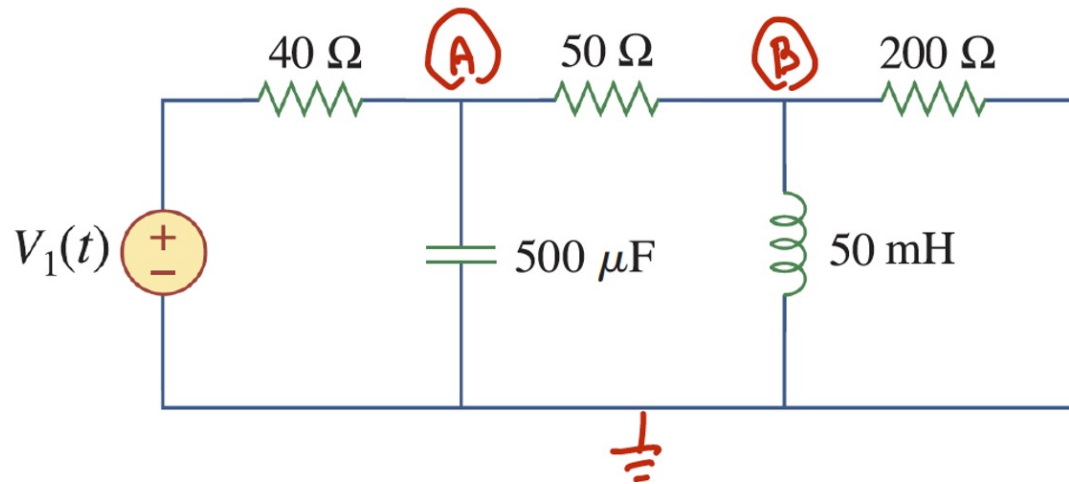

- Node B:

$$\frac{B(t)}{200} + i_L(t) + \frac{B(t) - A(t)}{50} = 0$$



 $\frac{1}{L} \int_0^t B(s) ds$ and take a time derivative

$$\frac{1}{200} \frac{dB(t)}{dt} + \frac{1}{0.05} B(t) + \frac{1}{50} \frac{dB(t)}{dt} - \frac{1}{50} \frac{dA(t)}{dt} = 0$$

$$\frac{dB(t)}{dt} + 800 B(t) - 0.8 \frac{dA(t)}{dt} = 0$$

- Result is a pair of differential equations

$$\frac{dA(t)}{dt} + 90 A(t) - 40 B(t) = 50 V_1(t)$$

$$\frac{dB(t)}{dt} + 800 B(t) - 0.8 \frac{dA(t)}{dt} = 0$$

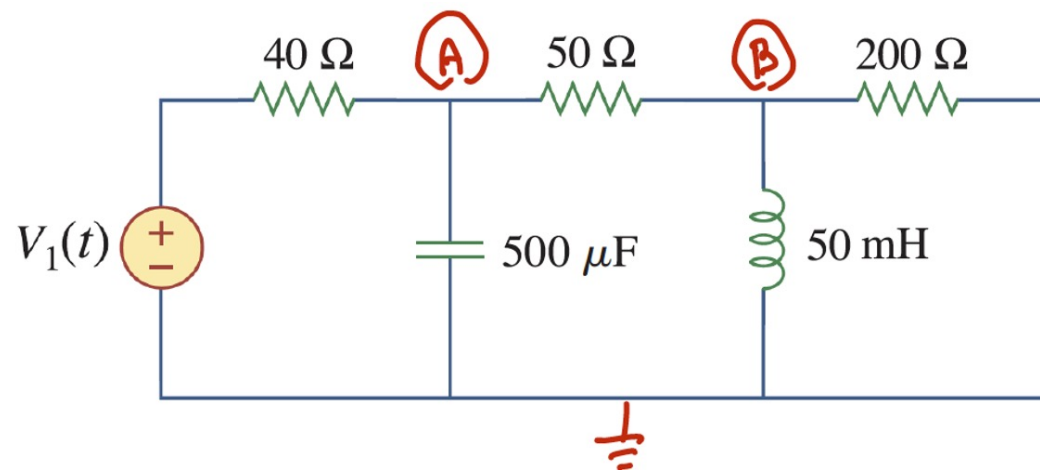

- How to solve?

$$\frac{dA(t)}{dt} + 90 A(t) - 40 B(t) = 50 V_1(t)$$

$$\frac{dB(t)}{dt} + 800 B(t) - 0.8 \frac{dA(t)}{dt} = 0$$

- Linear
- Constant coefficient
- Homogeneous and particular solutions
- Steps:
 1. Form a single equation from the pair
 2. Find the homogeneous solution
 3. Find the particular solution
 4. Solve for the unknowns

- Form a single equation from the pair
 - Some magic yields

$$\frac{d^2 A(t)}{dt^2} + 858 \frac{dA(t)}{dt} + 72,000 A(t) = 50 \frac{dV_1(t)}{dt} + 40,000 V_1(t)$$

and

$$\frac{d^2 B(t)}{dt^2} + 858 \frac{dB(t)}{dt} + 72,000 B(t) = 40 \frac{dV_1(t)}{dt}$$

- Continue with $B(t)$

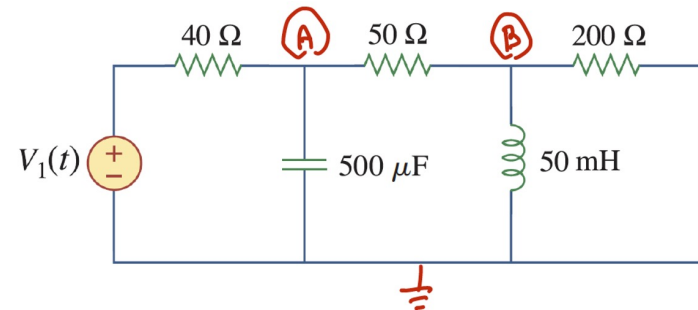

$$\frac{d^2 B(t)}{dt^2} + 858 \frac{dB(t)}{dt} + 72,000 B(t) = 40 \frac{dV_1(t)}{dt}$$

2. Find the homogeneous solution

$$\frac{d^2 B(t)}{dt^2} + 858 \frac{dB(t)}{dt} + 72,000 B(t) = 0$$

– Characteristic polynomial: $s^2 + 858s + 72,000 = 0$

• Roots, $s = -94.3, -764$

$$B_{homogeneous}(t) = a_1 e^{-94.3t} + a_2 e^{-764t}$$

– Since real parts are negative, then

$$\lim_{t \rightarrow \infty} B_{homogeneous}(t) = 0 \Rightarrow \text{“transient”}$$

3. Find the particular solution – depends upon the rhs
 – Table lookup:

Table 2.1 Method of Undetermined Coefficients

Term in $r(x)$	Choice for $y_p(x)$
$ke^{\gamma x}$	$Ce^{\gamma x}$
kx^n ($n = 0, 1, \dots$)	$K_n x^n + K_{n-1} x^{n-1} + \dots + K_1 x + K_0$
$k \cos \omega x$	$\left. \begin{array}{l} K \cos \omega x + M \sin \omega x \\ K \cos \omega x + M \sin \omega x \end{array} \right\} = \mathbf{K \cos (\omega t + \theta)}$
$k \sin \omega x$	
$ke^{\alpha x} \cos \omega x$	$\left. \begin{array}{l} K \cos \omega x + M \sin \omega x \\ K \cos \omega x + M \sin \omega x \end{array} \right\} e^{\alpha x} (K \cos \omega x + M \sin \omega x)$
$ke^{\alpha x} \sin \omega x$	

- Focus on sinusoidal sources – why? Let

$$V_1(t) = 10 \cos(500t) \text{ volts}$$

4. Find the unknowns K and θ

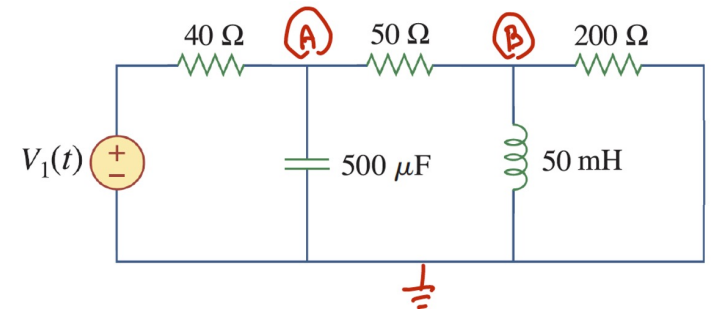

$$\frac{d^2 B(t)}{dt^2} + 858 \frac{dB(t)}{dt} + 72,000 B(t) = -40,000 \sin 500t$$

$$B(t) = K \cos(500t + \theta)$$

– Grind through calculus, algebra, and trig

$$B_{steady-state}(t) = 431 \cos(500t - 22.5^\circ) \text{ mV}$$

- **Summary** – while it works, the method is tedious and we need want a better approach → the “phasor” method

The Phasor Concept

Extend a sinusoid with an imaginary part

$$x(t) = A \cos(\omega t + \phi)$$



$$x(t) = A \cos(\omega t + \phi) + jA \sin(\omega t + \phi)$$

$$= A e^{j(\omega t + \phi)}$$

Euler's identity

$$= \underbrace{A e^{j\phi}} \quad \underbrace{e^{j\omega t}}$$

= **A**, the
"phasor"

Rotating
part

Bold for
complex

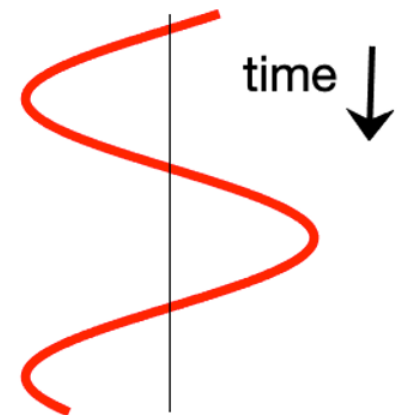
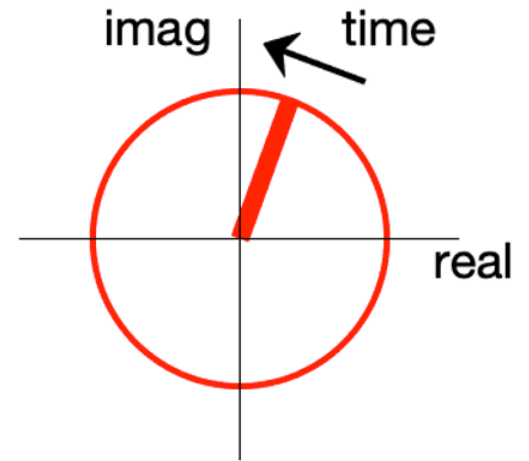

- Time functions to phasors

$$x(t) = 10 \cos \omega t$$

$$\Rightarrow \mathbf{X}e^{j\omega t} = 10 \cos \omega t + j10 \sin \omega t$$

$$= 10(\cos \omega t + j \sin \omega t)$$

$$= 10 e^{j\omega t}$$

$$\text{so } \mathbf{X} = 10 = 10 \angle 0^\circ$$

- If $x(t) = 10 \cos(500t + 30^\circ)$ find the phasor

$$\mathbf{X}e^{j\omega t} = 10 \cos(500t + 30^\circ) + j10 \sin(500t + 30^\circ)$$

$$= 10(\cos 500t \cos 30^\circ - \sin 500t \sin 30^\circ) + j10(\cos 500t \sin 30^\circ + \sin 500t \cos 30^\circ)$$

$$= 10 \cos 500t (\cos 30^\circ + j \sin 30^\circ) + j10 \sin 500t (\cos 30^\circ + j \sin 30^\circ)$$

$$= 10(\cos 30^\circ + j \sin 30^\circ)(\cos 500t + j \sin 500t)$$

$$= \underbrace{(8.66 + j5)}_{\mathbf{X}} e^{j500t} = \underbrace{10e^{j30\pi/180}}_{\mathbf{X}} e^{j500t}$$

\mathbf{X}

Also, $10\angle 30^\circ$

\mathbf{X}

- If $x(t) = 4 \cos(\omega t + 45^\circ)$ then

$$\mathbf{X} = 4 \angle 45^\circ$$

$$= 4 \cos 45^\circ + j 4 \sin 45^\circ$$

$$= 2\sqrt{2} + j 2\sqrt{2}$$

$$= 2\sqrt{2} (1 + j)$$

And back again

- If $\mathbf{X} = 4 + j3 = \sqrt{4^2 + 3^2} \angle \tan^{-1} \frac{3}{4} = 5 \angle 36.9^\circ$

$$\text{then } x(t) = 5 \cos(\omega t + 36.9^\circ)$$

- If $\mathbf{X} = -8 - j3 = \sqrt{(-8)^2 + (-3)^2} \angle \tan^{-1} \frac{-3}{-8}$
 $= \sqrt{73} \angle -162^\circ$

$$\text{then } x(t) = \sqrt{73} \cos(\omega t - 162^\circ)$$

Practice problem: If $x(t) = 100 \cos(100t + 102^\circ)$,
find **X**

$$-20.6 + j97.8$$

Practice problem: If $x(t) = 12 \cos(100t + 12^\circ)$, find
X

$$11.7 + j2.49$$

Practice problem: If $x(t) = 12 \sin(100t + 12^\circ)$, find
X

$$2.49 - j211.7$$

Practice problem: If $x(t) = 13 \cos(100t - 202.6^\circ)$,
find \mathbf{X}

$$-12 + j5$$

Practice problem: If $\mathbf{X} = 4 + j2$, find $x(t)$

$$4.47 \cos(\omega t + 26.6^\circ)$$

Practice problem: If $\mathbf{X} = 7.5\angle 31^\circ$, find $x(t)$

$$47.5 \cos(\omega t + 31^\circ)$$