

0.35 μ

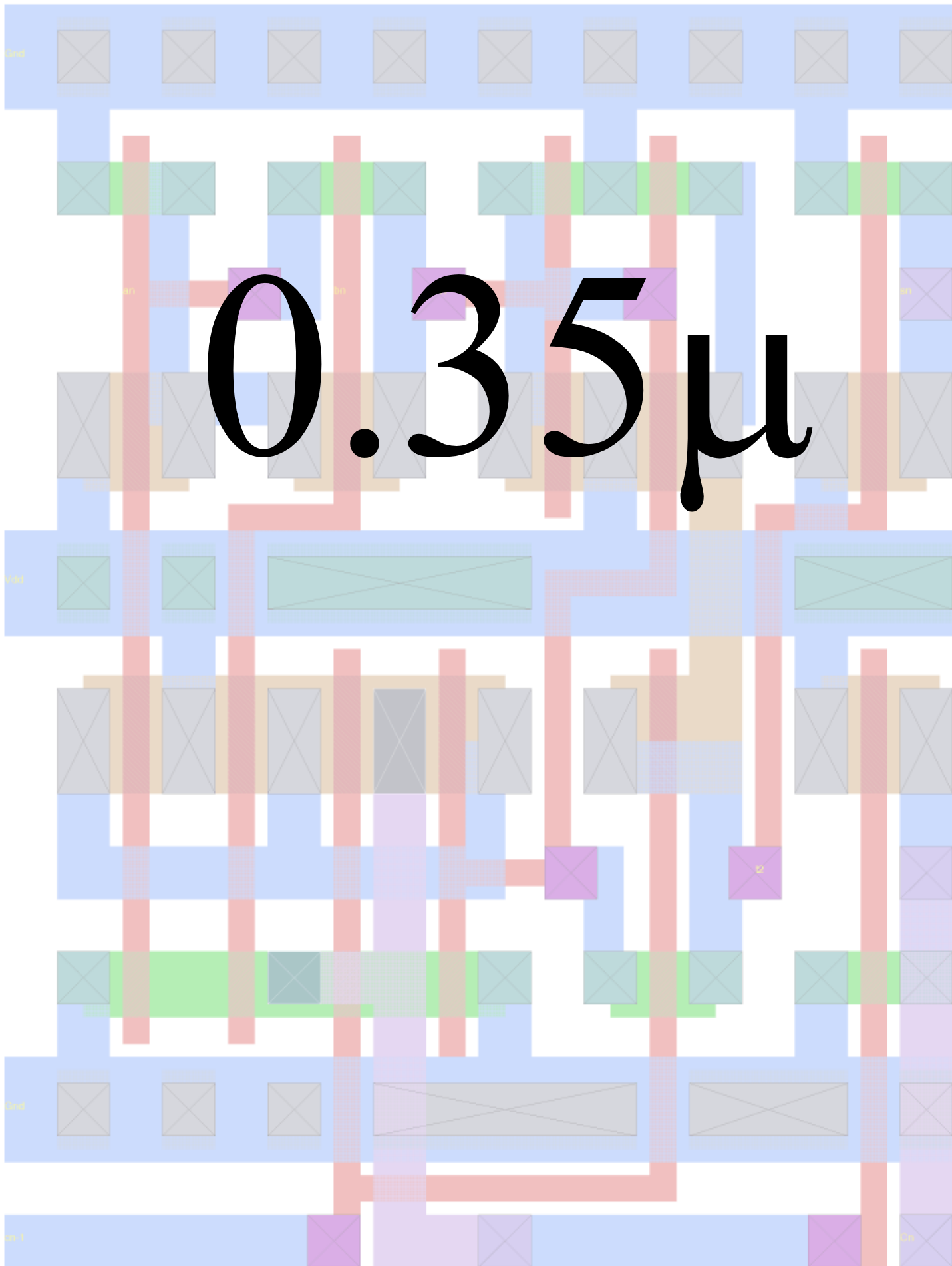

Table of Contents

Design Rules

Cell Library

Inverters, Buffers, Delays

- Inverter
- Delay-Inverter
- Buffer 3x
- Buffer 4x
- Buffer 6x
- Buffer 8x
- Buffer 10x
- Buffer 12x

Basic Logic Gates

- NAND, 2 input
- NAND, 4 input
- AND, 2 input
- NOR, 2 input
- OR, 2 input
- XNOR
- XOR

Pass-Switches, Latches, Flip-Flops

- Pass switch
- Latch
- D-FF, dynamic, negative edge-triggered
- D-FF, dynamic, negative edge-triggered, asynchronous clear (L)
- D-FF, dynamic, negative edge-triggered, asynchronous clear (H)

Adders

- Full adder, 1 Bit, ripple carry

Memory

- ROM Bit-Cells for dynamic and static ROM
- Dynamic ROM module, complete 8 Bit example
 - Clock Module for 8 Bit dynamic ROM
 - Bus Driver for 8 Bit dynamic ROM, with select
 - Bus Driver for 8 Bit dynamic ROM
 - ROM module, 8 Bit example
- Static ROM module, complete 8 Bit Example

Clock Generators, Counters

- 2-Phase clock generator
- Counter, 4 Bit, synchronous

Multiplexers

- 2 Bit Multiplexer
- 2 Bit Multiplexe, alternative
- 4 Bit Multiplexer
- 8 Bit Multiplexer
- 16 Bit Multiplexer

Decoders

- 2 to 4 Bit decoder
- 4 to 16 Bit decoder

Design Rules

KEY :

```
RULE# LAYER_TYPE >= AMOUNT
OR
RULE# LAYER1_TYPE_LAYER2 >= AMOUNT
WHERE TYPE W = WIDTH, S = SPACE, O = OVERLAP
'WELL' = PWELL or NWELL
'DIFF' = PDIFF or NDIFF
'C' = NDC, PDC, NSC, PSC
'GC' = GENERIC CONTACT
'SEL' = NS or PS
'FI' = NFI or PFI
```

1. WELL

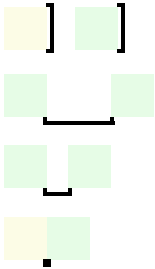

- #1.1 WELL_W >= 12
- #1.2 WELL_S_WELL(AT_DIFF_VOLTAGE) >= 18 [NOT CHECKED]
- #1.3 WELL_S_WELL(AT_SAME_VOLTAGE) >= 6
- #1.4 NWELL_S_PWELL >= 0

2. ACTIVE

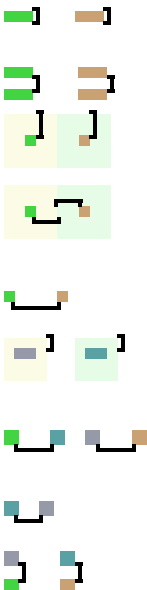

- #2.1 DIFF_W >= 3
- #2.2 DIFF_S >= 3
- #2.3 NWELL_O_PDIFFF >= 6
- #2.3 NWELL_S_NDIFF >= 6
- #2.3 NDIFF_S_PDIFFF >= 12
- #2.4 NWELL_O_NSD >= 3
- #2.5 NDIFF_S_NSD >= 9
- #2.5 NSD_S_PSD >= 6
- #2.5 NDIFF_S_PSD >= 4

3 . POLY



#3.1 POLY_W >= 2



#3.2 POLY_S >= 3



#3.3 POLY_O_DIFF >= 2



#3.4 DIFF_O_POLY >= 3



#3.5 POLY_S_DIFF >= 1

4 . SELECT



#4.1 SEL_S_GATE >= 3



#4.1 OHMIC_S_GATE >= 3



#4.2 SEL_O_ACT >= 2



#4.4 SEL_W >= 2



#4.4 SEL_S >= 2

5 . POLY CONTACT



#5.1 PC_W >= 4



#5.2 POLY_O_GC >= 1



#5.5.b PC_S_POLY >= 4

6 . DIFF CONTACT



#6.1 C_W >= 4



#6.2 ACT_O_GC >= 1



#6.3 GC_S >= 3



#6.4 C_S_GATE >= 1



#6.5.b PC_S_ACT >= 1



#6.5.b DIFF_S_C >= 4



#6.8 POLY_S_MULT_DIFF >= 2 [NOT CHECKED]

7. METAL1



#7.1 M1_W >= 3



#7.2 M1_S >= 3



#7.3 M1_Q_GC >= 1

8. VIA1



#8.1 M2C_W >= 4



#8.1 GV1_W >= 2



#8.2 GV1_S >= 3



#8.3 M1_Q_GV1 >= 1

9. METAL2



#9.1 M2_W >= 3



#9.2 M2_S >= 3



#9.3 M2_Q_GV1 >= 1

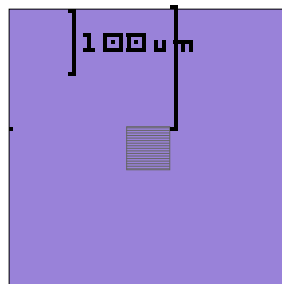

10. PAD

#10.1 PAD_W >= 100um [NOT CHECKED]

#10.2 PAD_Q_G >= 30



#10.3 M4_Q_G >= 6um [NOT CHECKED]

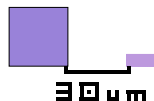

#10.4 PAD_S_M2-M4 >= 30um [NOT CHECKED]

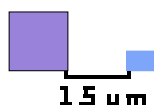

#10.5 PAD_S_M1 >= 15um [NOT CHECKED]

14. VIA2



#14.1 M3C_W >= 4



#14.1 GV2_W >= 2



#14.2 GV2_S >= 3

15. METAL3



#15.1 M3_W >= 3



#15.2 M3_S >= 3

21. VIA3



#21.1 M4C_W >= 4



#21.1 GV3_W >= 2



#21.2 GV3_S >= 4

22. METAL4



#22.1 M4_W >= 6



#22.2 M4_S >= 6



#22.3 M4_D_M4C >= 1



#22.3 M4_D_GV3 >= 2

29. FIELD IMPLANT



#29.1 FI_W >= 4



#29.2 FI_S >= 4



#29.3 WELL_D_FI >= 4



#29.4 WELL_S_FI >= 4

Cell Library

1

2

3

4

D

D

inv_35

C

C

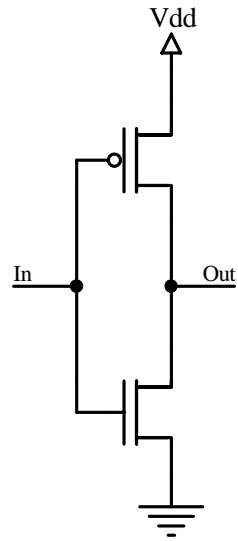

B

B

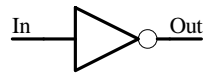

A

A

1

2

3

4

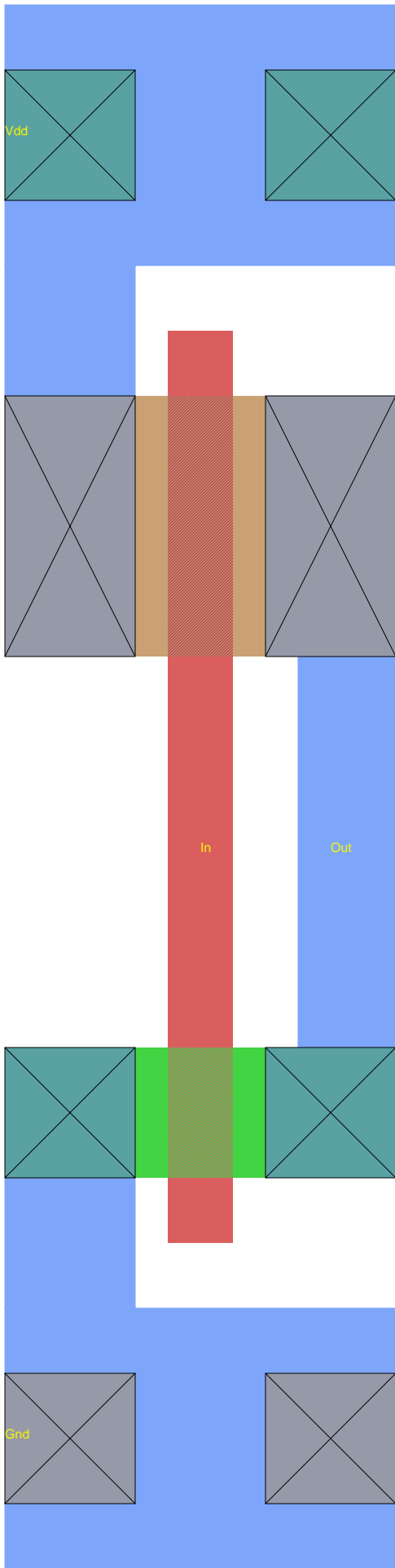

* hspice file created from inv_35.ext - technology: s

| Wave | Symbol |
|--------------|--------|
| D0:A0:v(out) | X |
| D0:A0:v(in) | O |

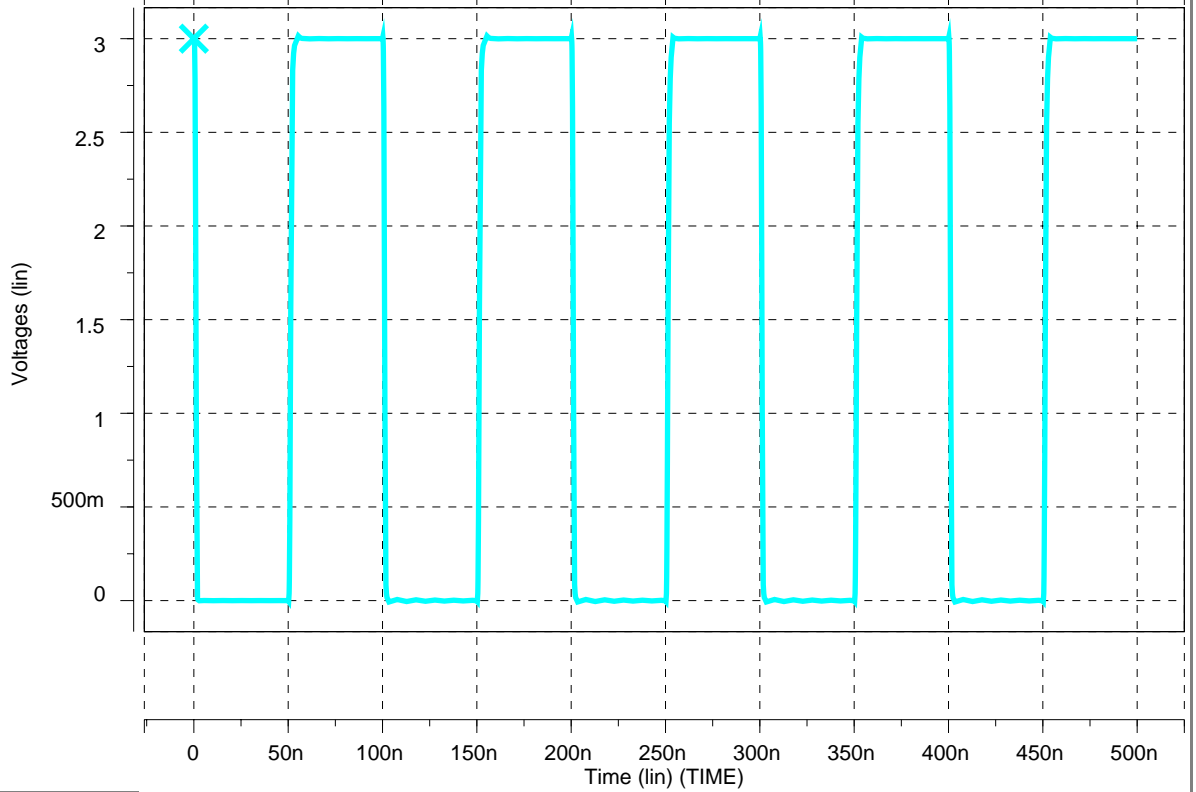
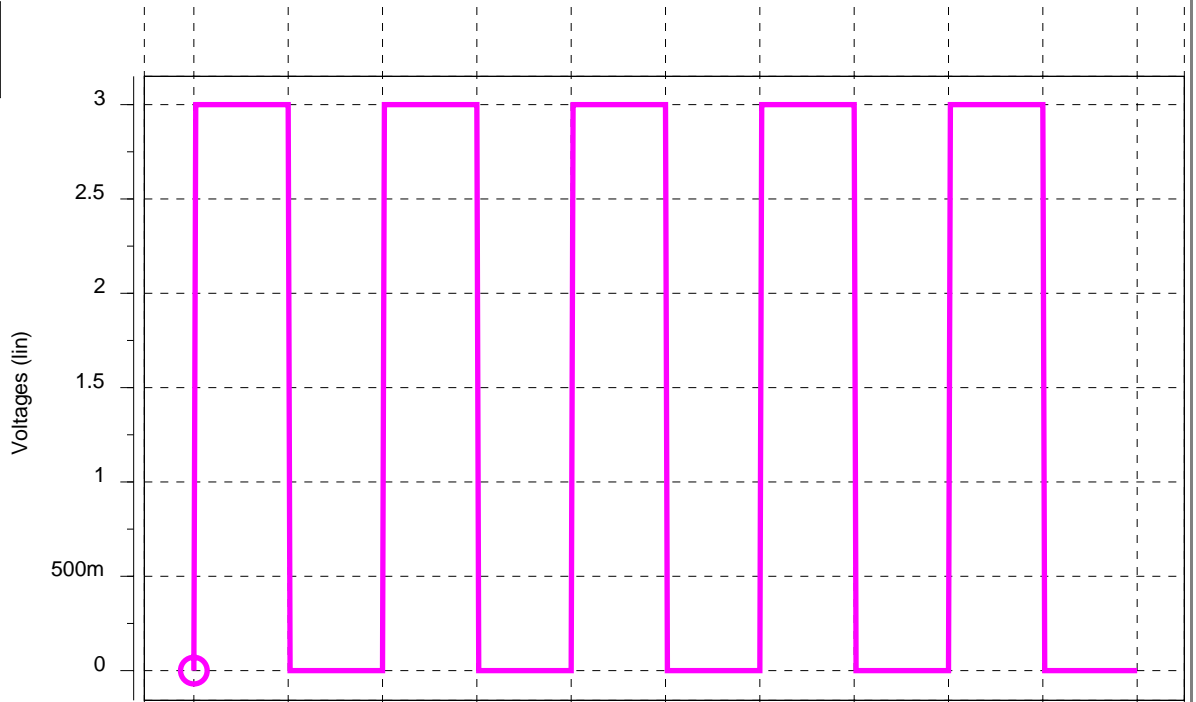

delayinv3x9_35

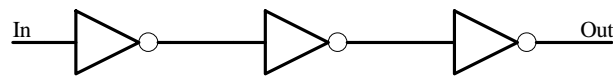
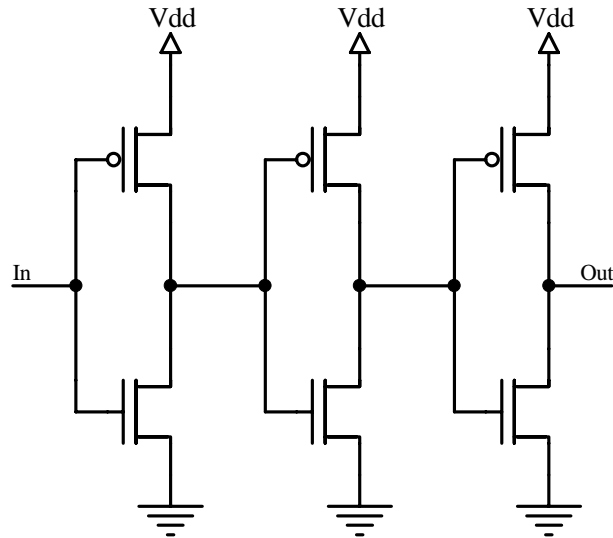

| W/L: | |
|------------|------|
| n-channel: | 4:18 |
| p-channel: | 8:18 |

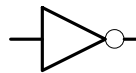

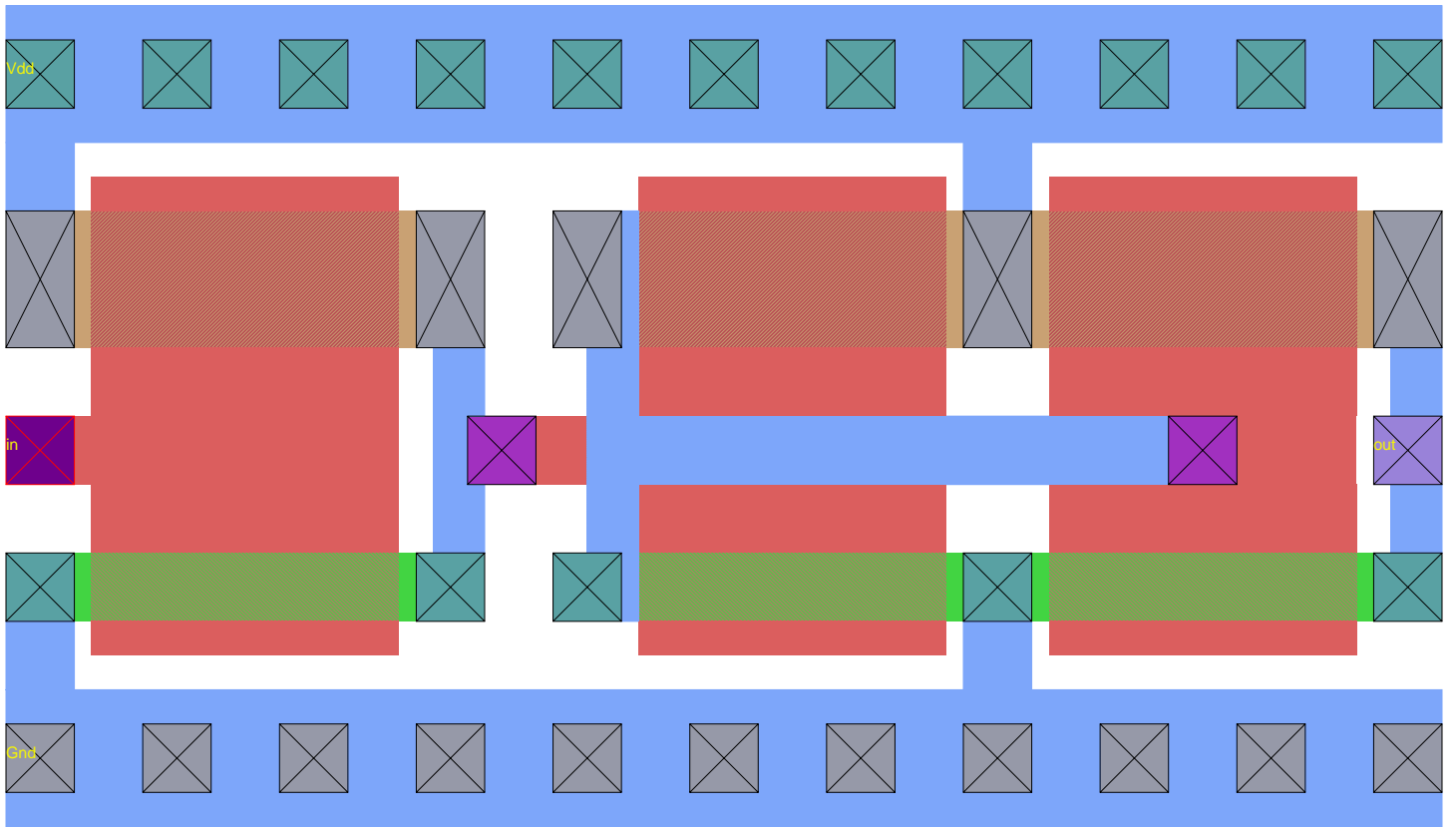

bufferx3_35

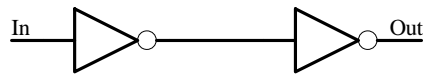
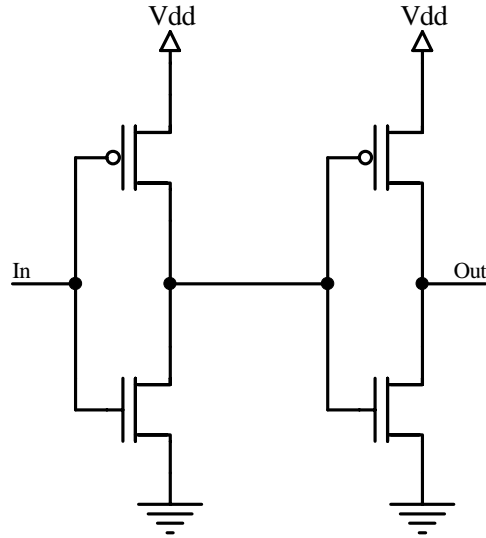

| | | | |
|------------|------|---|------|
| W/L: | 3 | : | 9 |
| n-channel: | 12:2 | | 36:2 |
| p-channel: | 24:2 | | 72:2 |

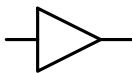

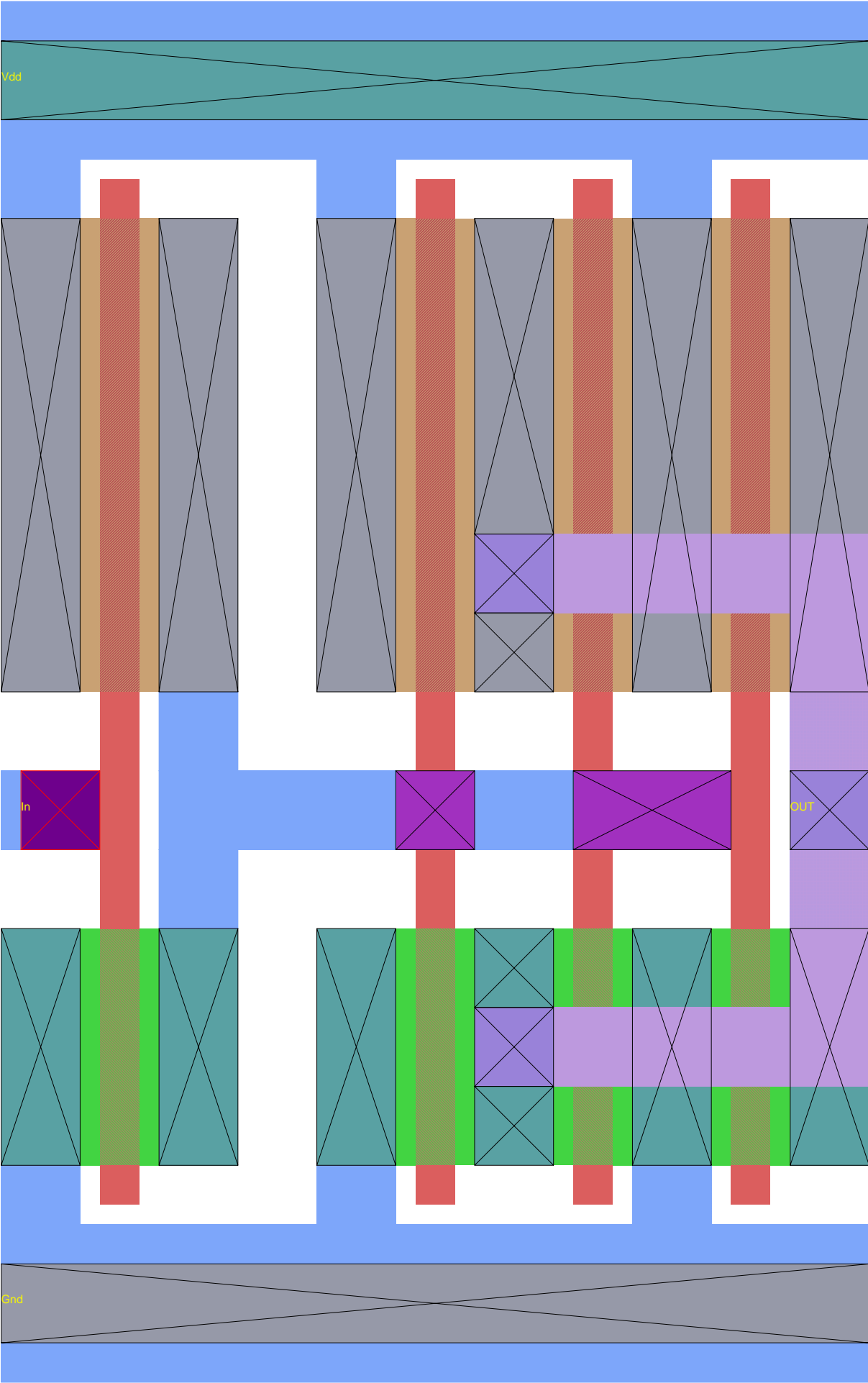

bufferx4_35

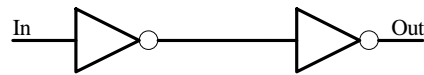
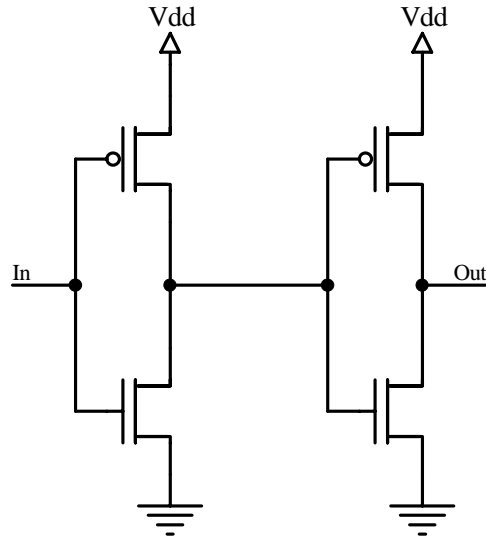

| | | | |
|------------|------|---|-------|
| W/L: | 4 | : | 16 |
| n-channel: | 16:2 | | 64:2 |
| p-channel: | 32:2 | | 128:2 |

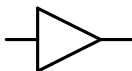

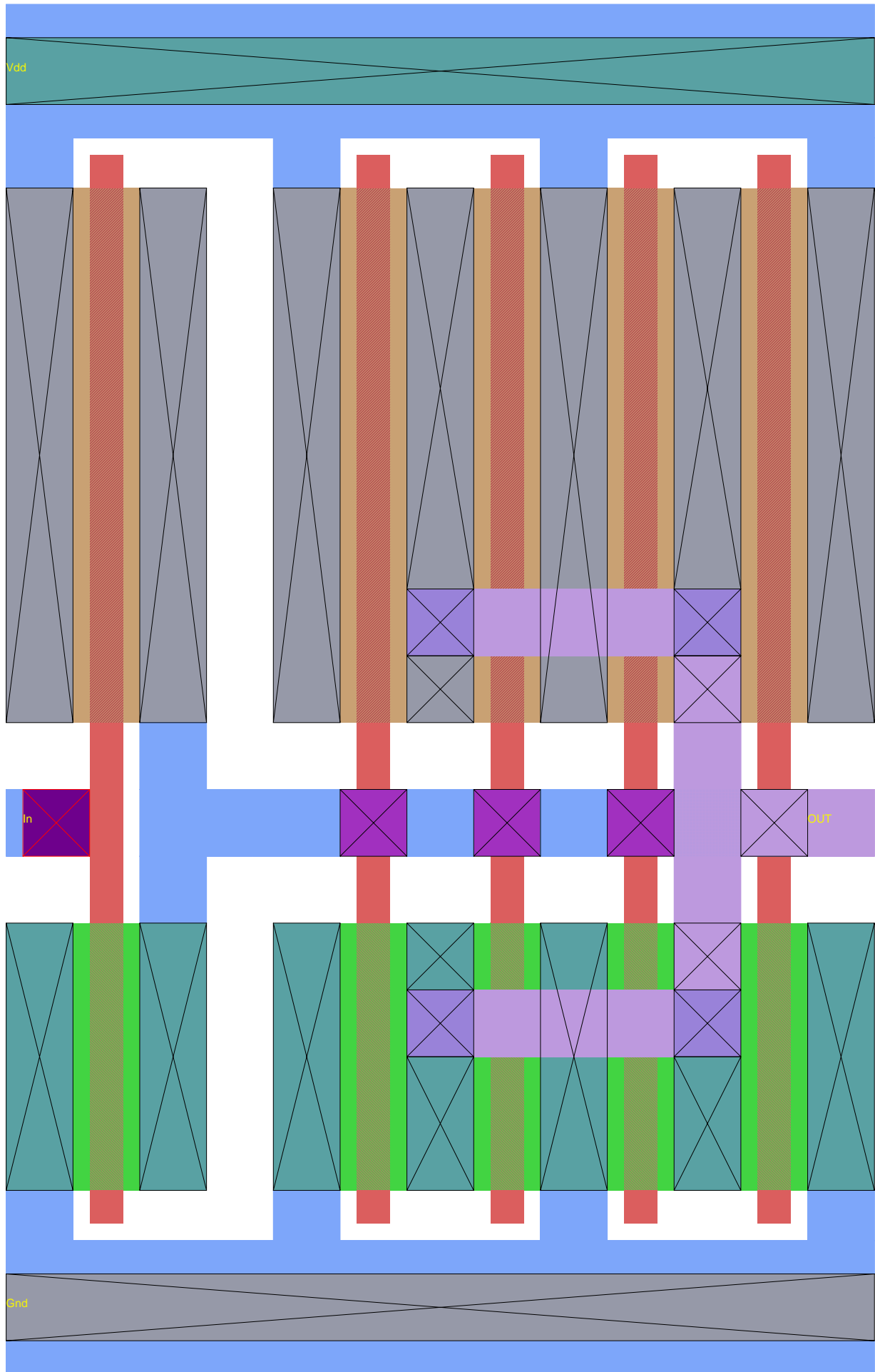

bufferx6_35

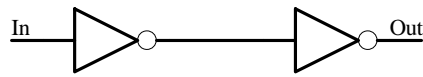
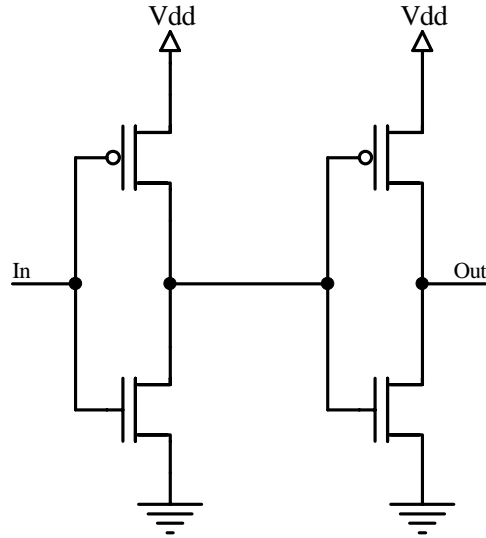

| | | | |
|------------|------|---|-------|
| W/L: | 6 | : | 36 |
| n-channel: | 24:2 | | 144:2 |
| p-channel: | 48:2 | | 288:2 |

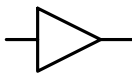

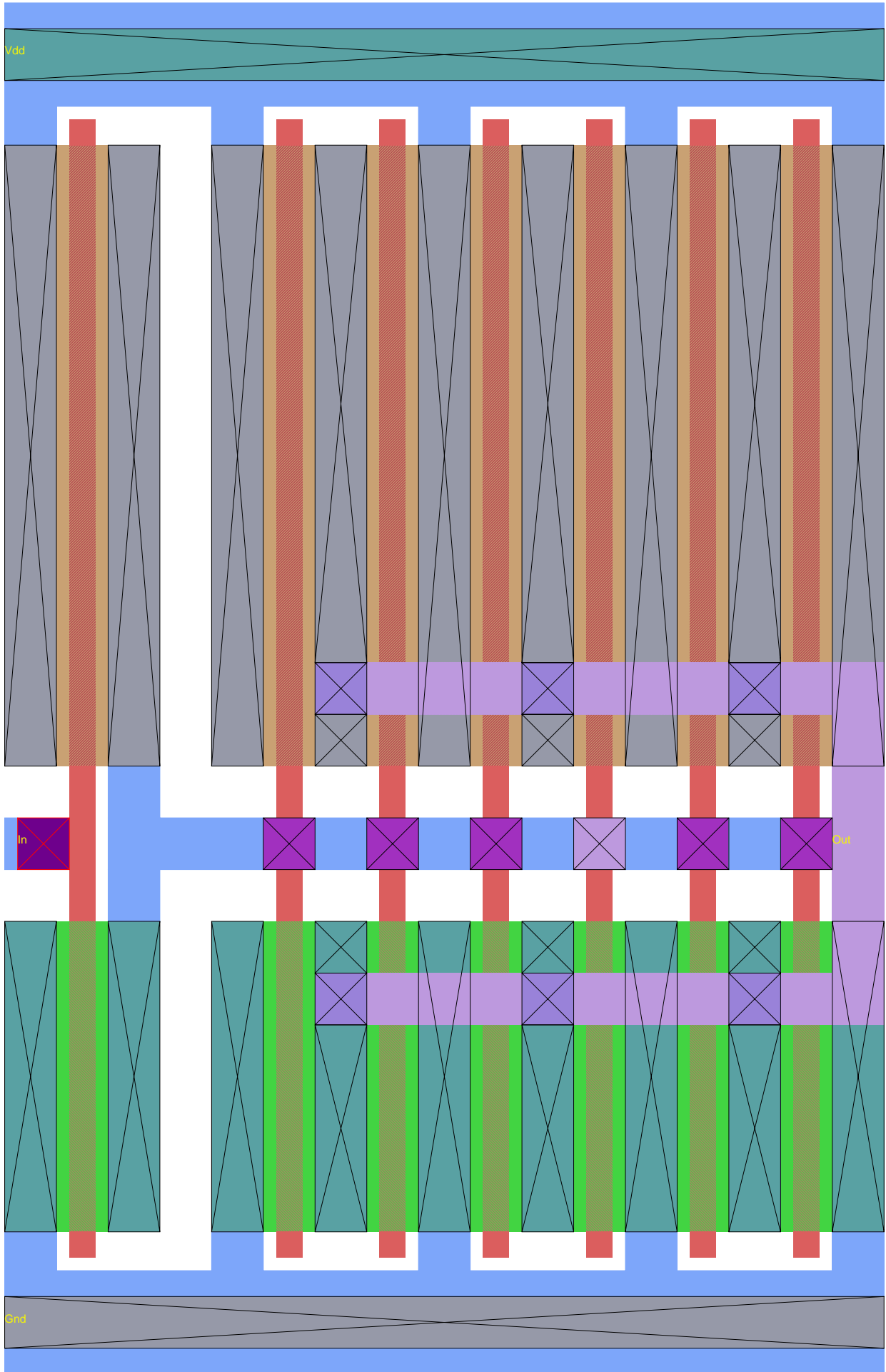

bufferx8_35

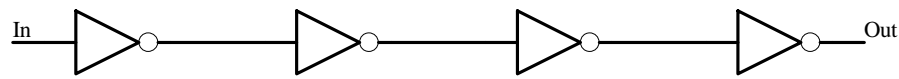
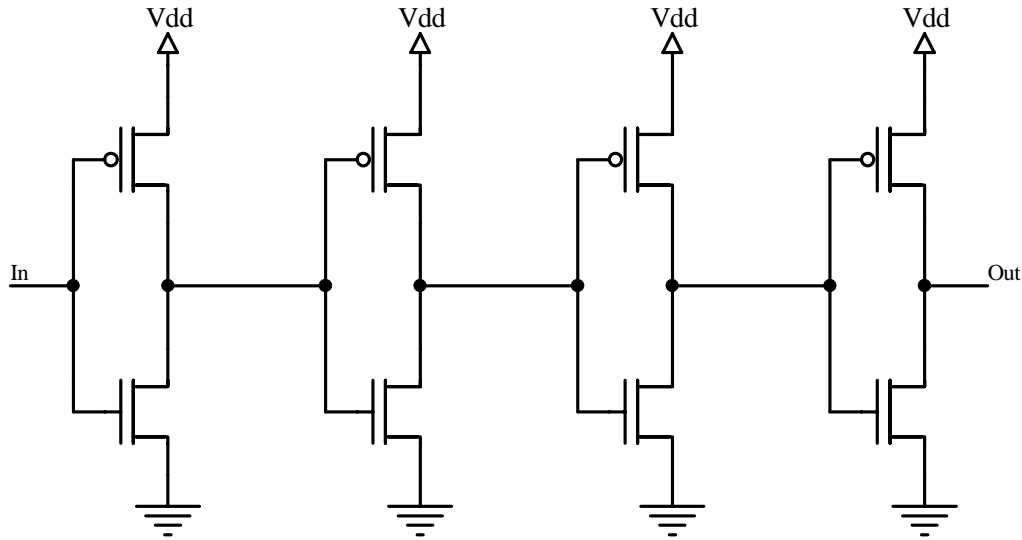

| | | | | | | | |
|------------|------|---|------|---|-------|---|-------|
| W/L: | 2 | : | 4 | : | 16 | : | 64 |
| n-channel: | 6:2 | | 14:2 | | 60:2 | | 256:2 |
| p-channel: | 16:2 | | 36:2 | | 124:2 | | 512:2 |

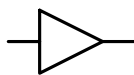

Vdd

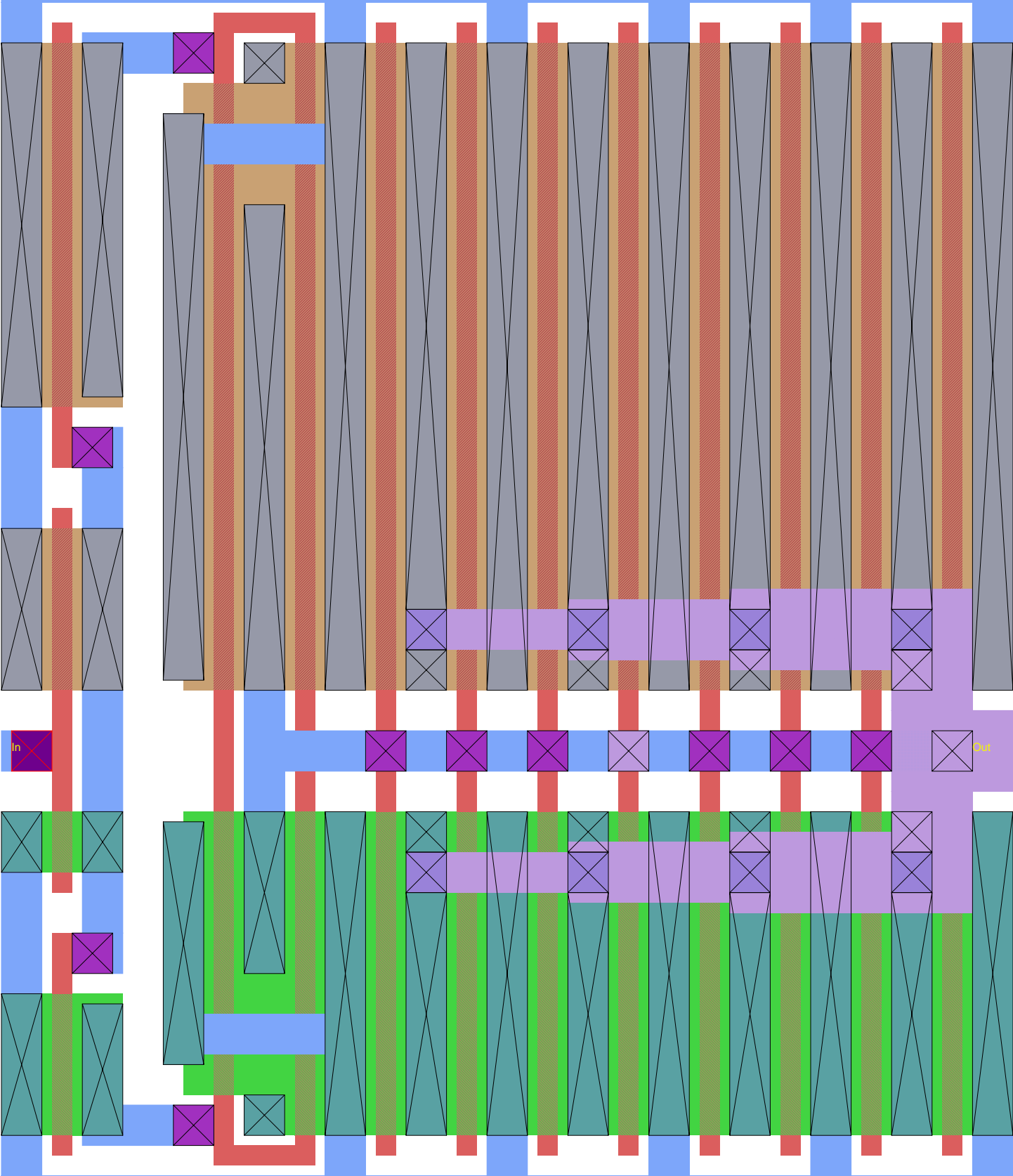

Gnd

bufferx10_35

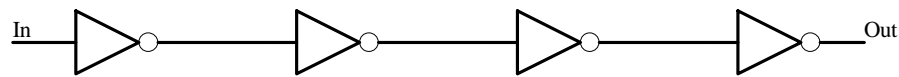
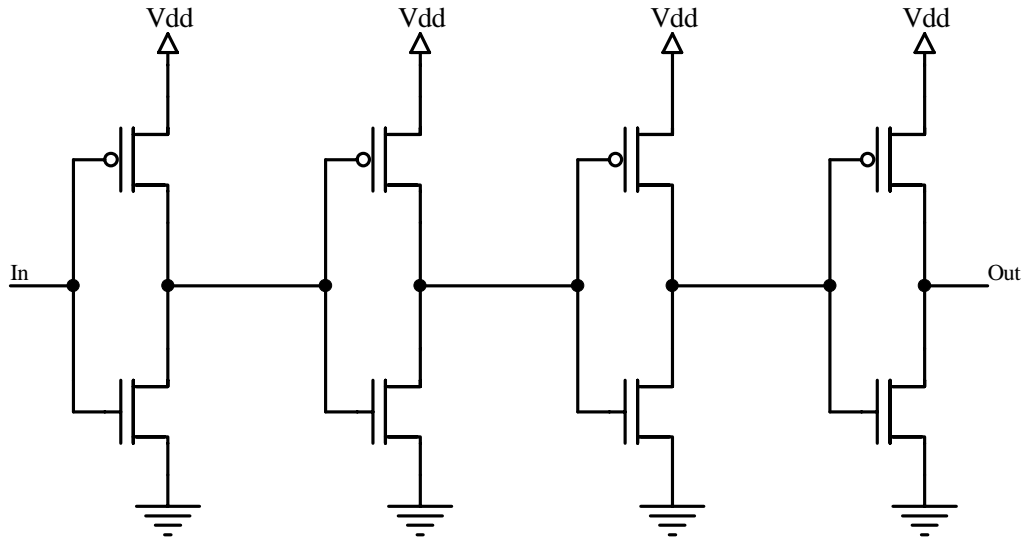

| | | | | | | | |
|------------|------|---|------|---|-------|---|-------|
| W/L: | 2 | : | 5 | : | 20 | : | 100 |
| n-channel: | 8:2 | | 20:2 | | 76:2 | | 400:2 |
| p-channel: | 20:2 | | 48:2 | | 156:2 | | 800:2 |

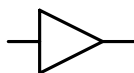

Vdd

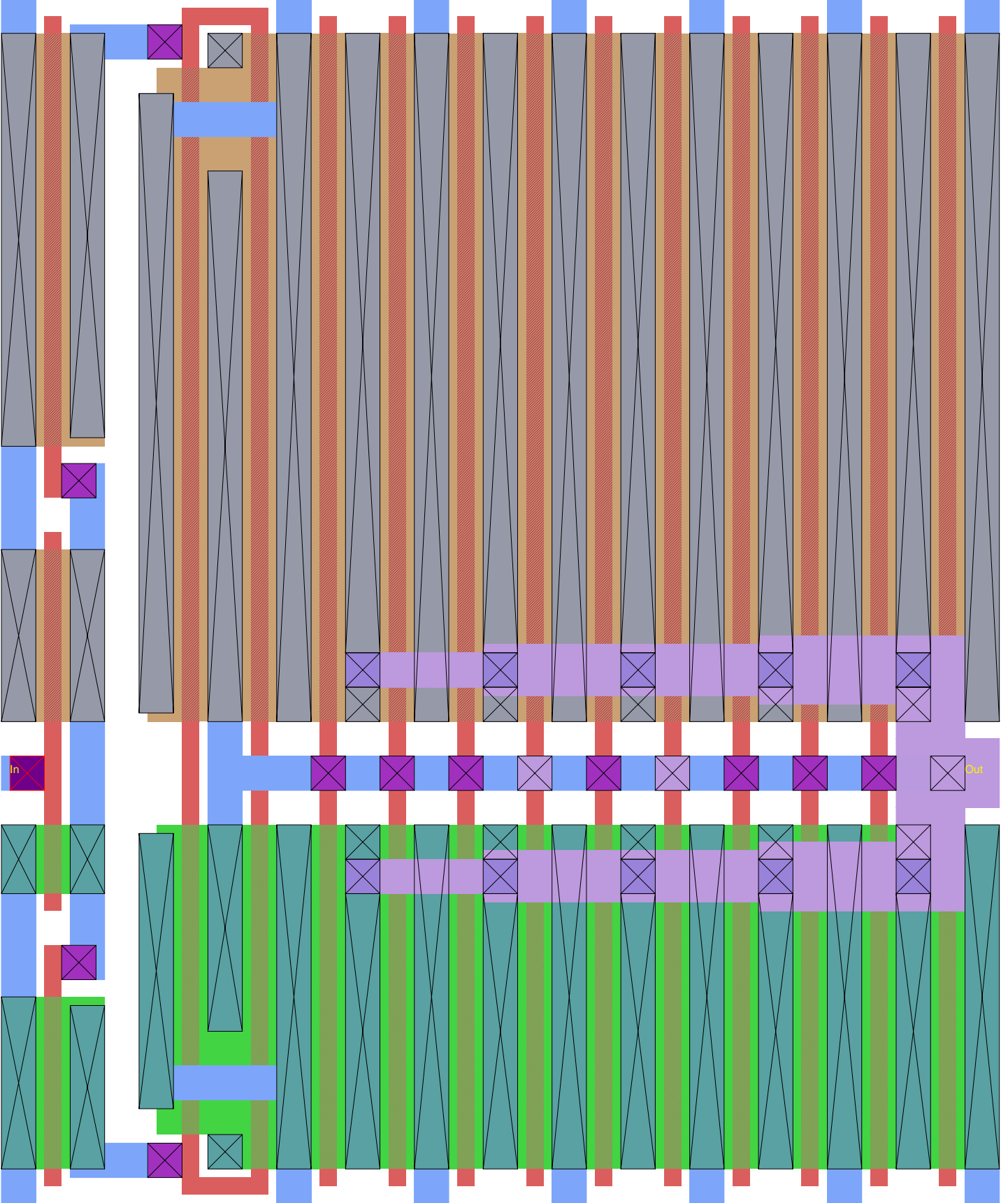

Gnd

bufferx12_35

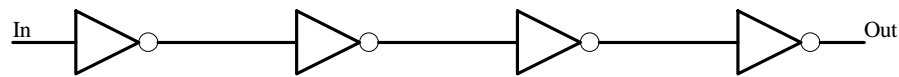
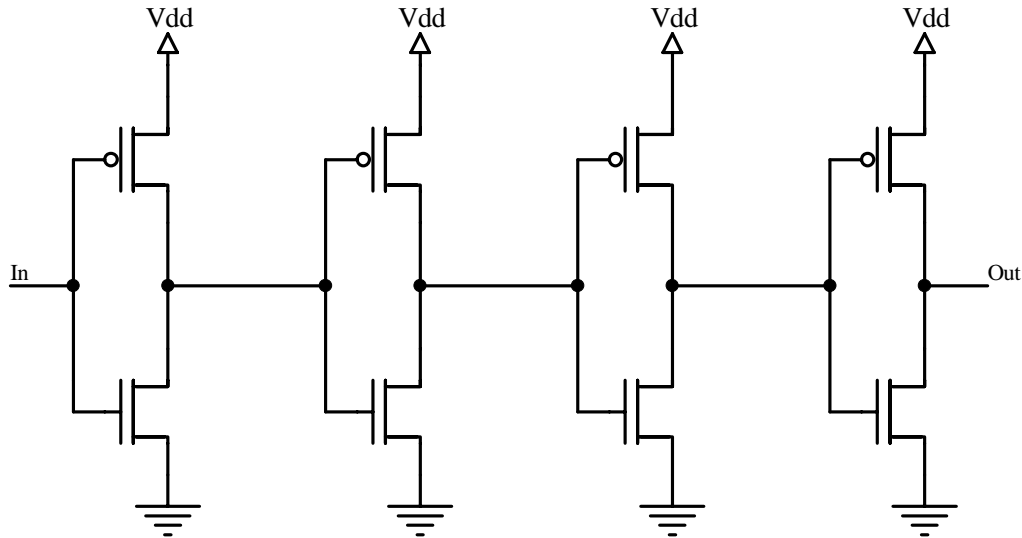

| | | | | | | | |
|------------|------|---|------|---|-------|---|--------|
| W/L: | 2 | : | 8 | : | 36 | : | 144 |
| n-channel: | 8:2 | | 30:2 | | 140:2 | | 576:2 |
| p-channel: | 18:2 | | 67:2 | | 284:2 | | 1152:2 |

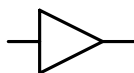

Vdd

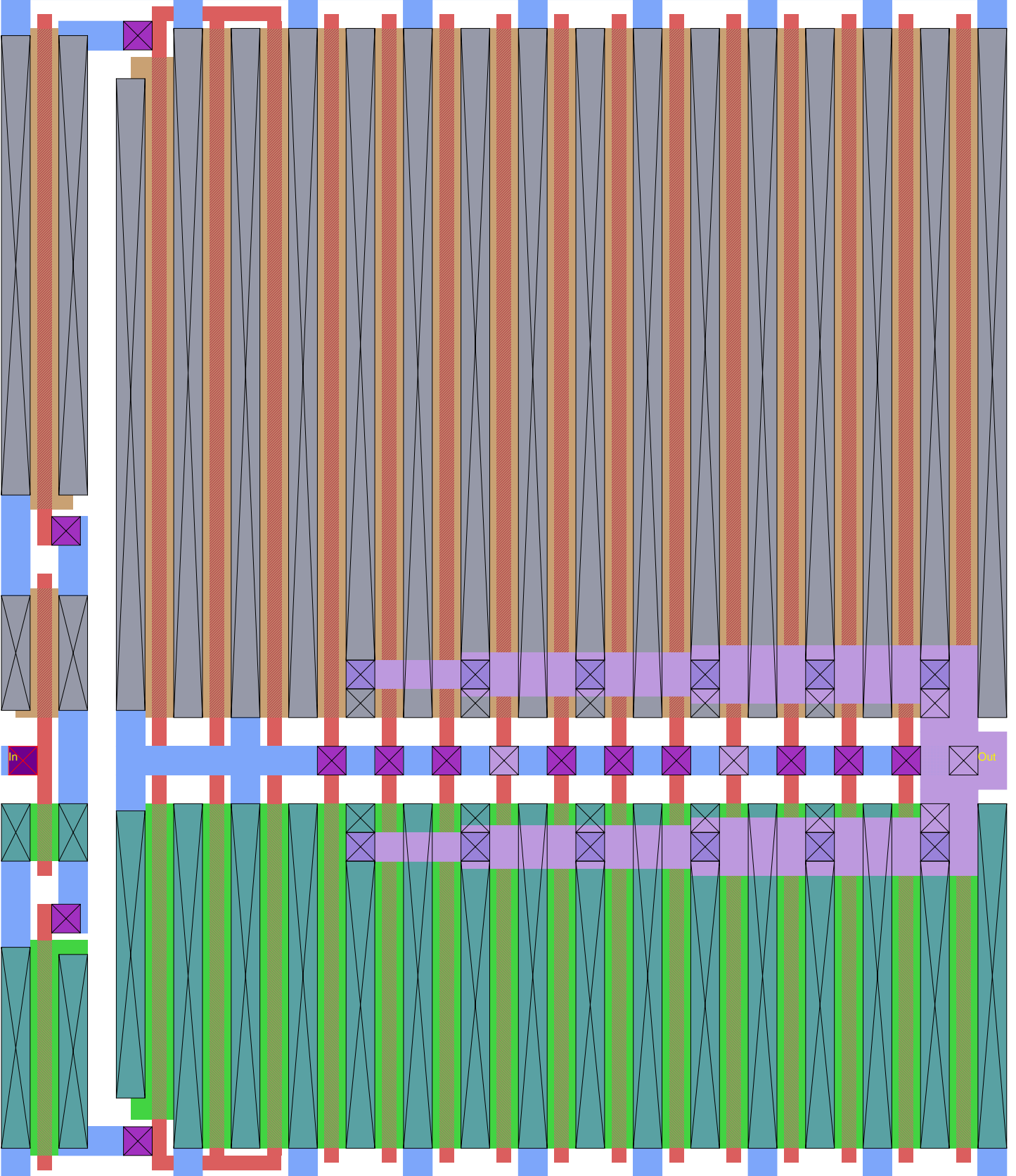

Gnd

1

2

3

4

D

D

nand_35

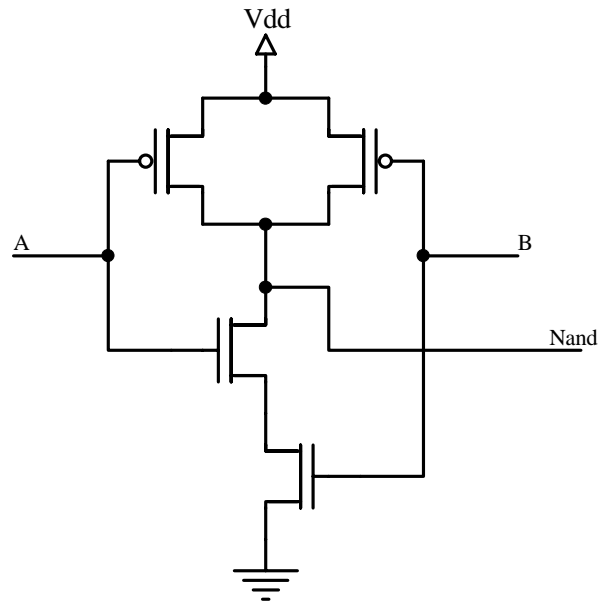

C

C

B

B

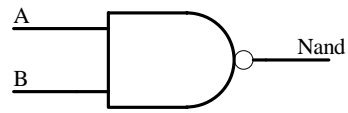

A

A

1

2

3

4

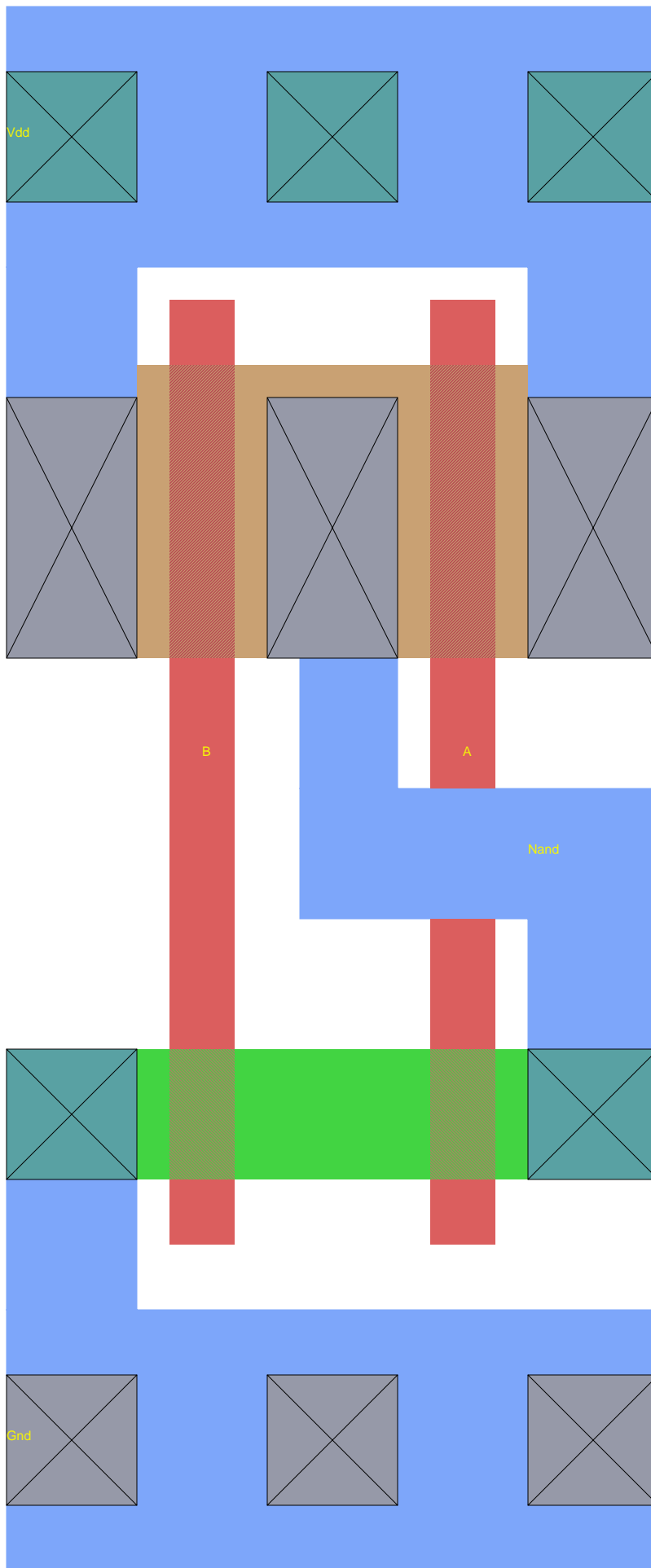

* hspice file created from nand_35.ext - technology:

| Wave | Symbol |
|---------------|--------|
| D0:A0:v(nand) | X |
| D0:A0:v(b) | ○ |
| D0:A0:v(a) | △ |

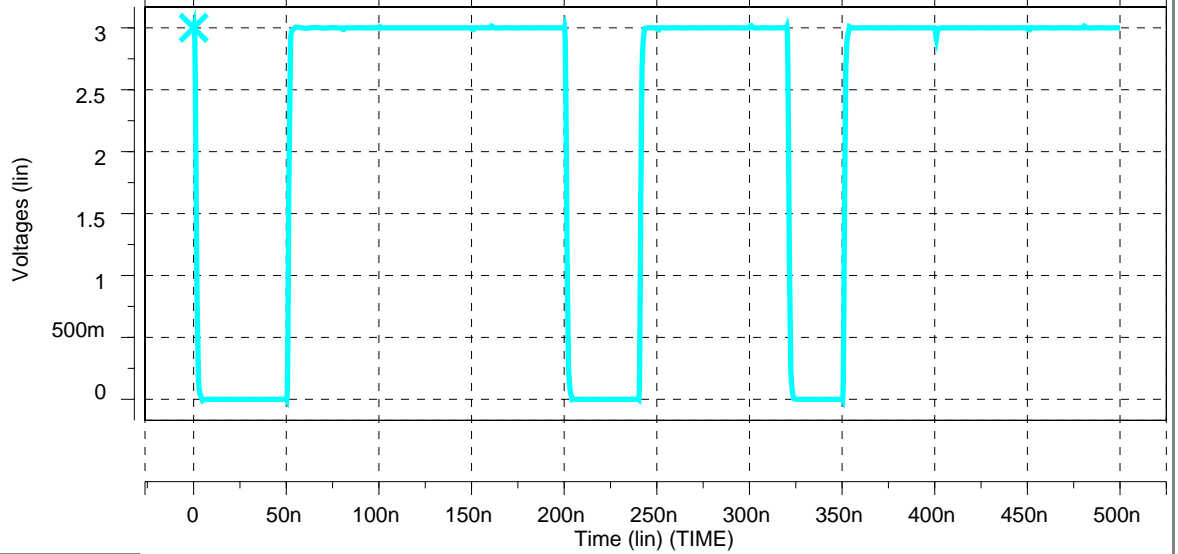
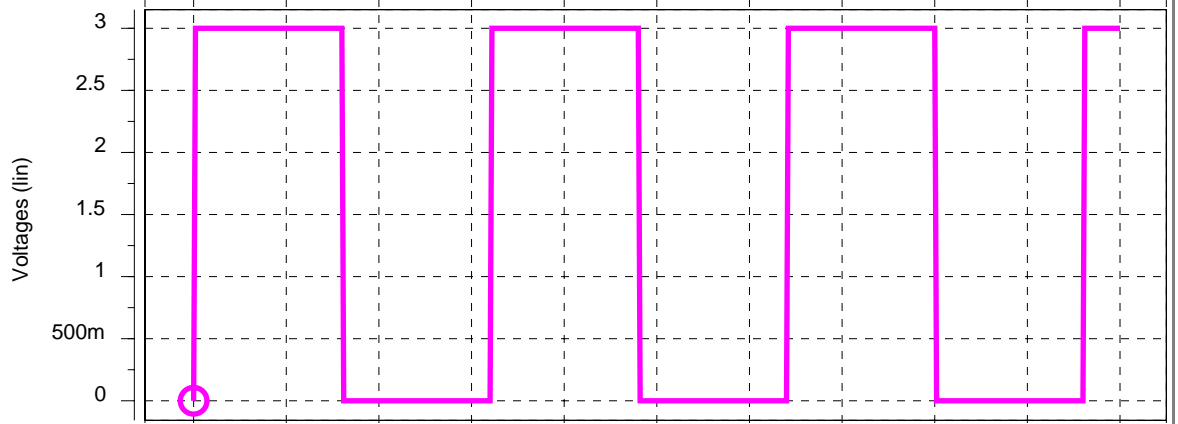
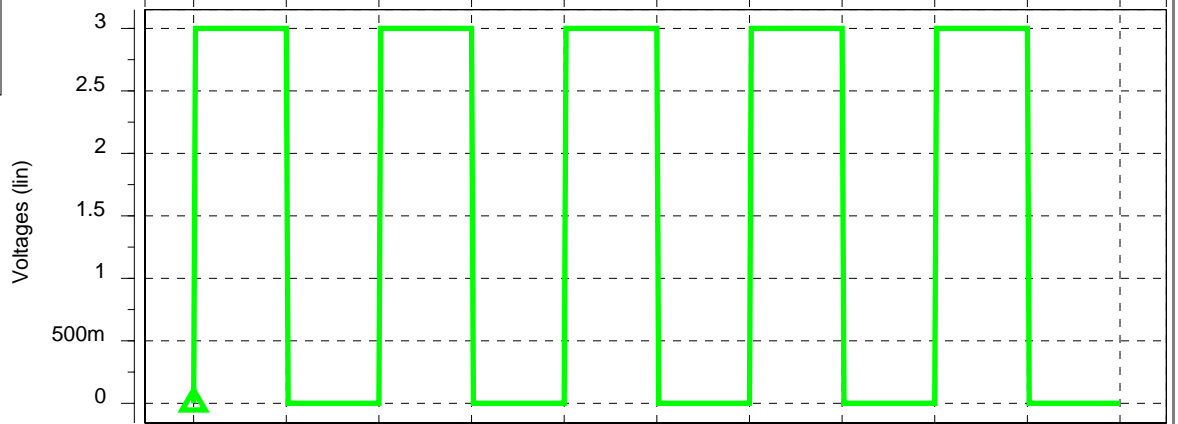

4nand_35

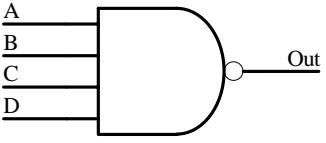
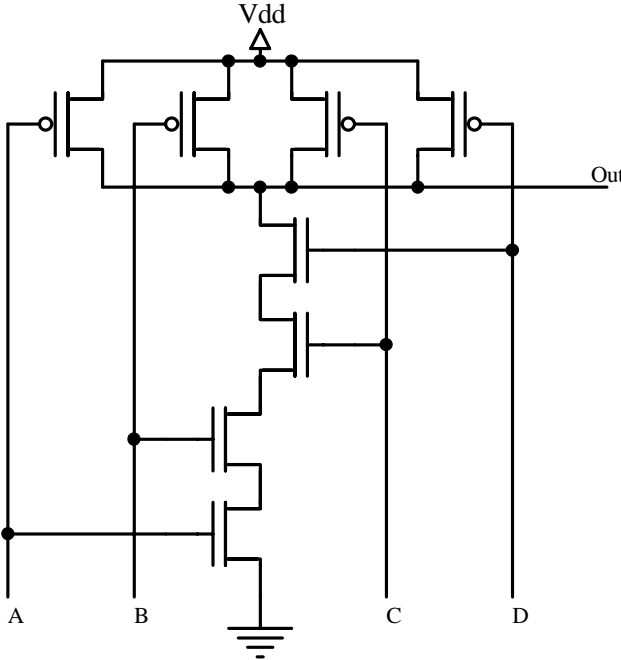

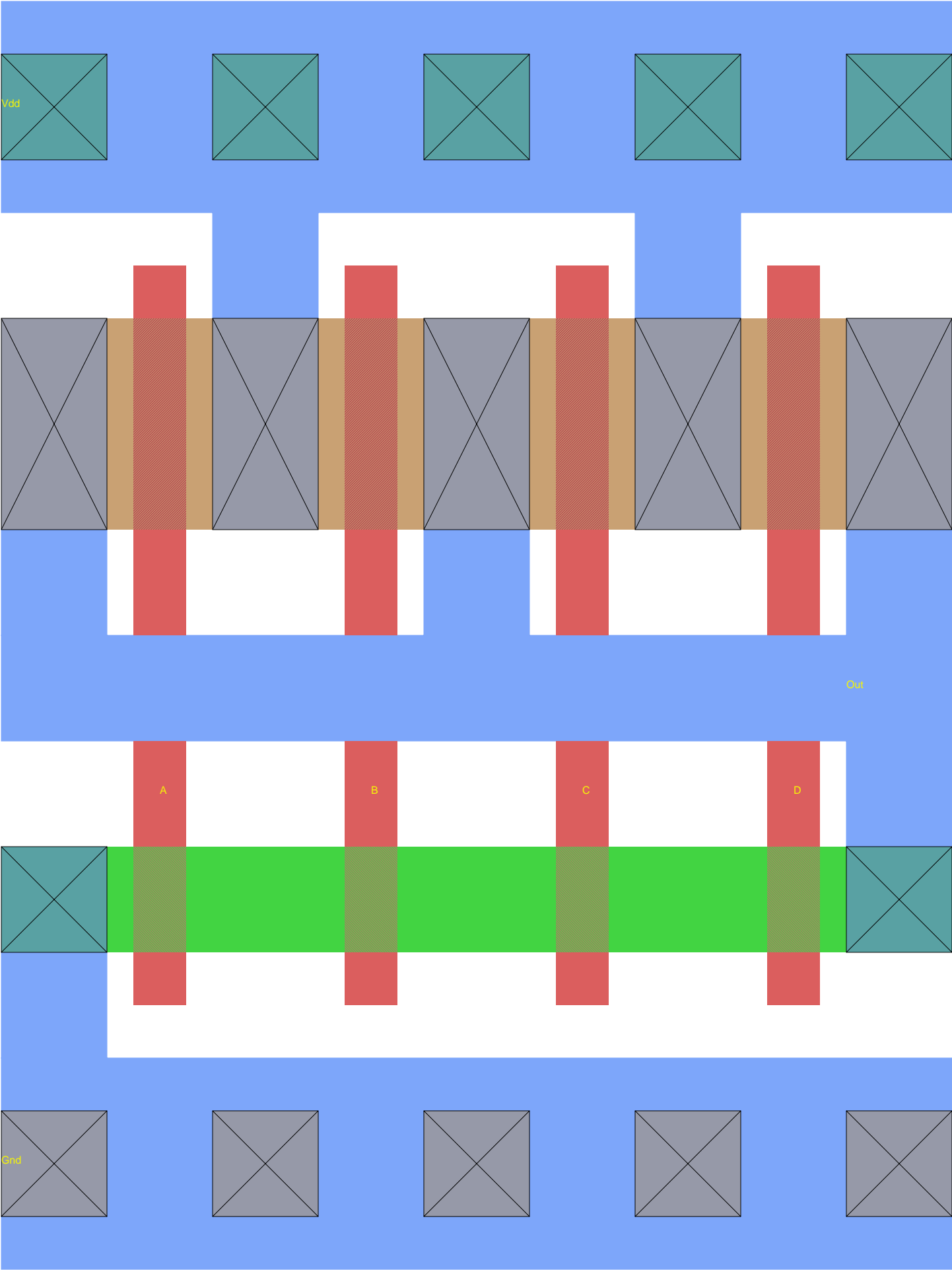

* hspice file created from 4nand_35.ext - technology: scmos

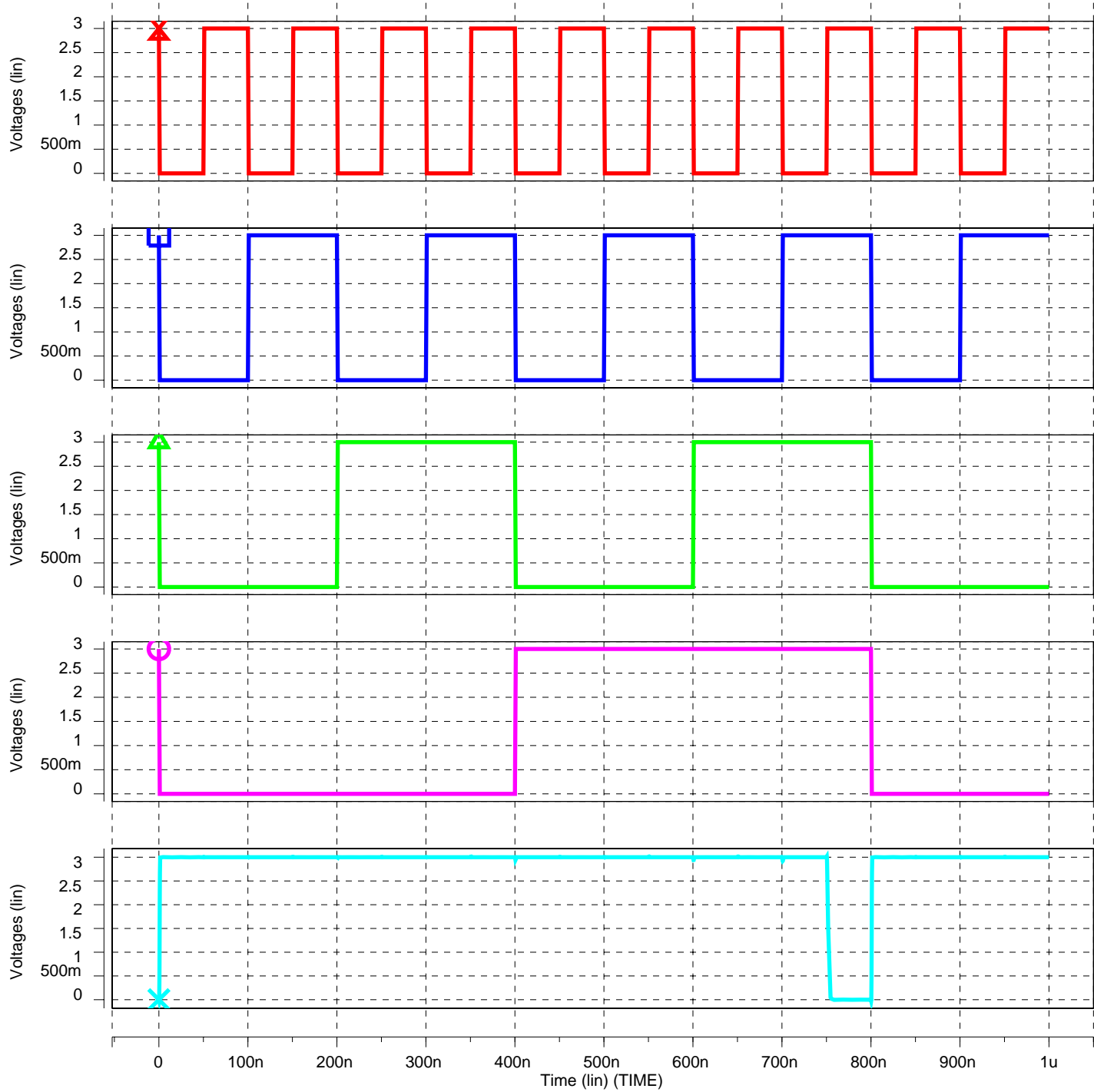

| Design | Type | Wave | Symbol |
|-------------------------------------|-----------|--------------|--------|
| D0: /grads/mr/thesis/magic/4nand_35 | Transient | D0:A0:v(out) | ⊗ |
| D0: /grads/mr/thesis/magic/4nand_35 | Transient | D0:A0:v(d) | ⊙ |
| D0: /grads/mr/thesis/magic/4nand_35 | Transient | D0:A0:v(c) | △ |
| D0: /grads/mr/thesis/magic/4nand_35 | Transient | D0:A0:v(b) | ⊠ |
| D0: /grads/mr/thesis/magic/4nand_35 | Transient | D0:A0:v(a) | ⊗ |

1

2

3

4

D

D

and_35

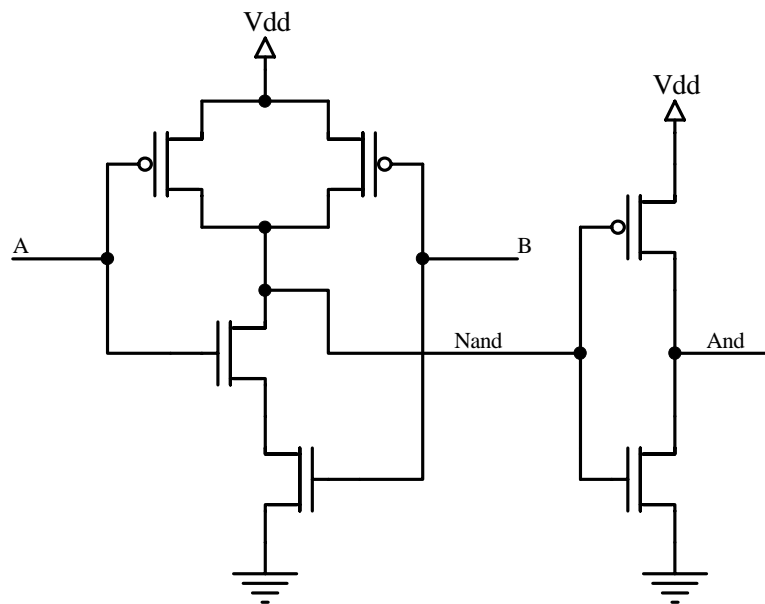

C

C

B

B

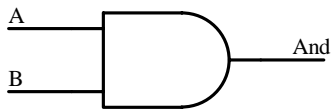

A

A

1

2

3

4

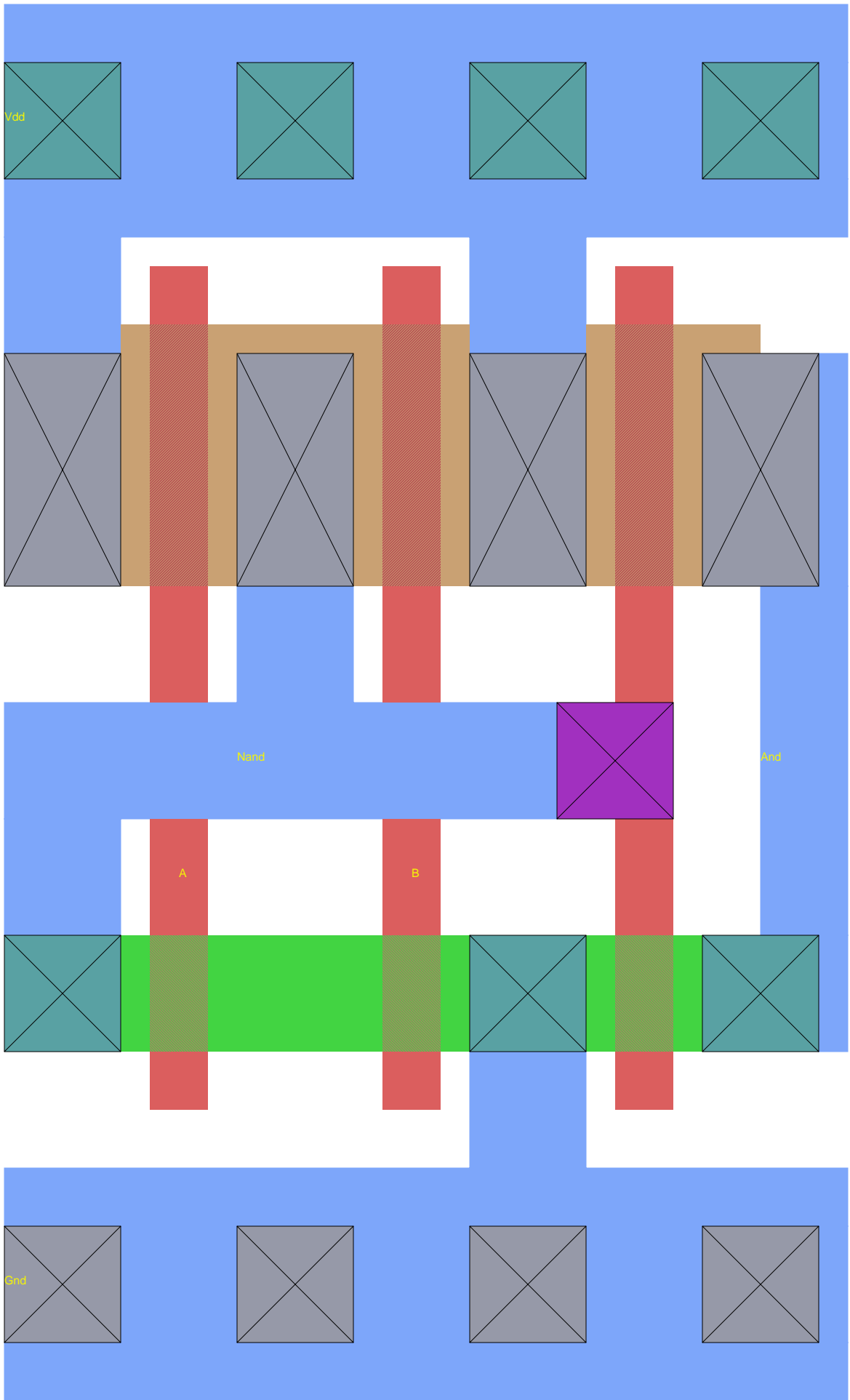

* hspice file created from and_35.ext - technology: s

| Wave | Symbol |
|--------------|--------|
| D0:A0:v(and) | X |
| D0:A0:v(b) | O |
| D0:A0:v(a) | △ |

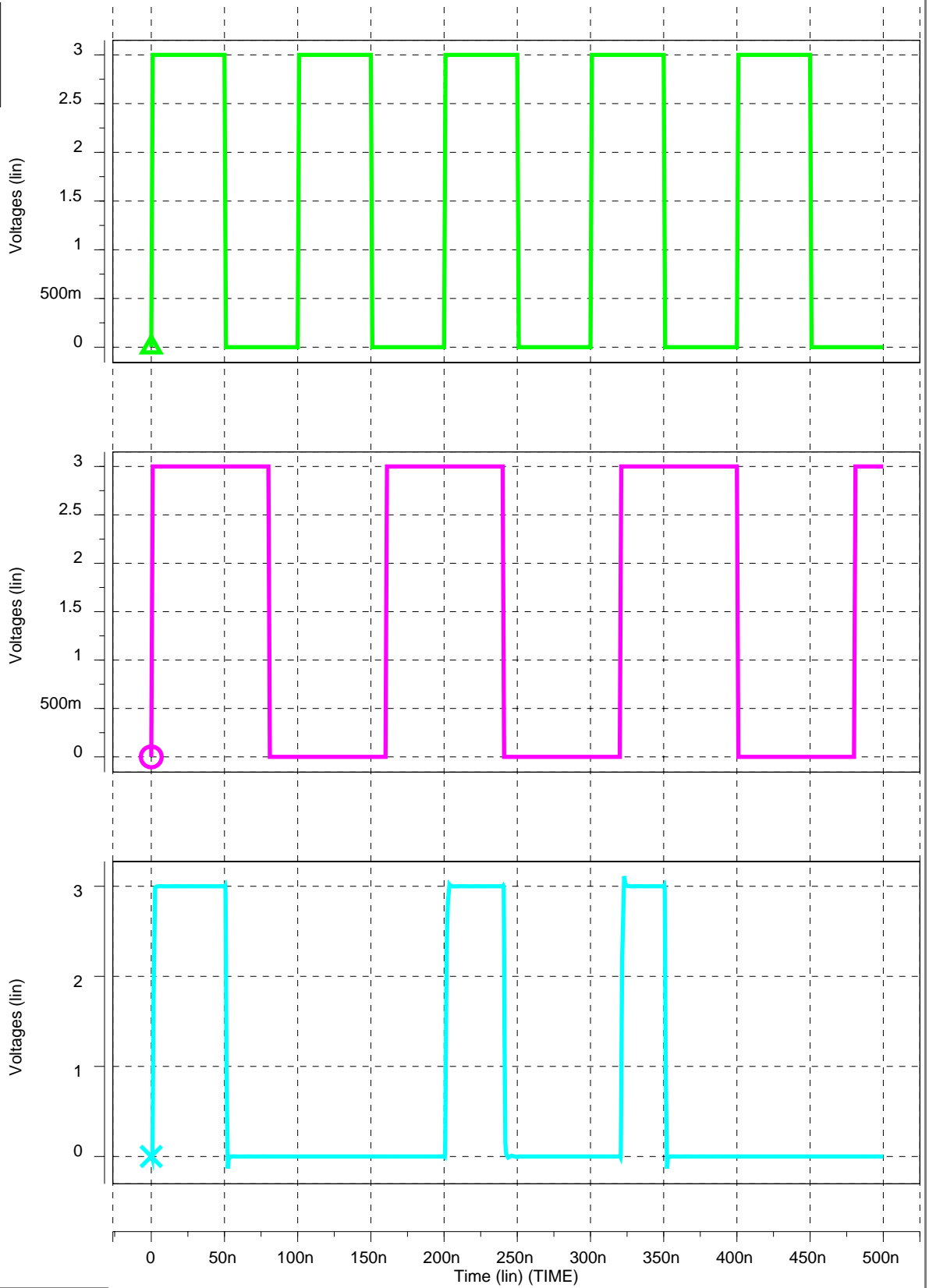

nor_35

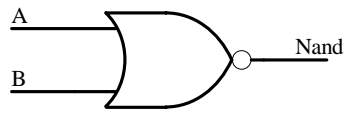
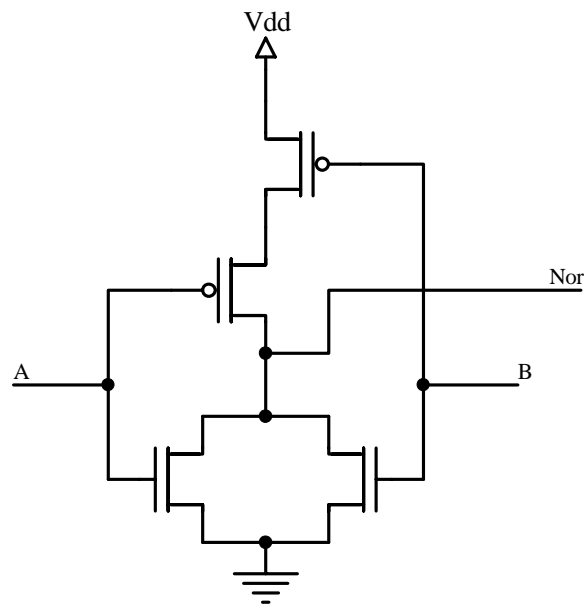

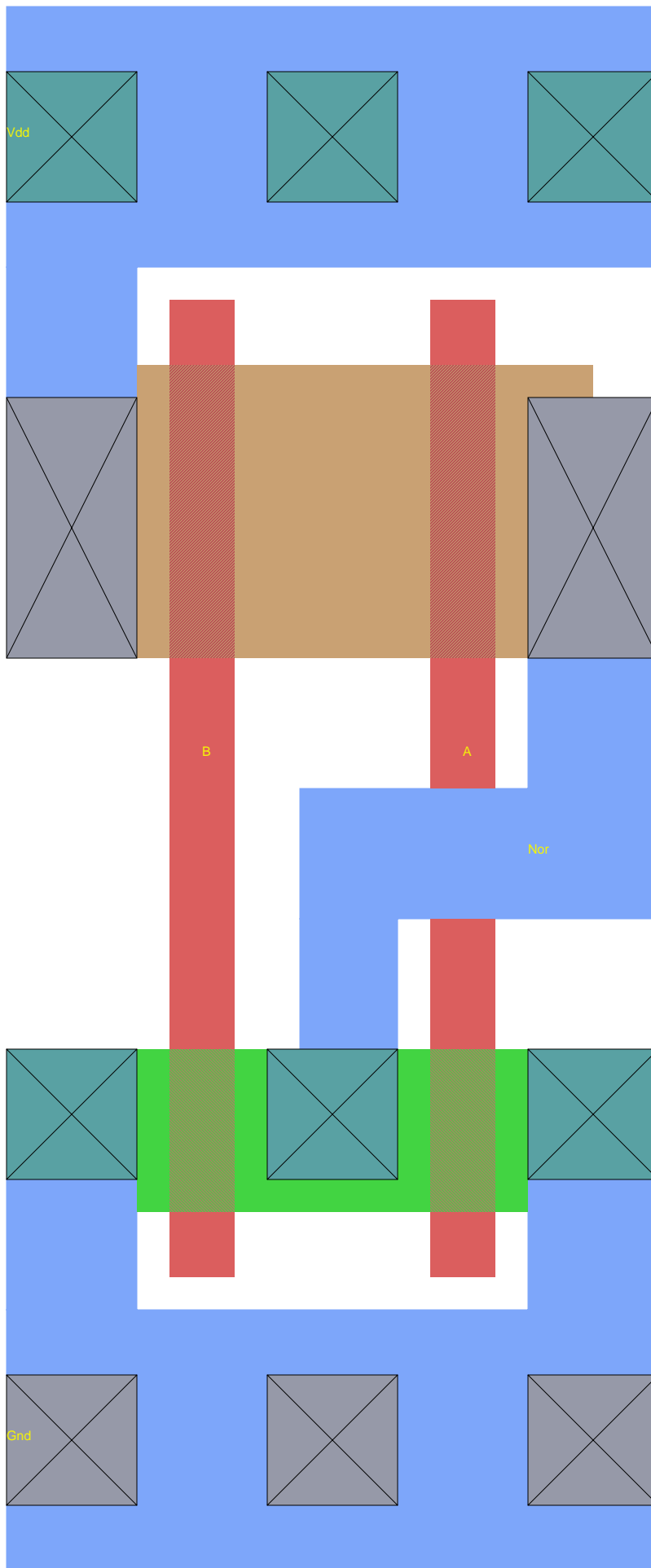

* hspice file created from nor_35.ext - technology: s

| Wave | Symbol |
|--------------|--------|
| D0:A0:v(nor) | X |
| D0:A0:v(b) | O |
| D0:A0:v(a) | △ |

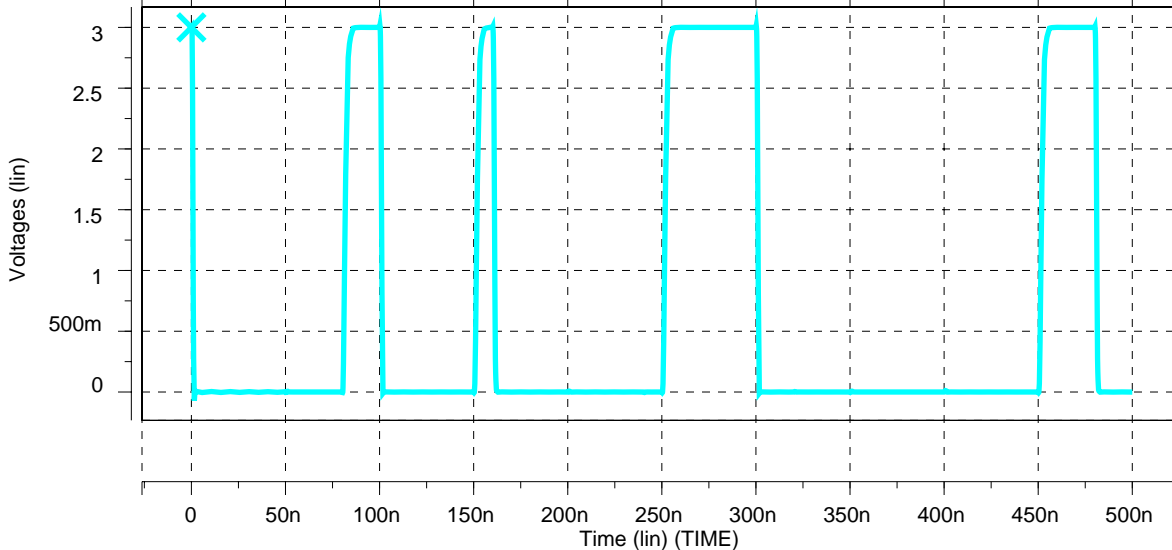
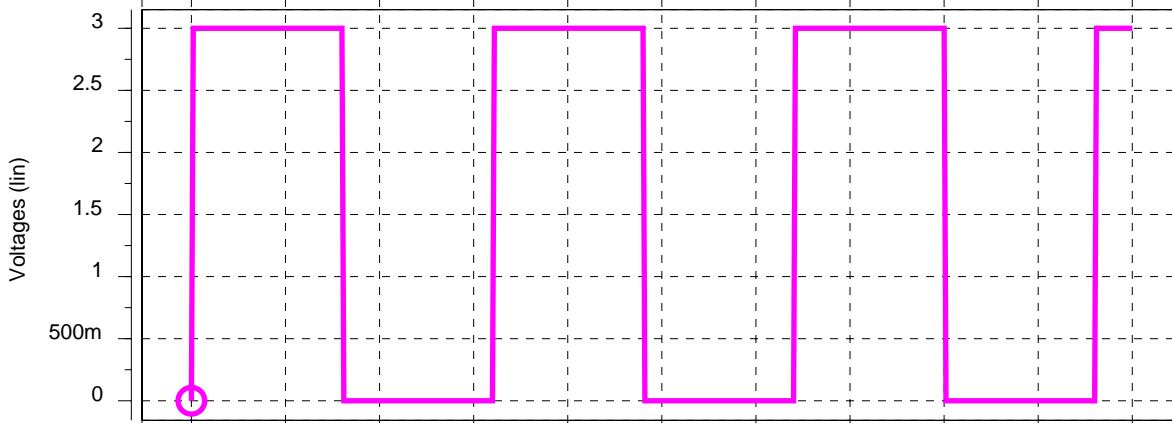
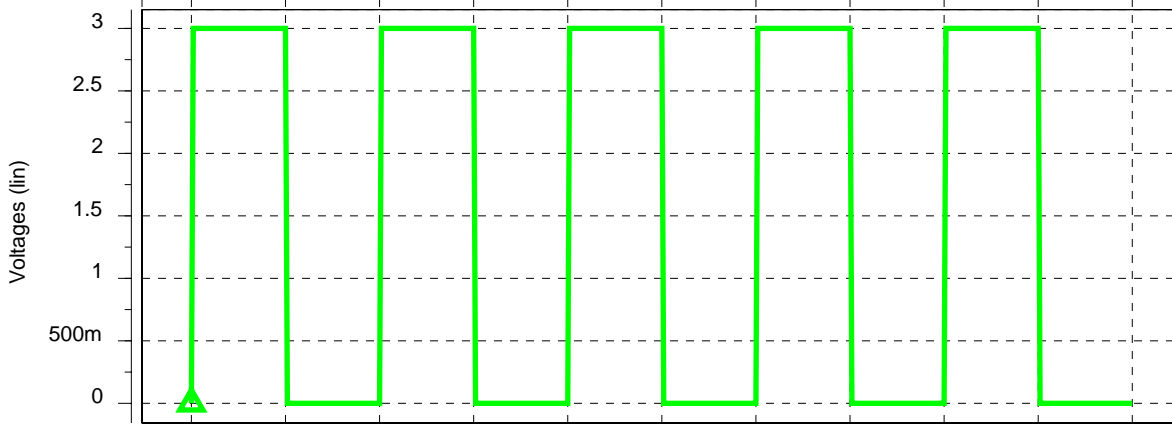

1

2

3

4

D

D

or_35

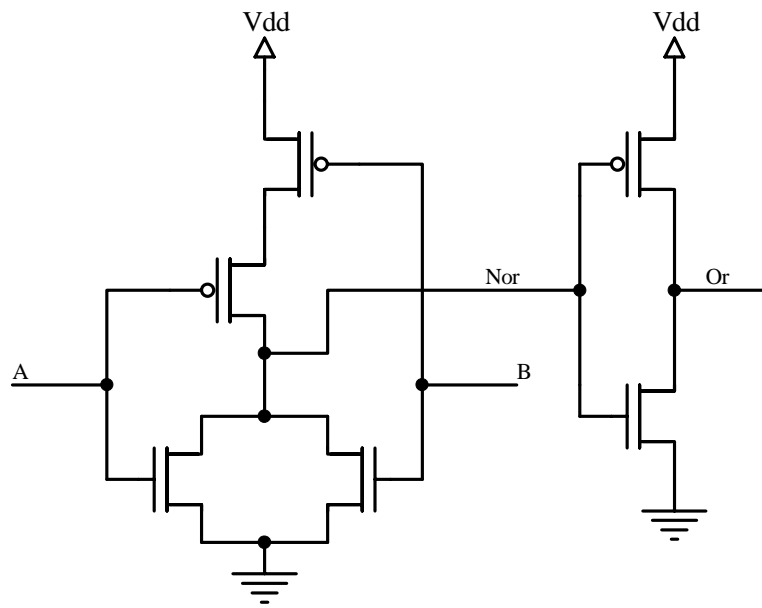

C

C

B

B

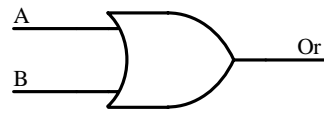

A

A

1

2

3

4

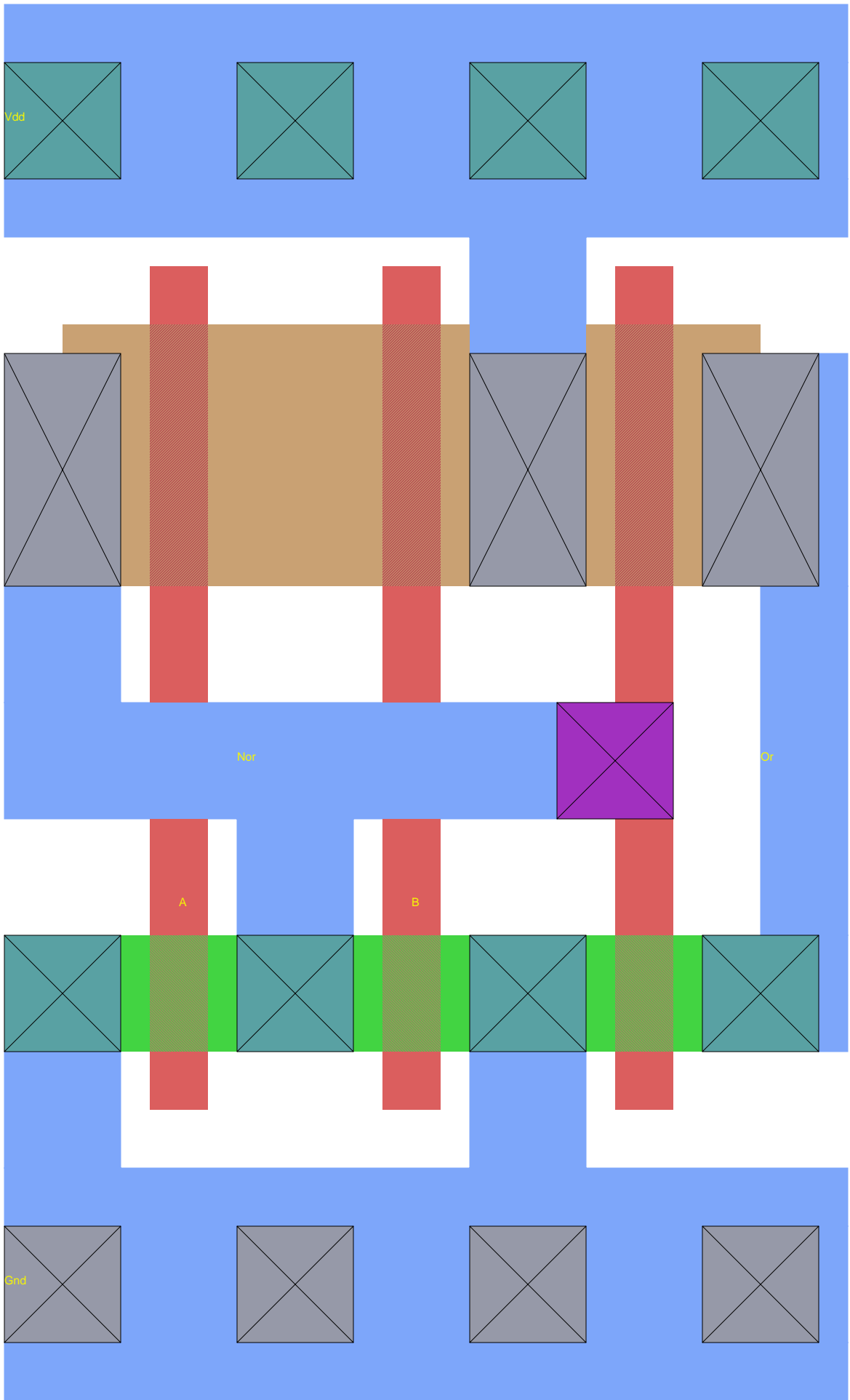

* hspice file created from or_35.ext - technology: scr

| Wave | Symbol |
|-------------|--------|
| D0:A0:v(or) | X |
| D0:A0:v(b) | ○ |
| D0:A0:v(a) | △ |

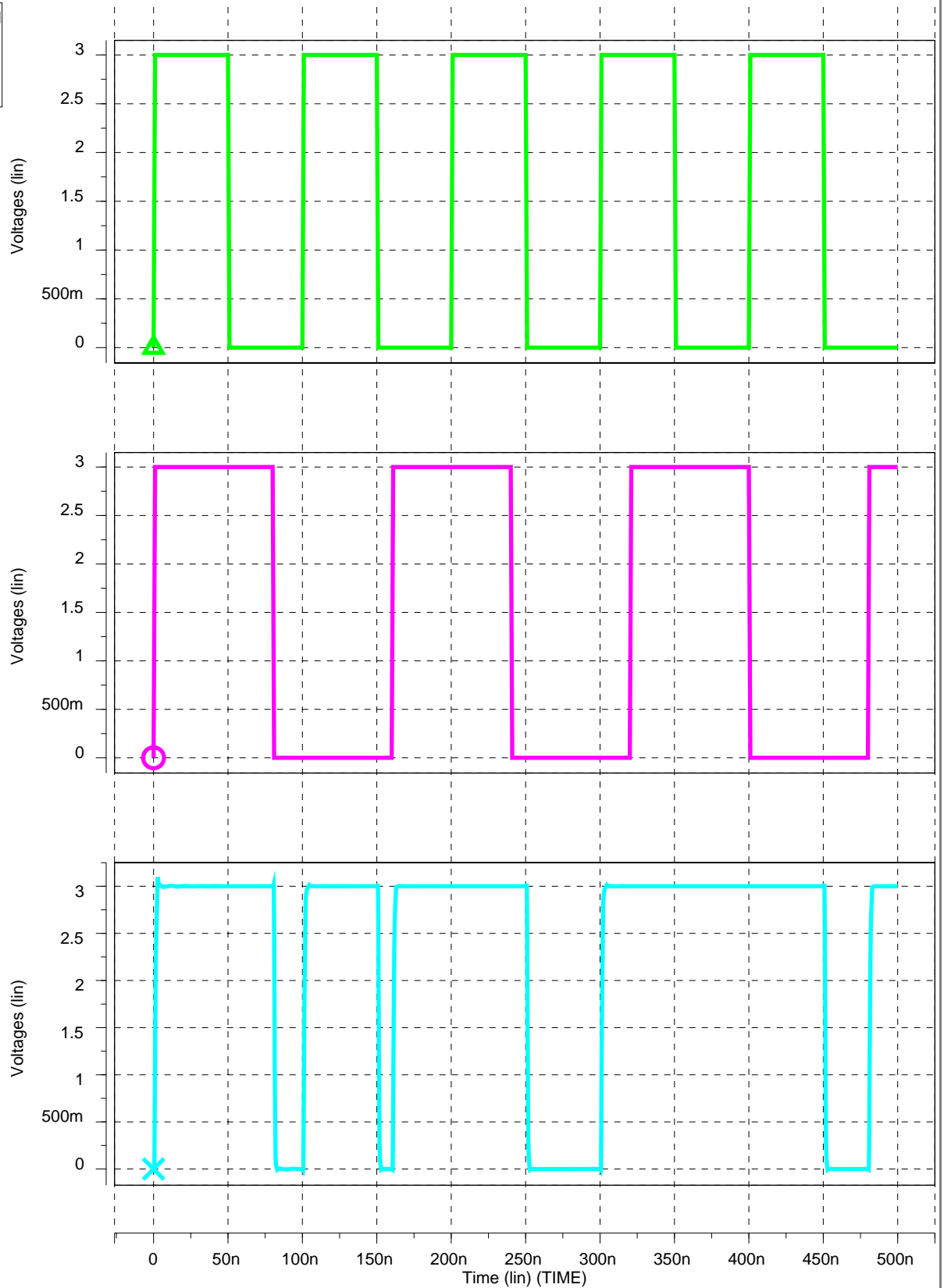

xnor_35

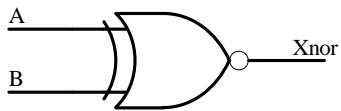
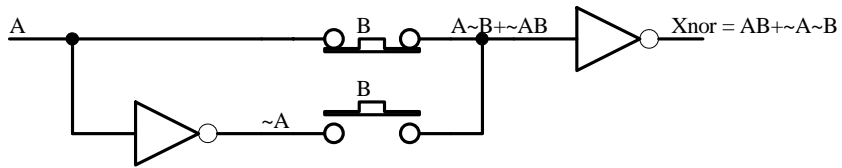
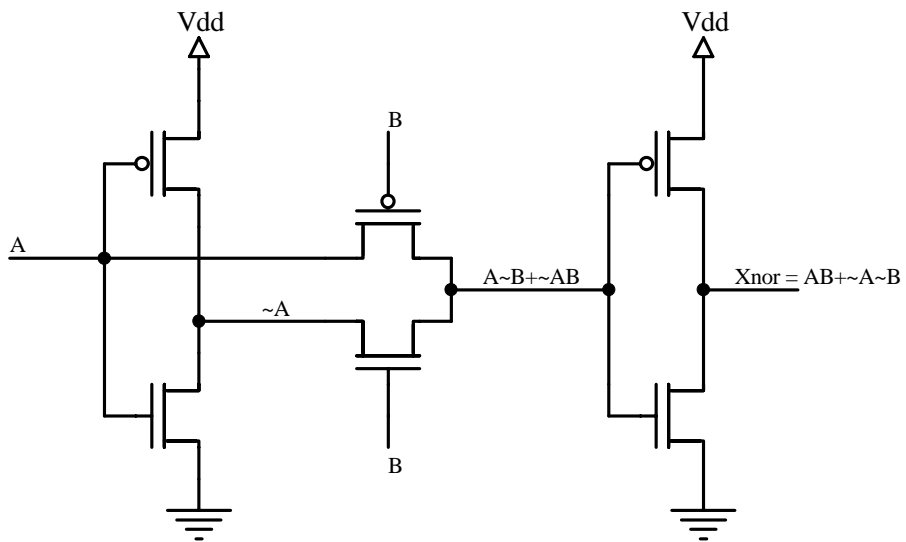

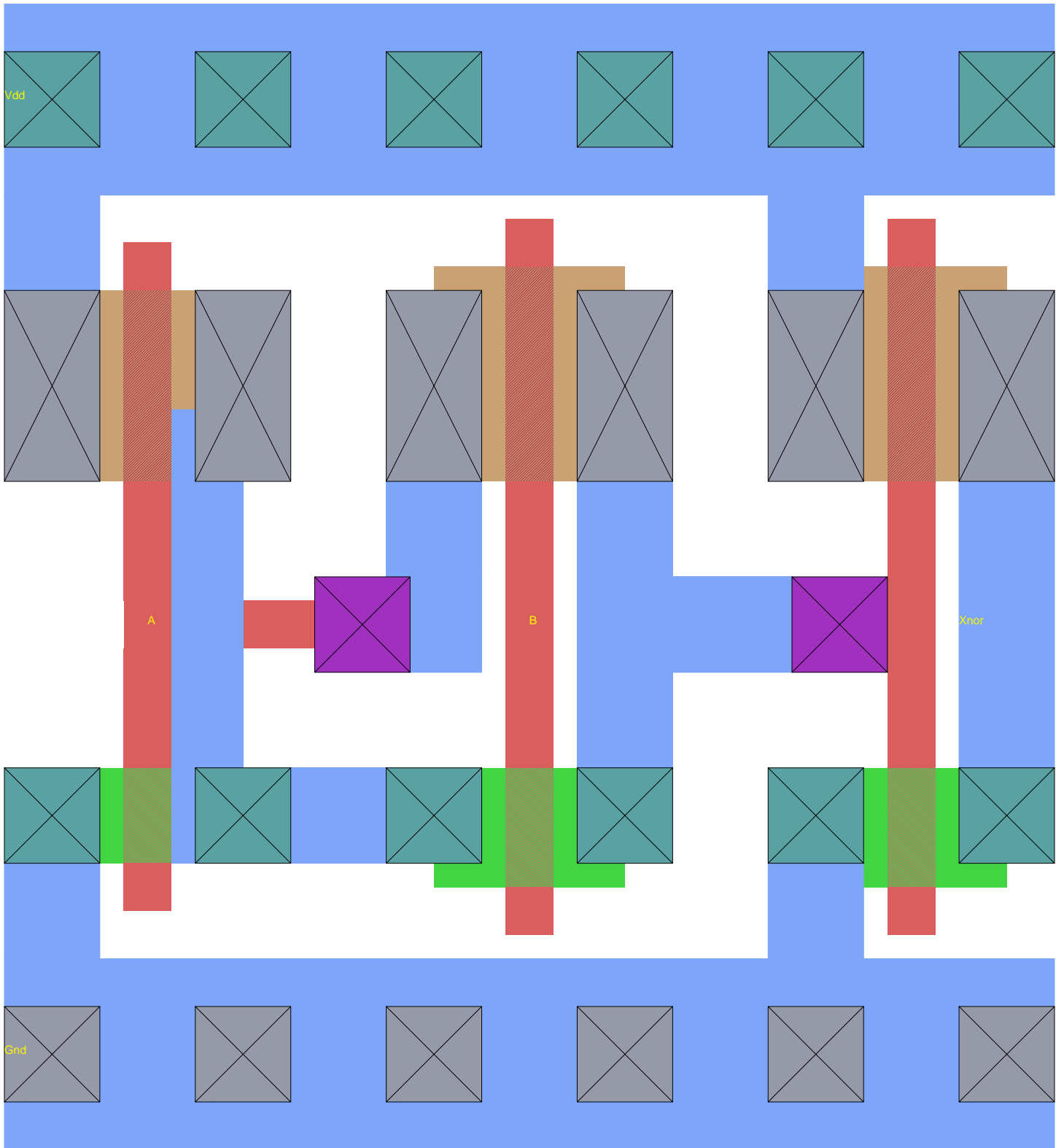

* hspice file created from xnor_35.ext - technology:

| Wave | Symbol |
|---------------|--------|
| D0:A0:v(xnor) | X |
| D0:A0:v(b) | o |
| D0:A0:v(a) | △ |

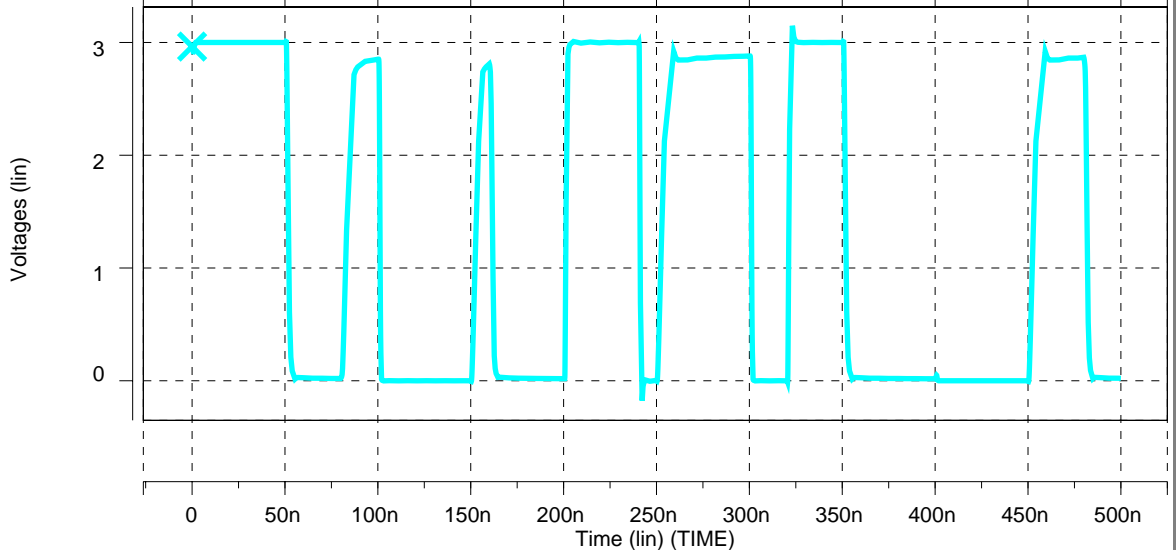
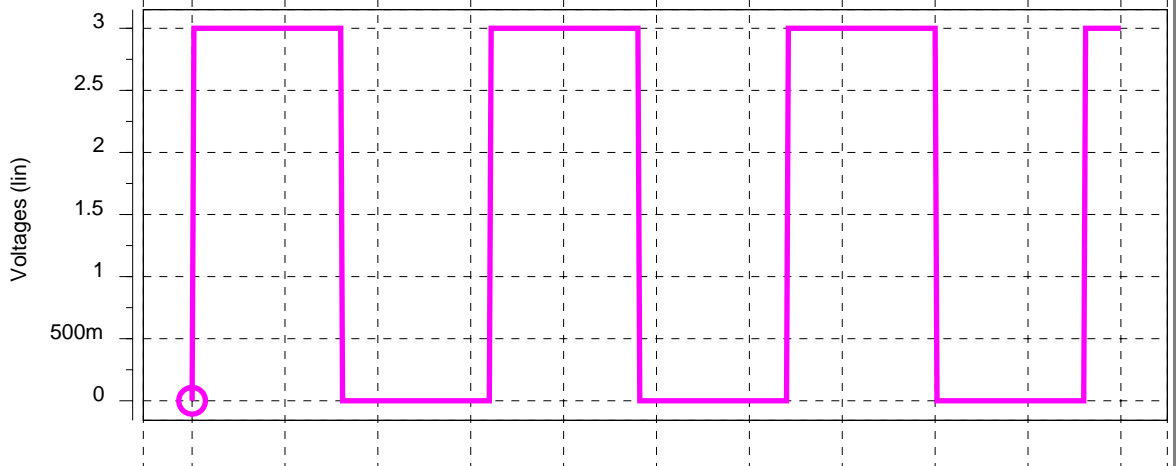
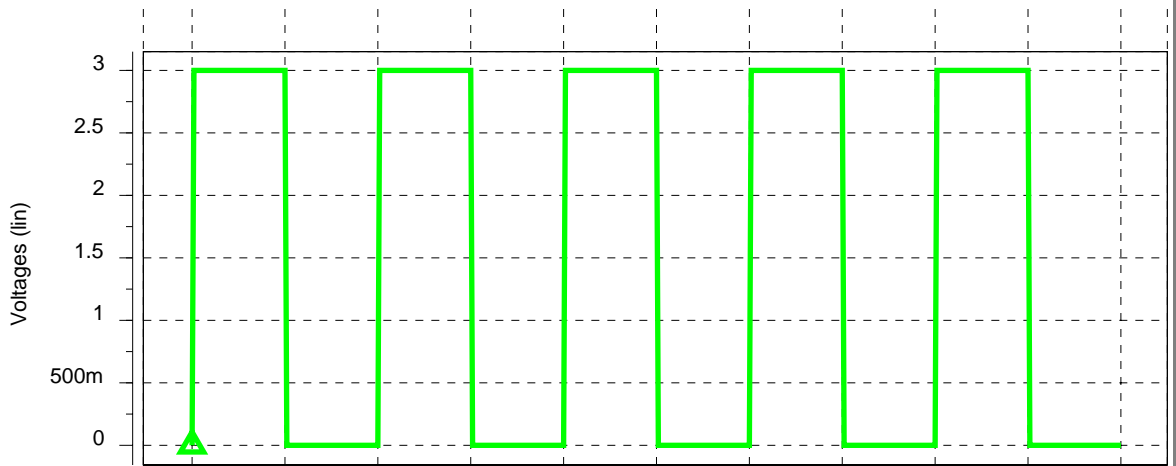

xor_35

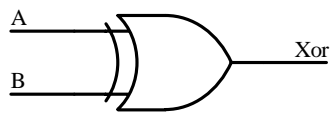
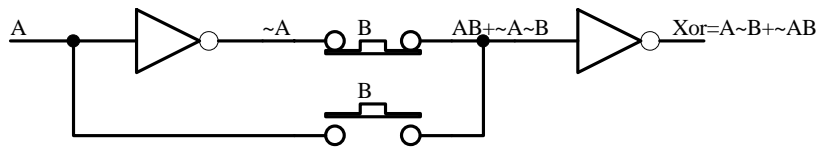
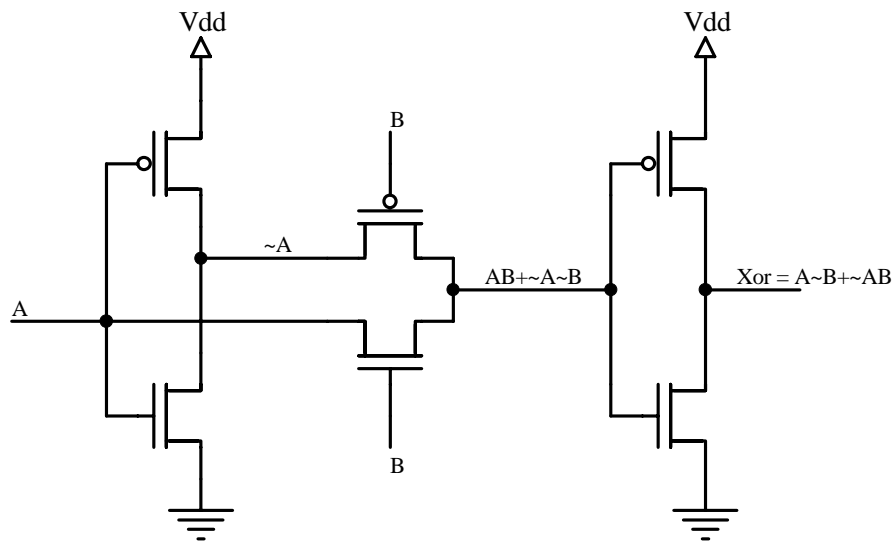

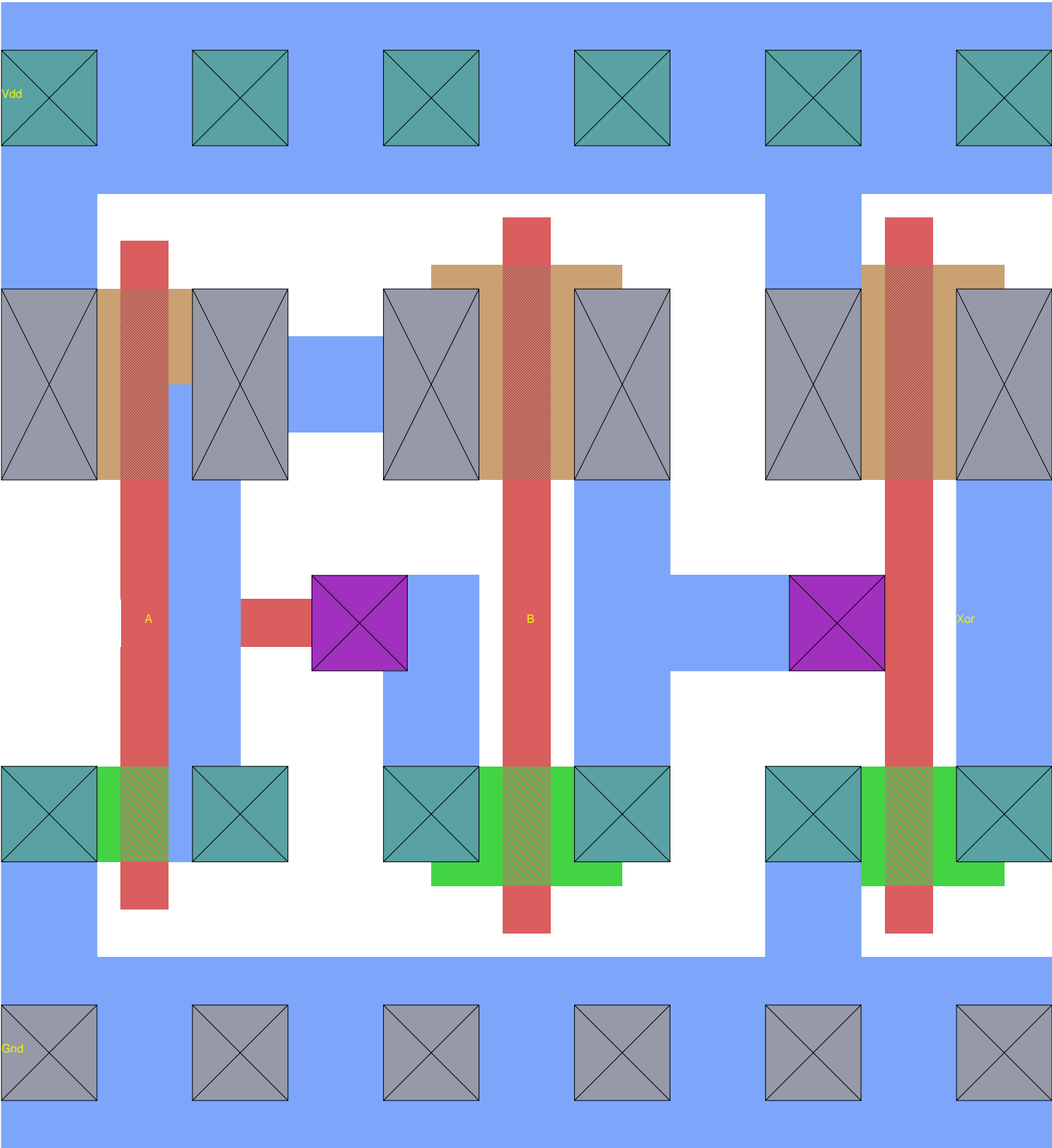

* hspice file created from xor_35.ext - technology: s

| Wave | Symbol |
|--------------|--------|
| D0:A0:v(xor) | X |
| D0:A0:v(b) | O |
| D0:A0:v(a) | △ |

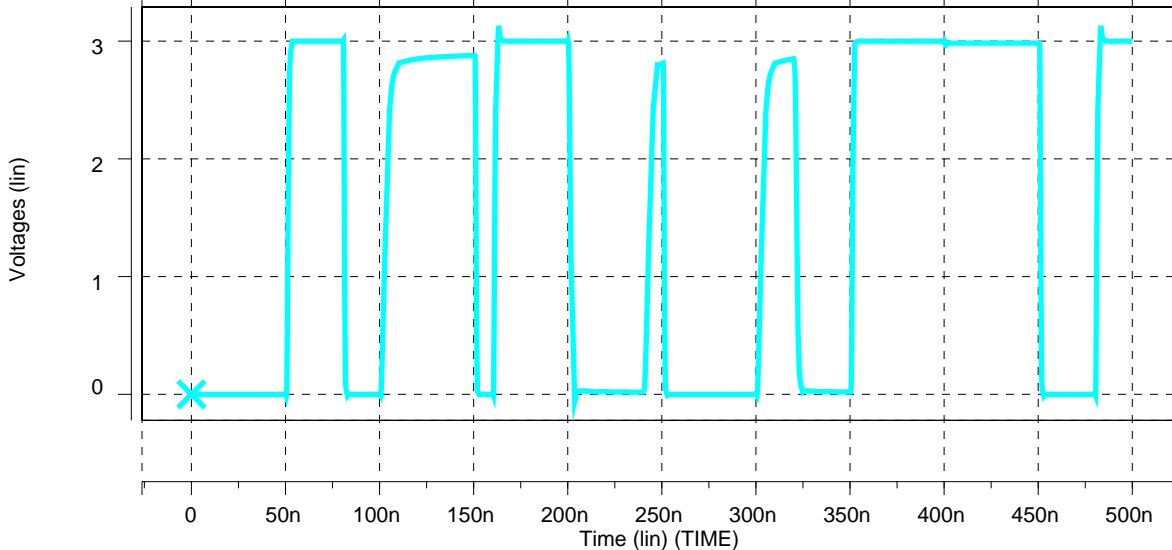
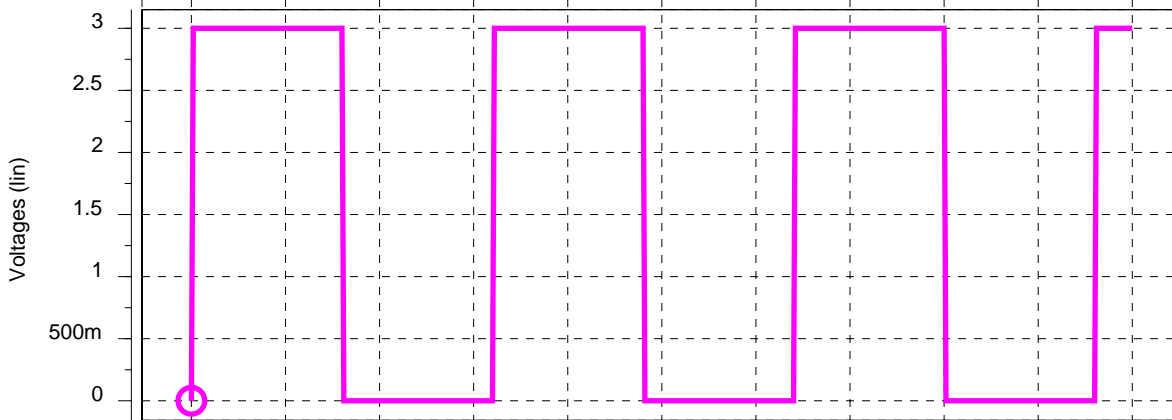
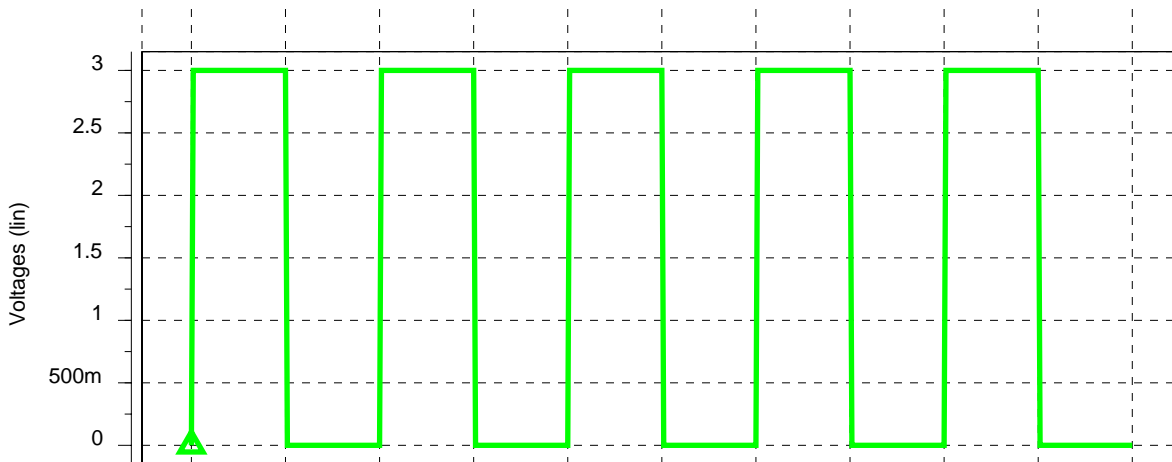

1

2

3

4

pass_35

D

D

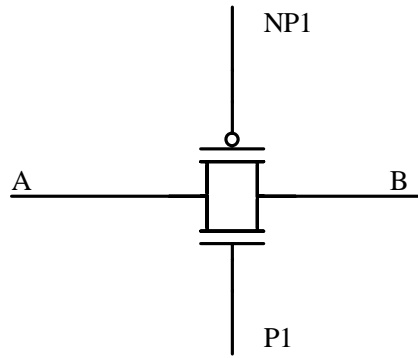

C

C

B

B

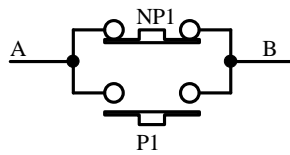

A

A

1

2

3

4

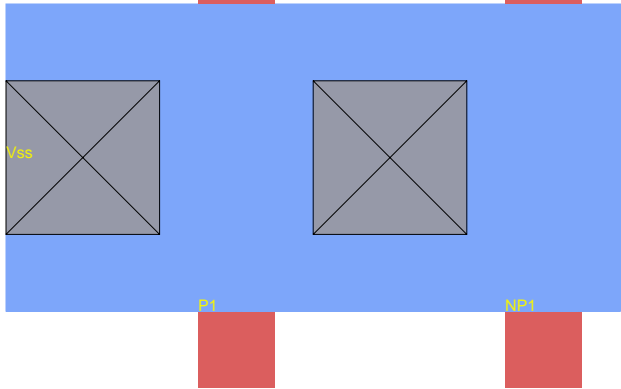
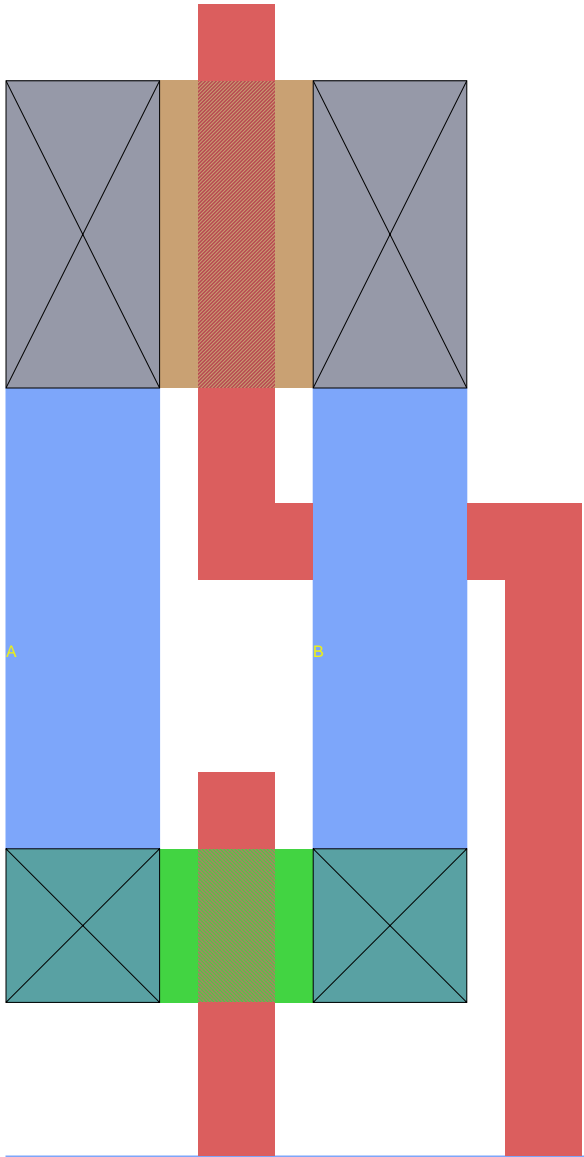
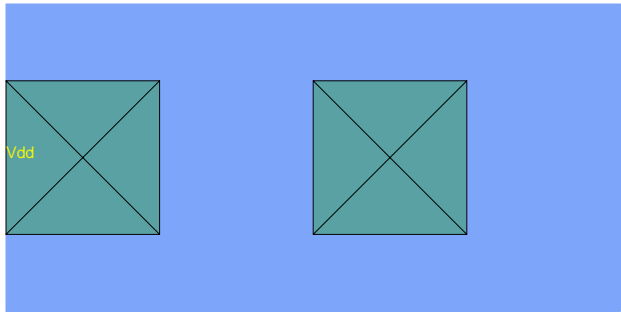

* hspice file created from pass_35.ext - technology:

| Wave | Symbol |
|--------------|--------|
| D0:A0:v(b) | X |
| D0:A0:v(np1) | ○ |
| D0:A0:v(p1) | △ |
| D0:A0:v(a) | □ |

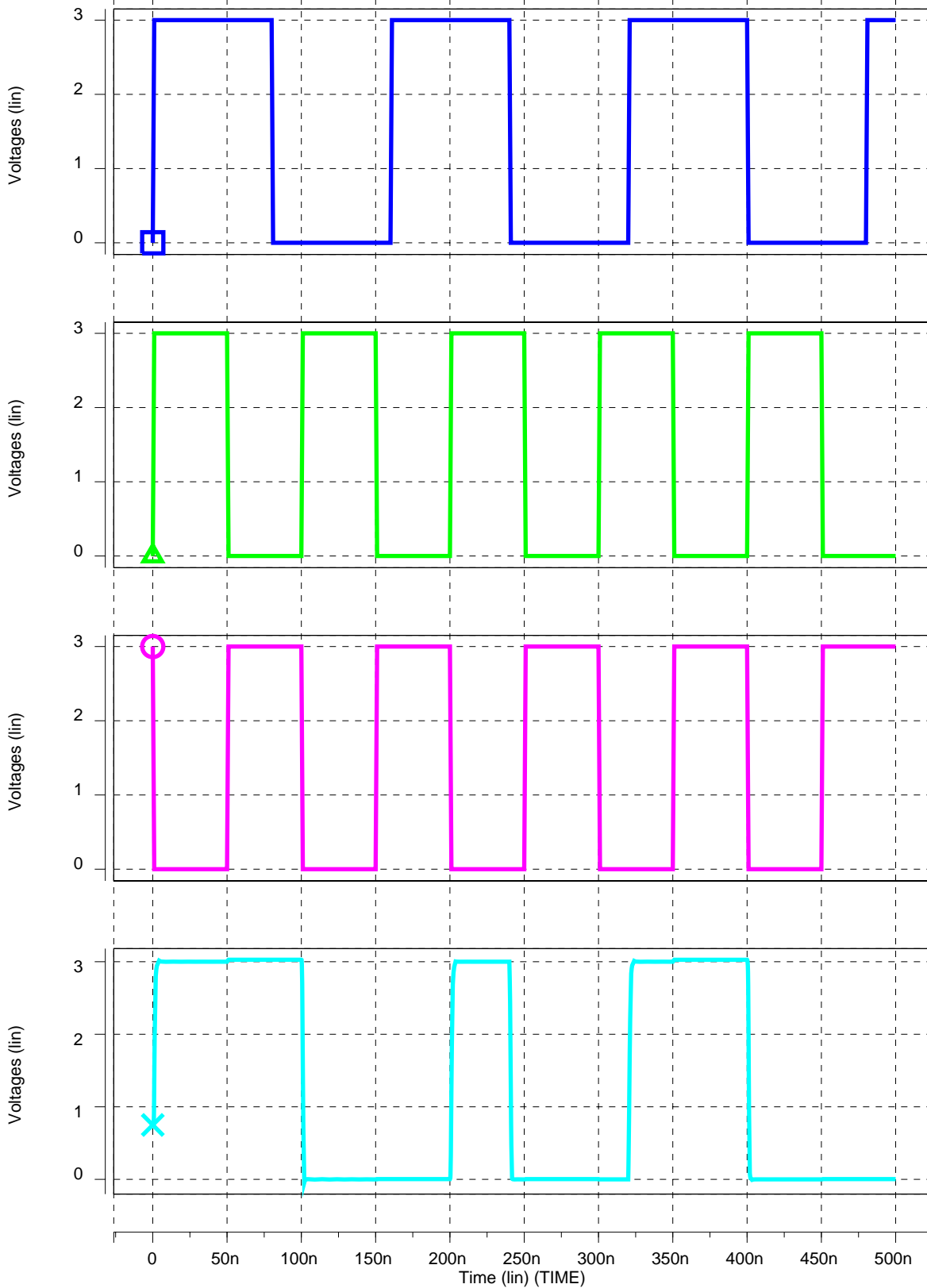

latch_35

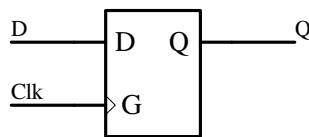
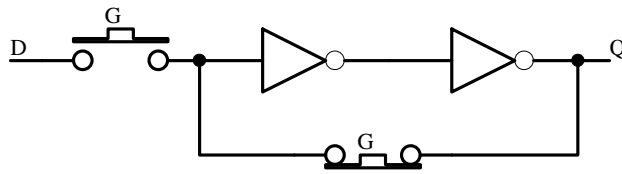
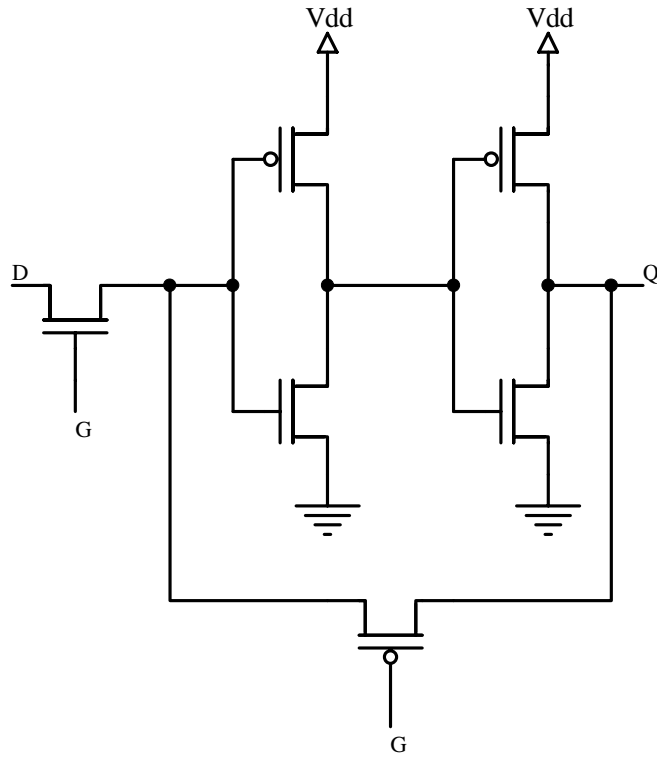

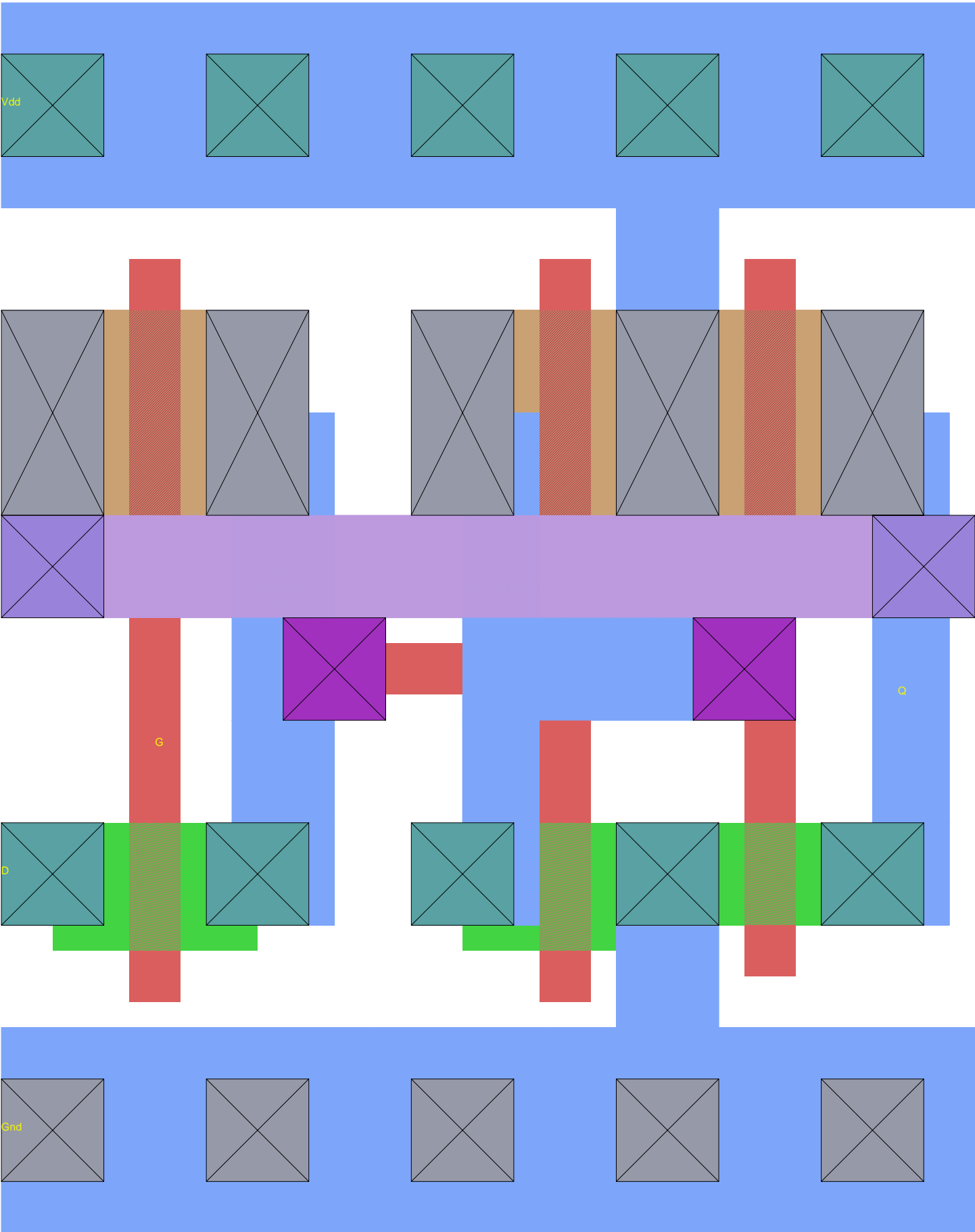

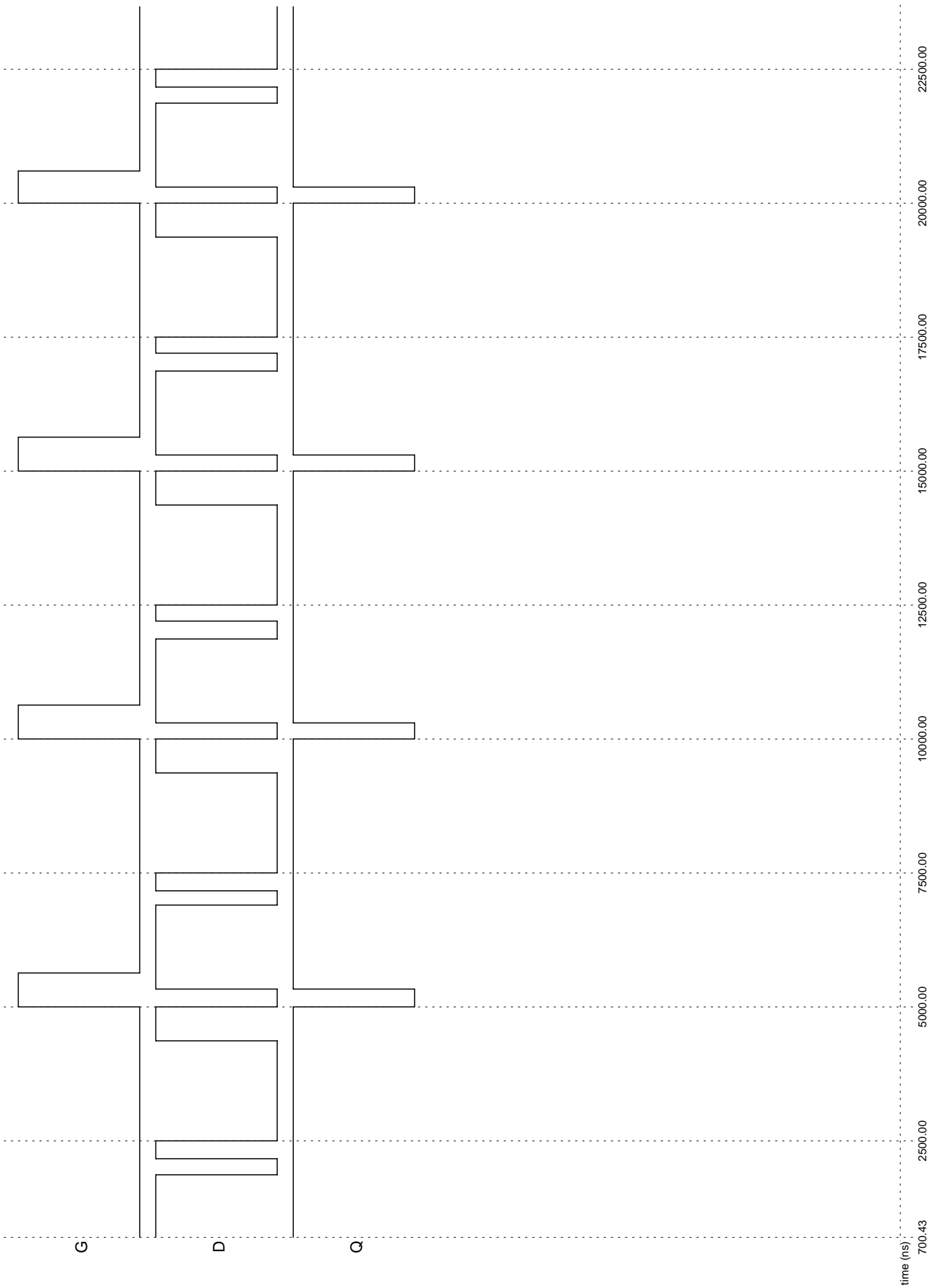

dff1_35

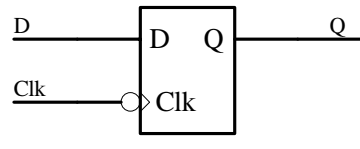
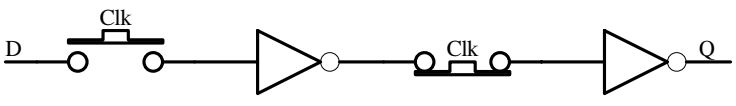
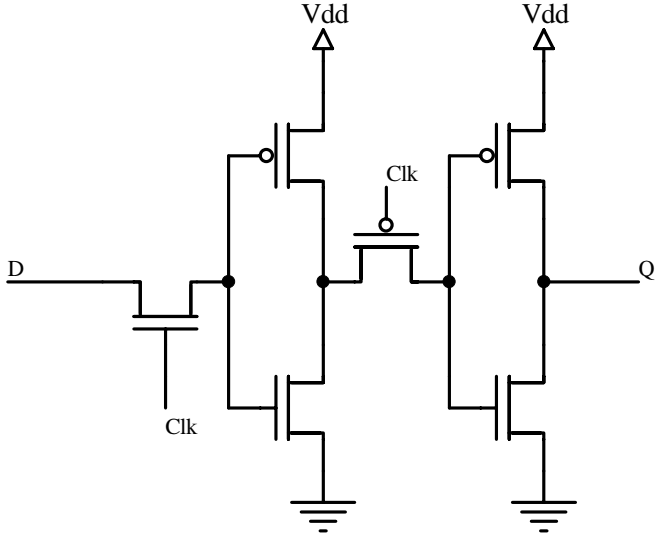

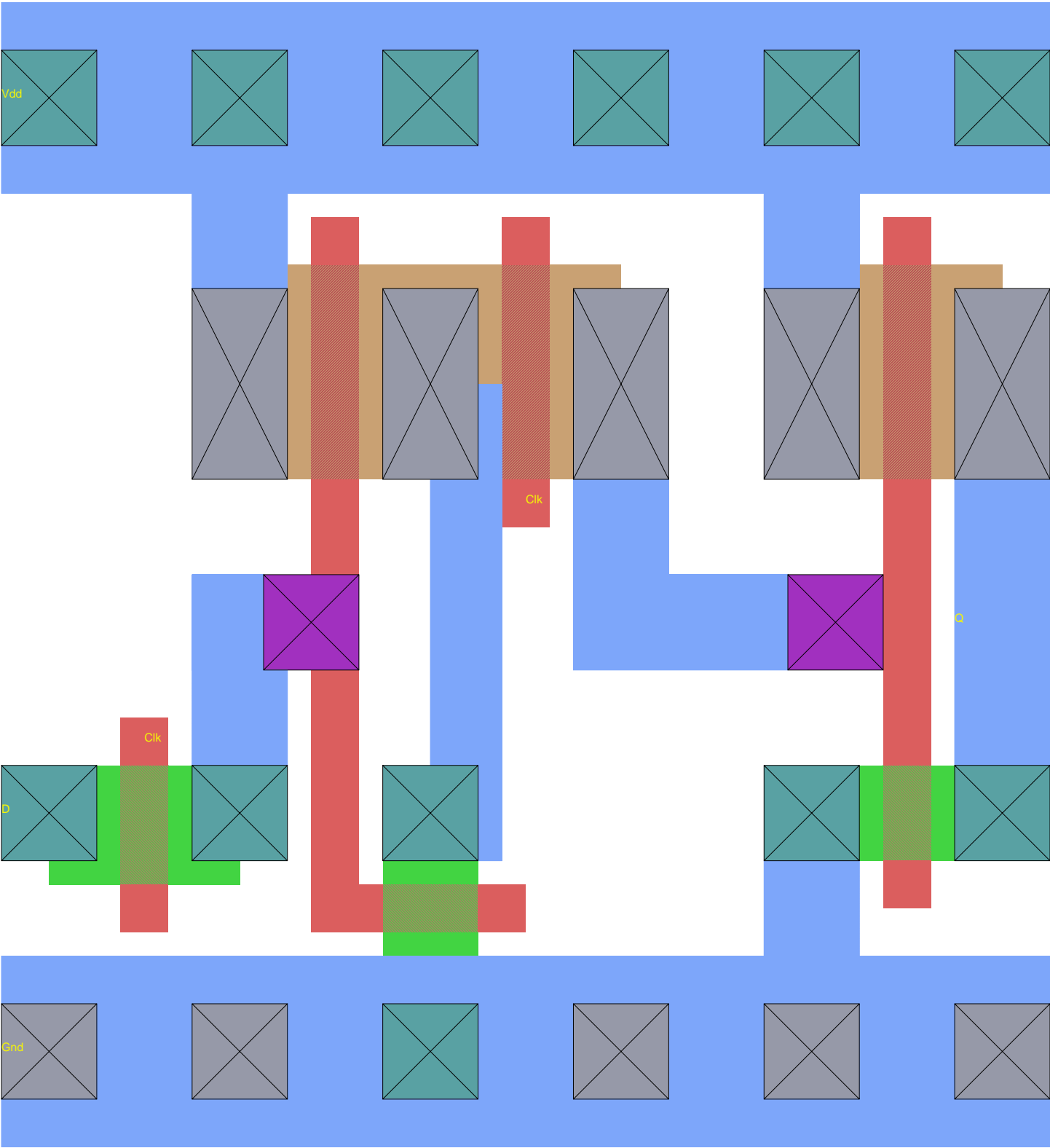

* hspice file created from dff1_35.ext - technology: s

| Wave | Symbol |
|--------------|--------|
| D0:A0:v(q) | X |
| D0:A0:v(d) | o |
| D0:A0:v(clk) | △ |

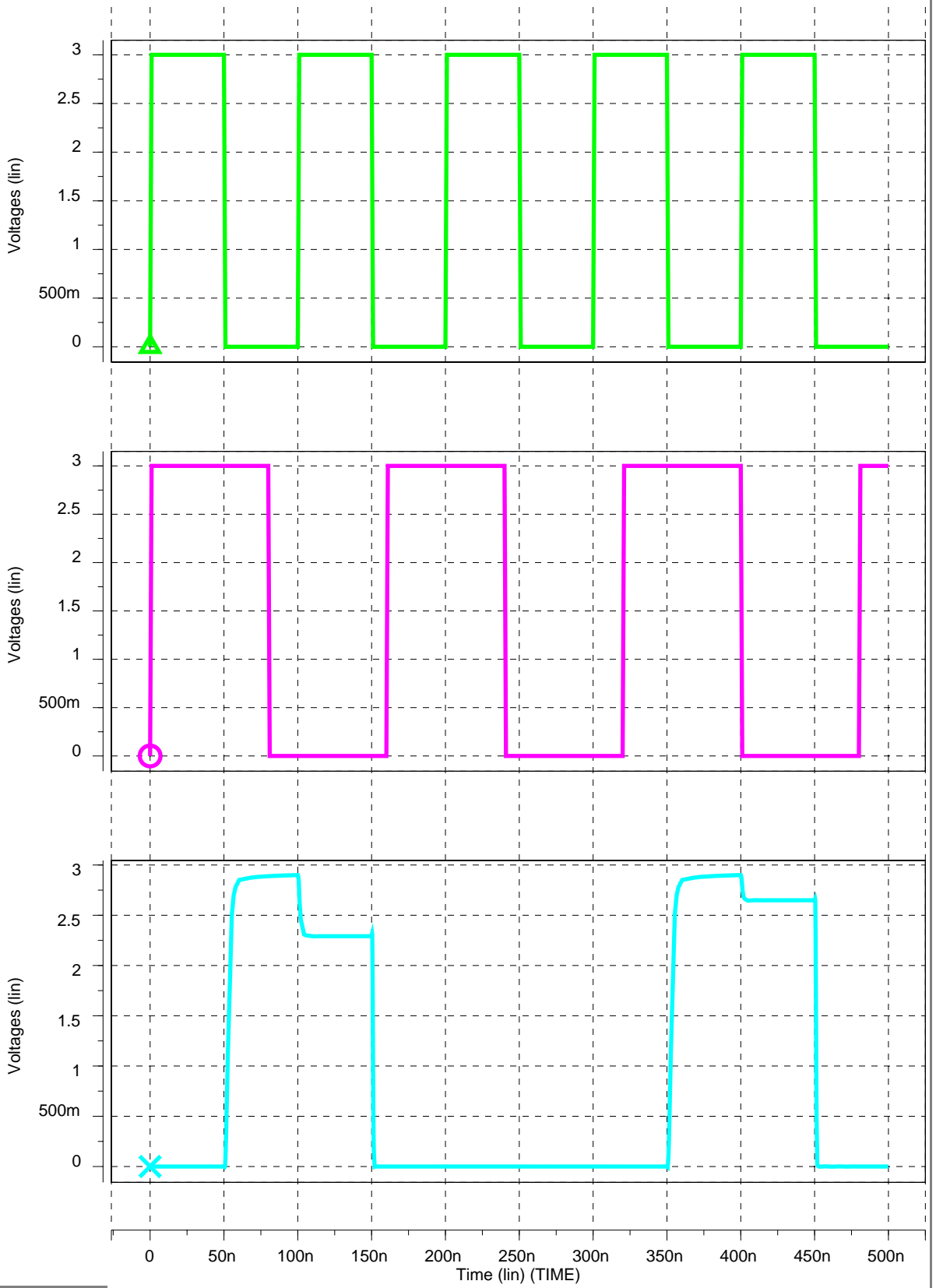

dff3_35

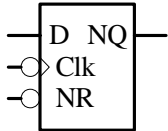
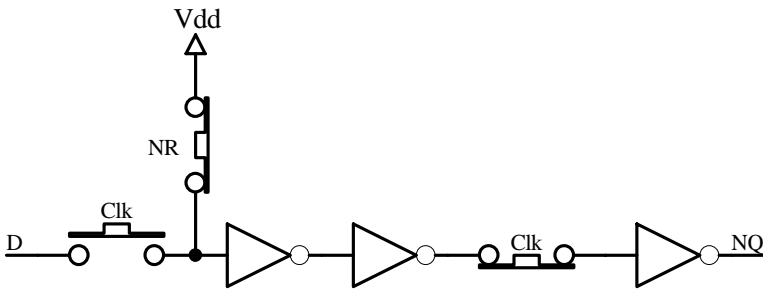
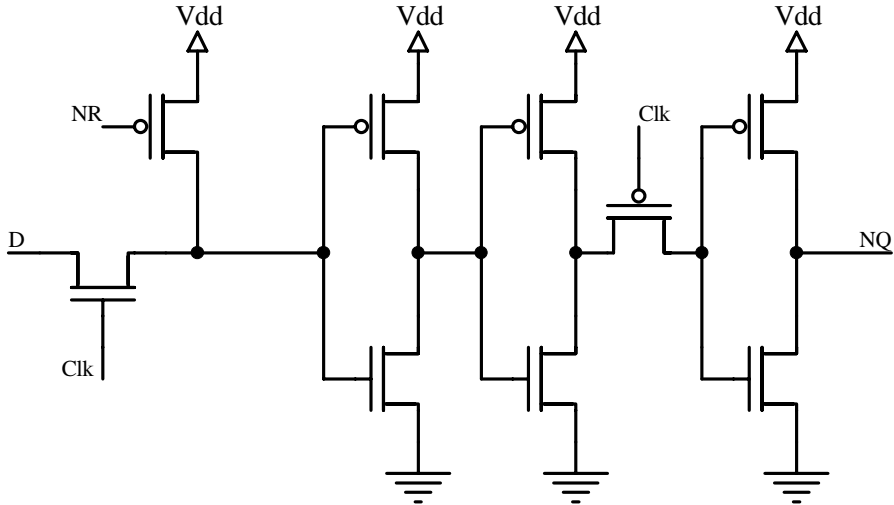

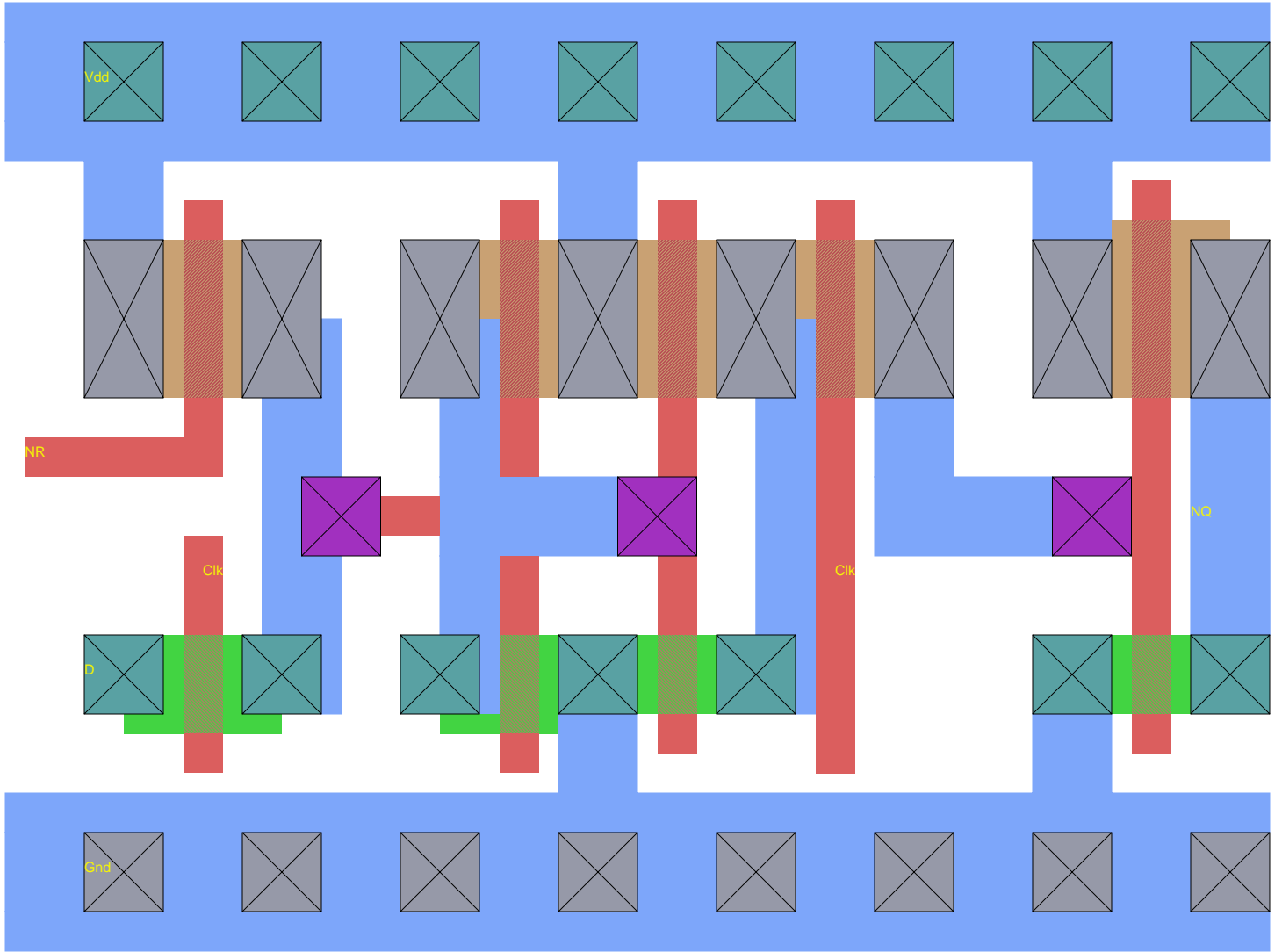

* hspice file created from dff3_35.ext - technology: s

| Wave | Symbol |
|--------------|--------|
| D0:A0:v(nq) | X |
| D0:A0:v(d) | ○ |
| D0:A0:v(nr) | △ |
| D0:A0:v(clk) | □ |

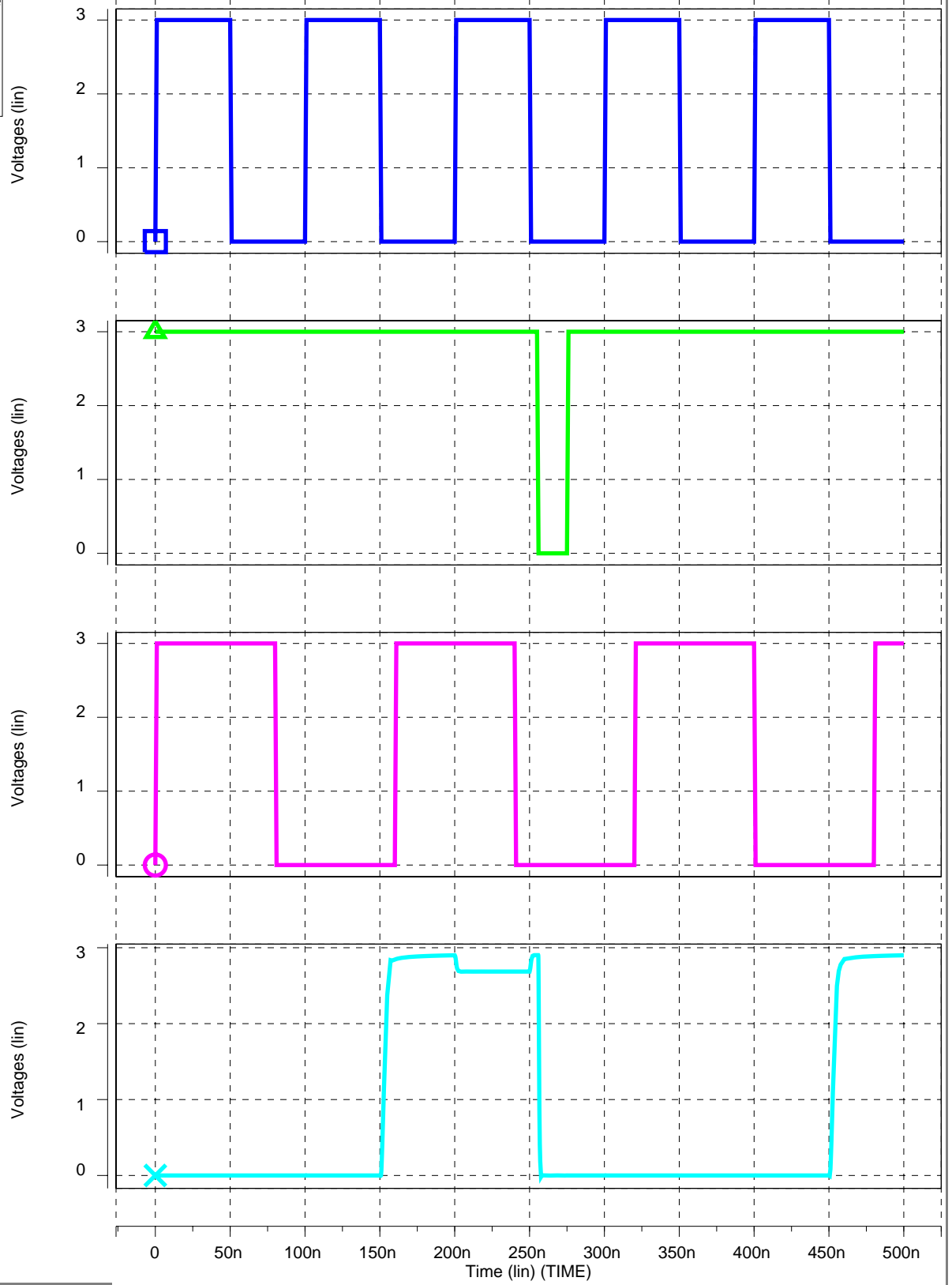

dff7_35

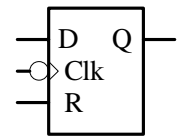
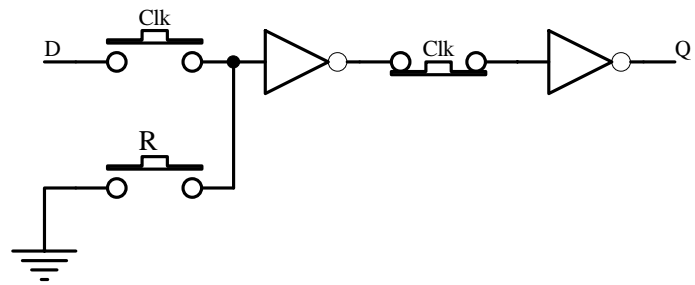
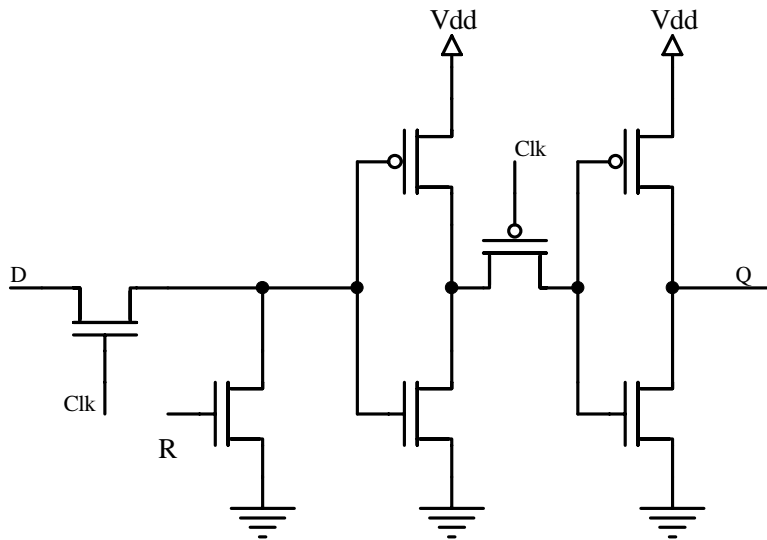

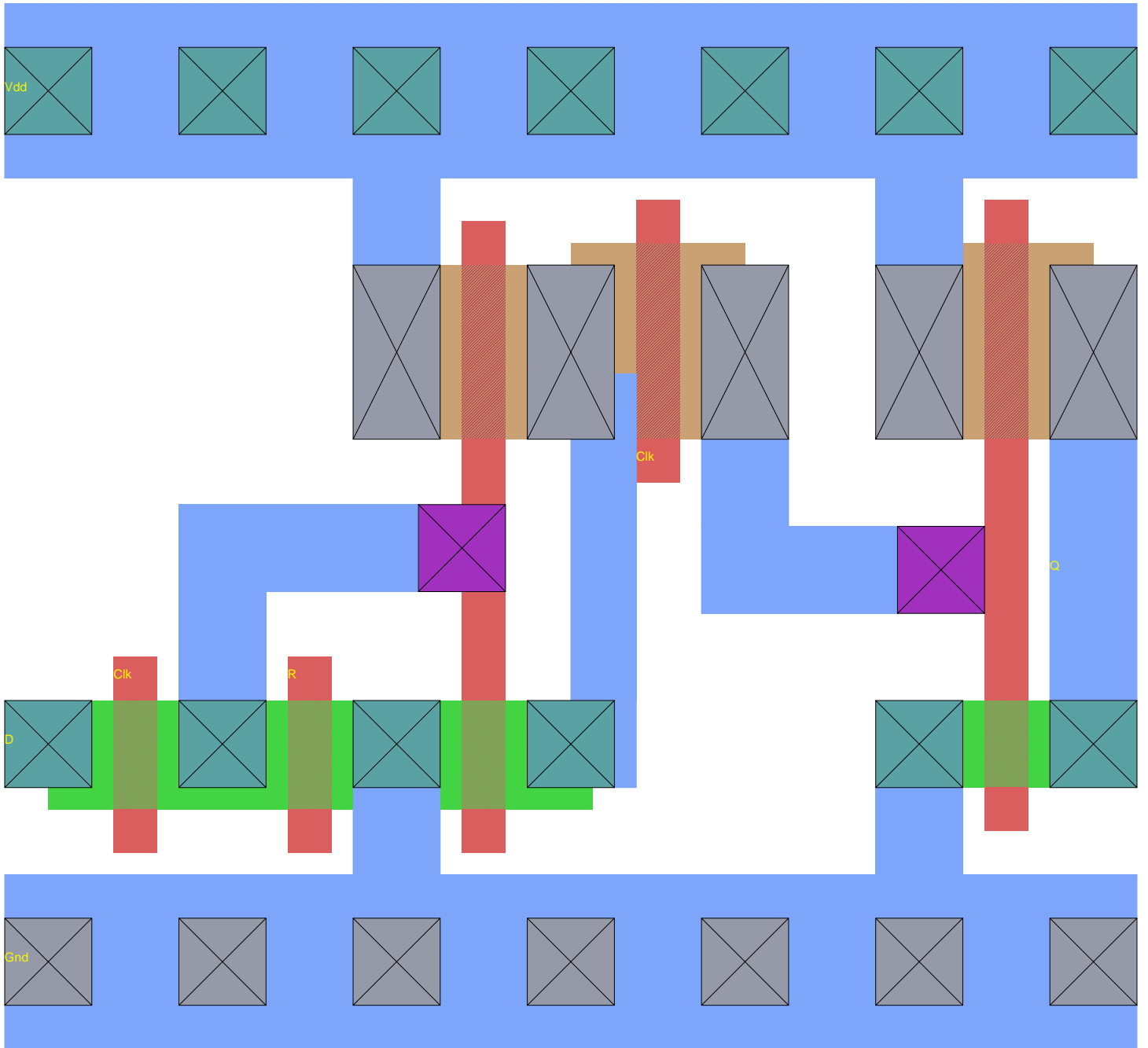

* hspice file created from dff7_35.ext - technology: s

| Wave | Symbol |
|--------------|--------|
| D0:A0:v(q) | X |
| D0:A0:v(d) | ○ |
| D0:A0:v(r) | △ |
| D0:A0:v(clk) | □ |

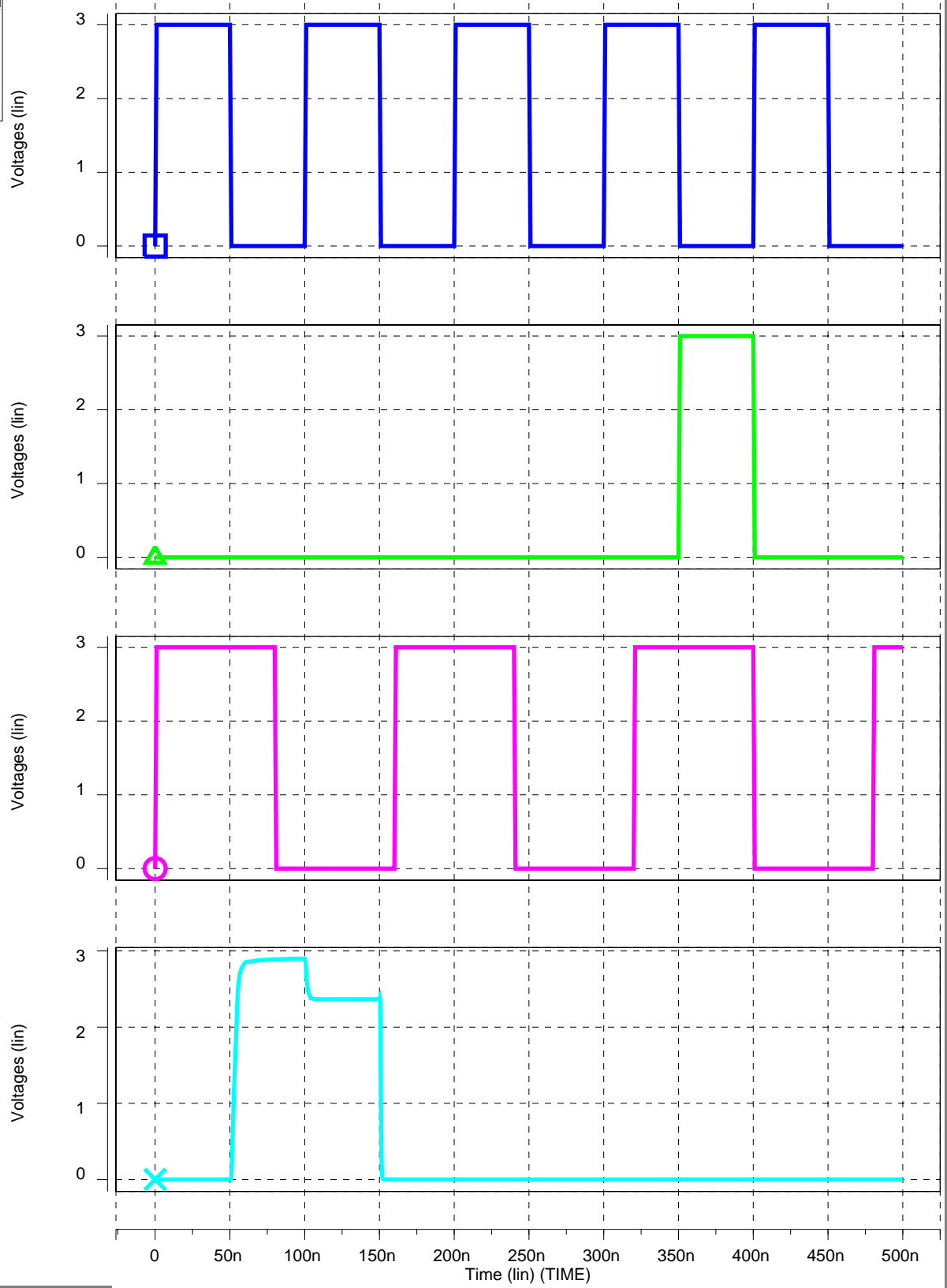

1badd1_35

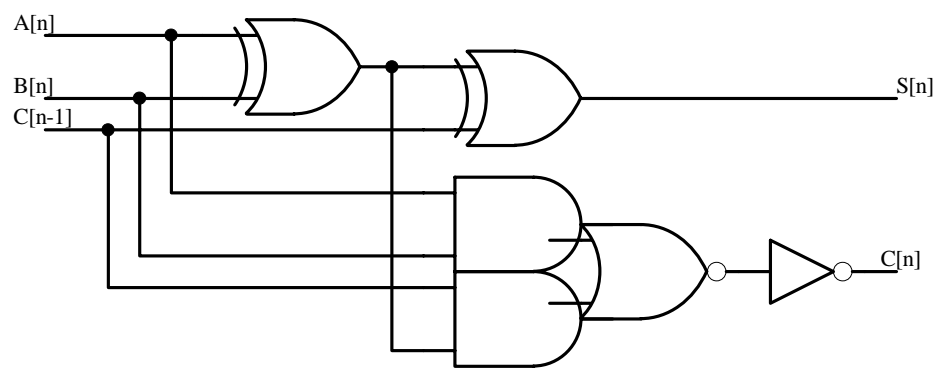
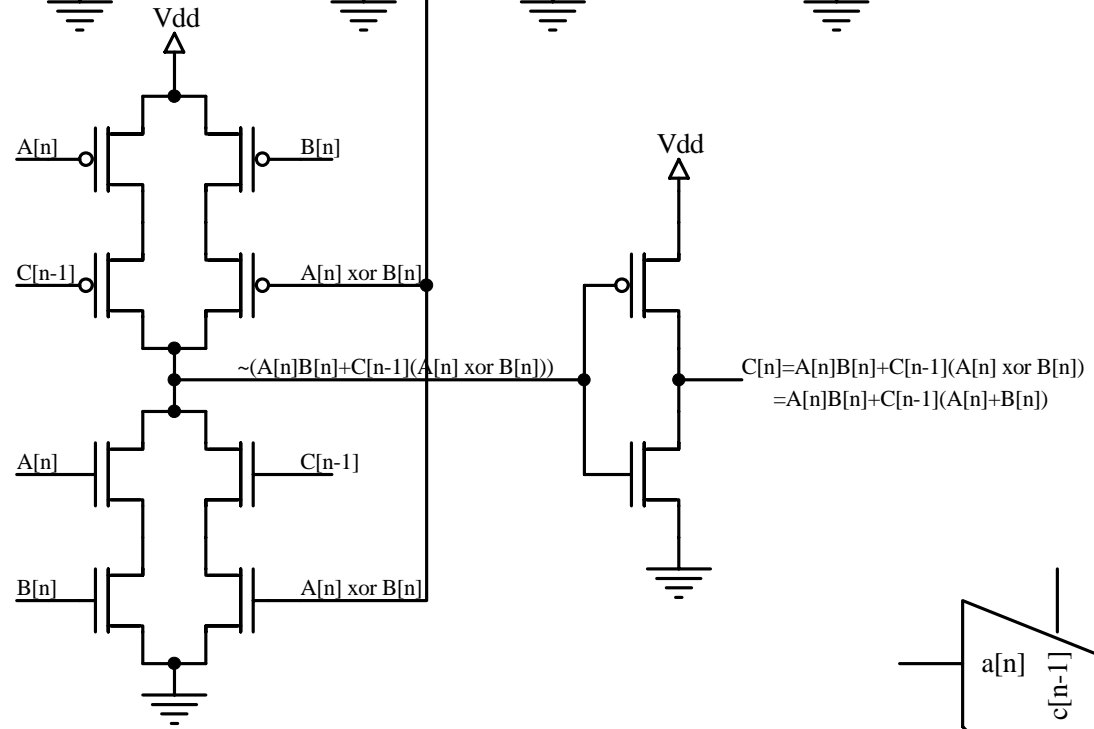
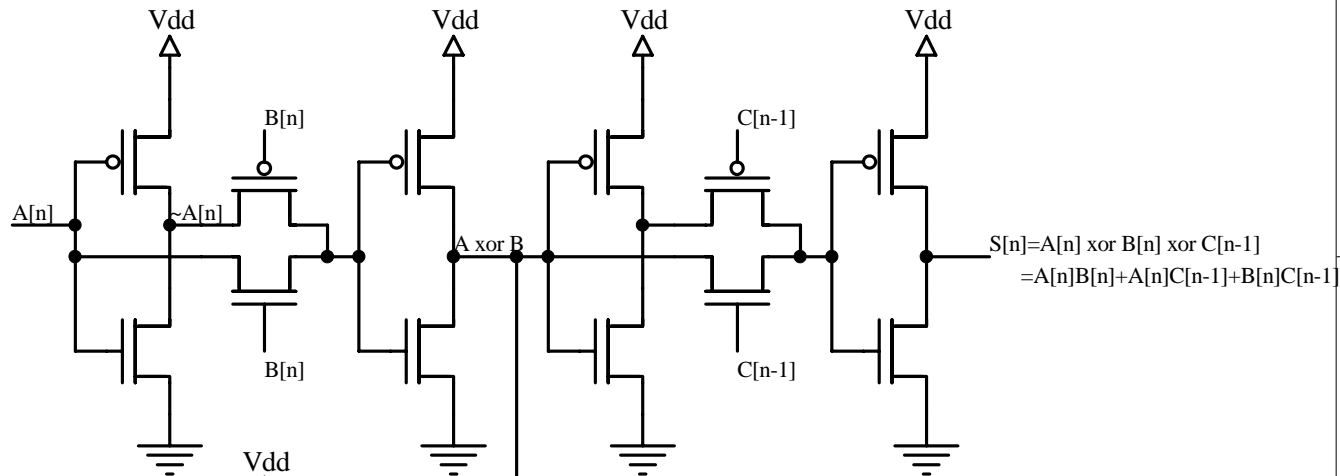

Combined AND/NOR

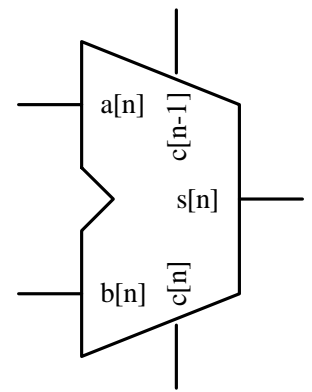

1

2

3

4

D

D

C

C

B

B

A

A

1

2

3

4

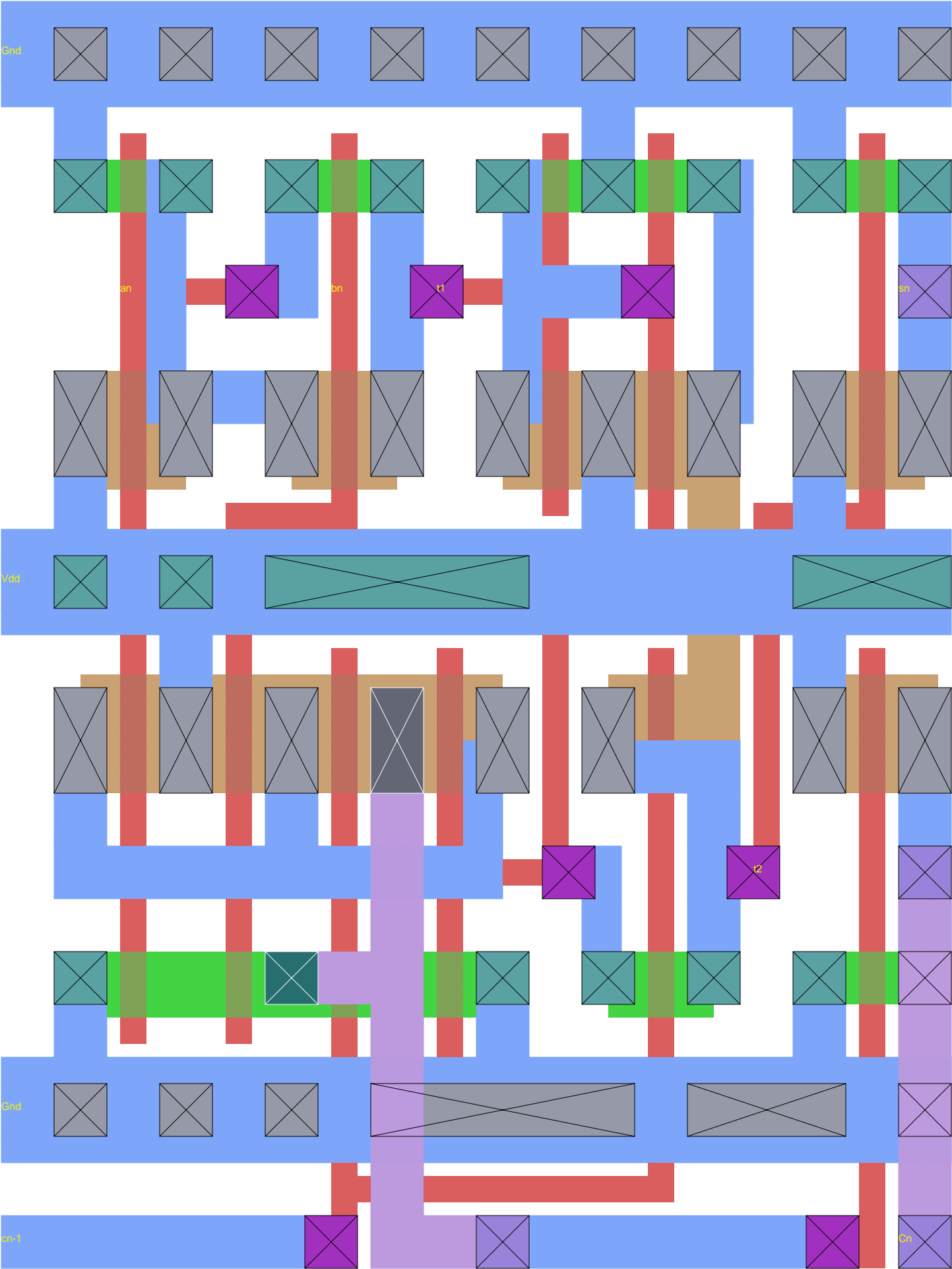

* hspice file created from 1badd1_35.ext - technolog

| Wave | Symbol |
|---------------|--------|
| D0:A0:v(cn) | ✕ |
| D0:A0:v(sn) | ○ |
| D0:A0:v(cn-1) | △ |
| D0:A0:v(bn) | □ |
| D0:A0:v(an) | ✕ |

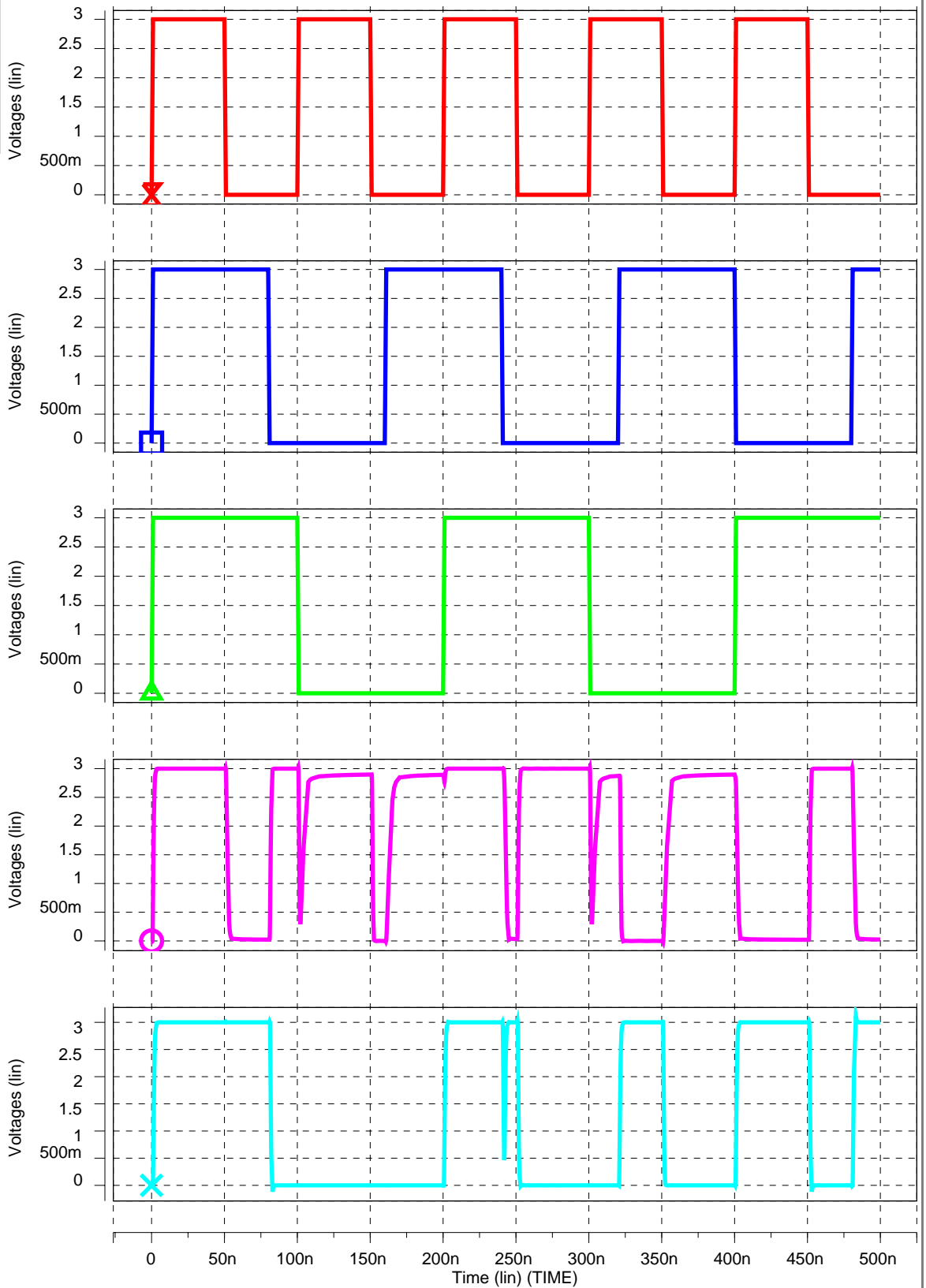

1

2

3

4

Generic ROM bit cells, used in both dynamic and static ROM implementations

rombit_35

D

D

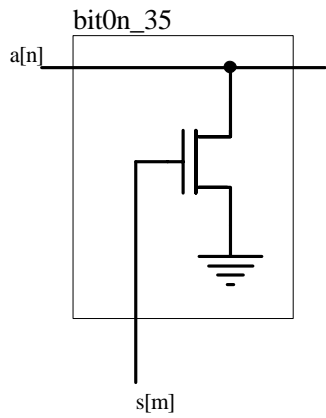

- used as '1' in dynamic ROMs
- used as '0' pull down in static ROMs

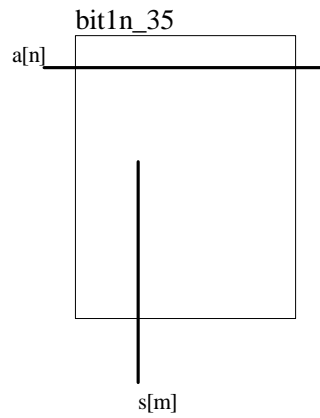

- used as '0' in dynamic ROMs
- used as '1' in static ROMs

C

C

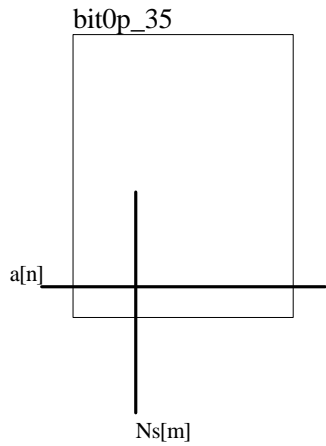

- used as '0' in static ROMs

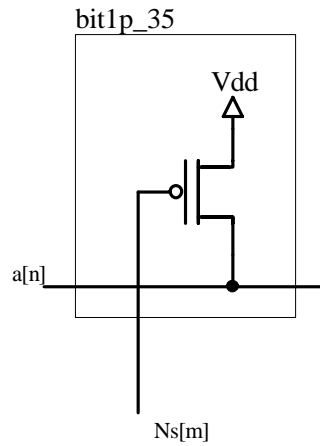

- used as '1' pull up in static ROMs

B

B

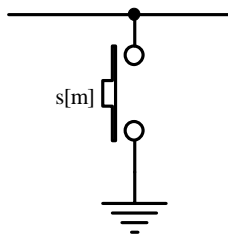

Ns[m]

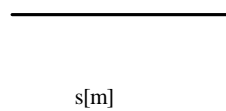

s[m]

A

A

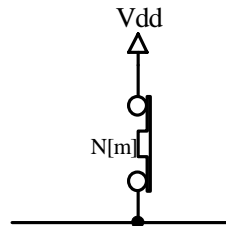

Ns[m]

1

2

3

4

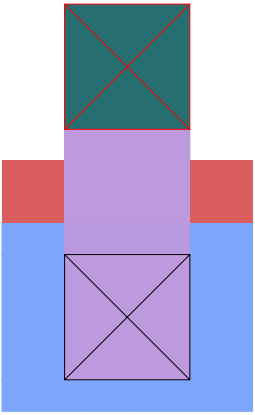

rombit0n_35

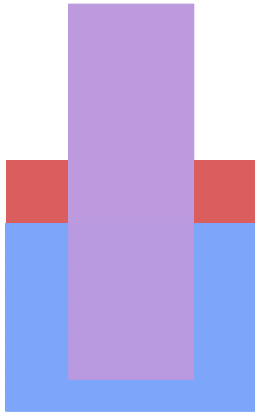

rombit1n_35

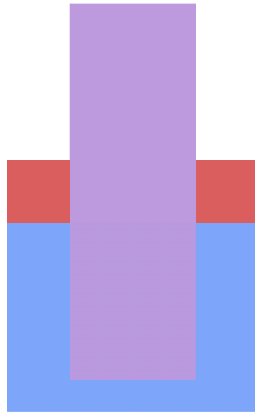

rombit0p_35

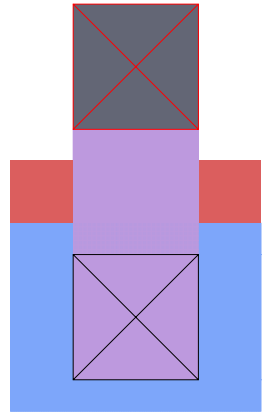

rombit1p_35

1

2

3

4

romd8x16_35

Implementation of a dynamic ROM

Note: Read occurs during Clk high

$n = 0..7, m = 0..15$

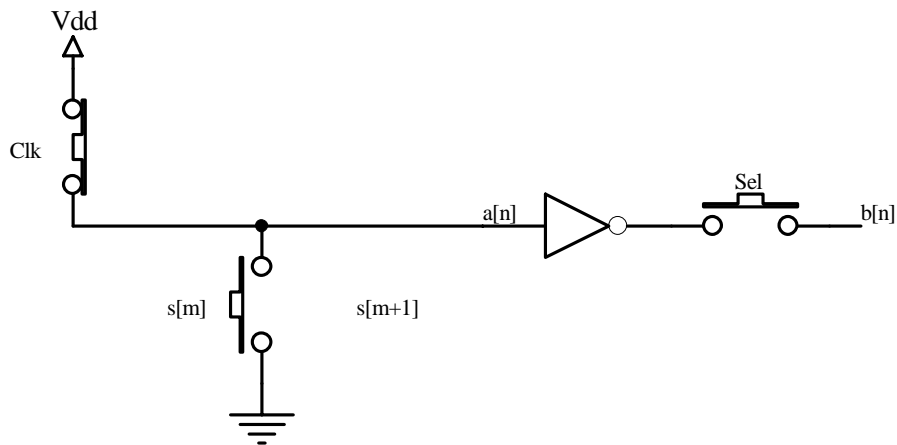
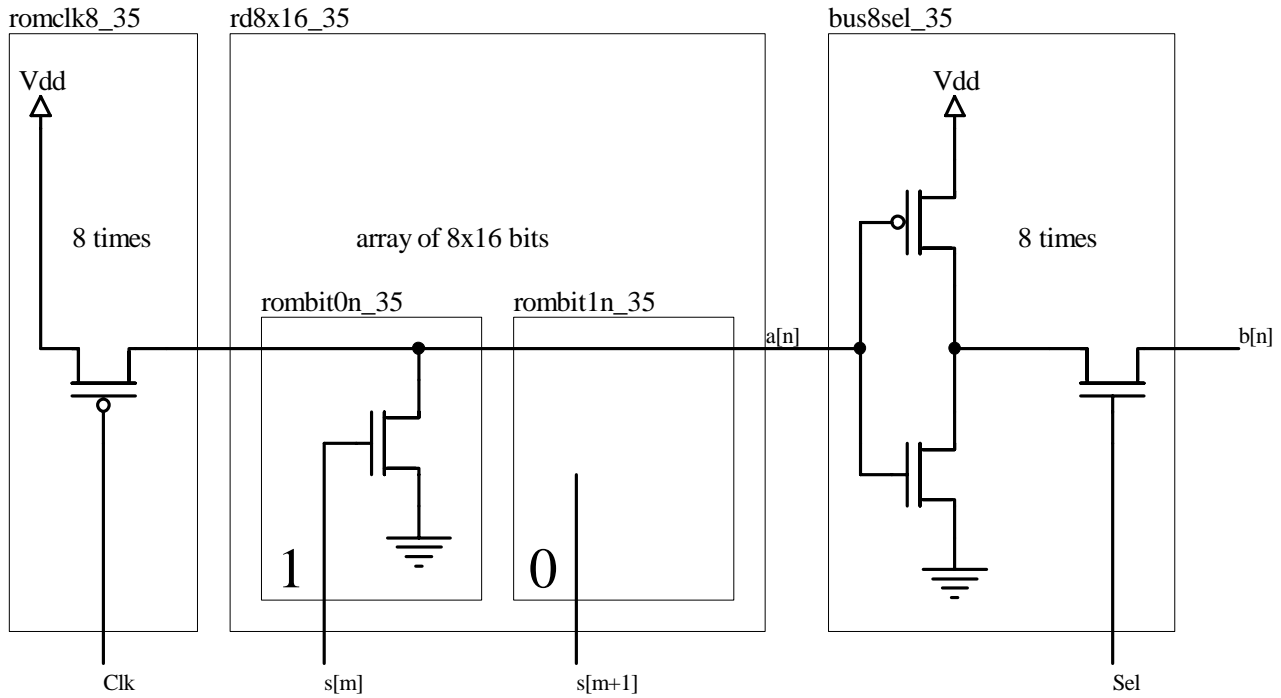

1

2

3

4

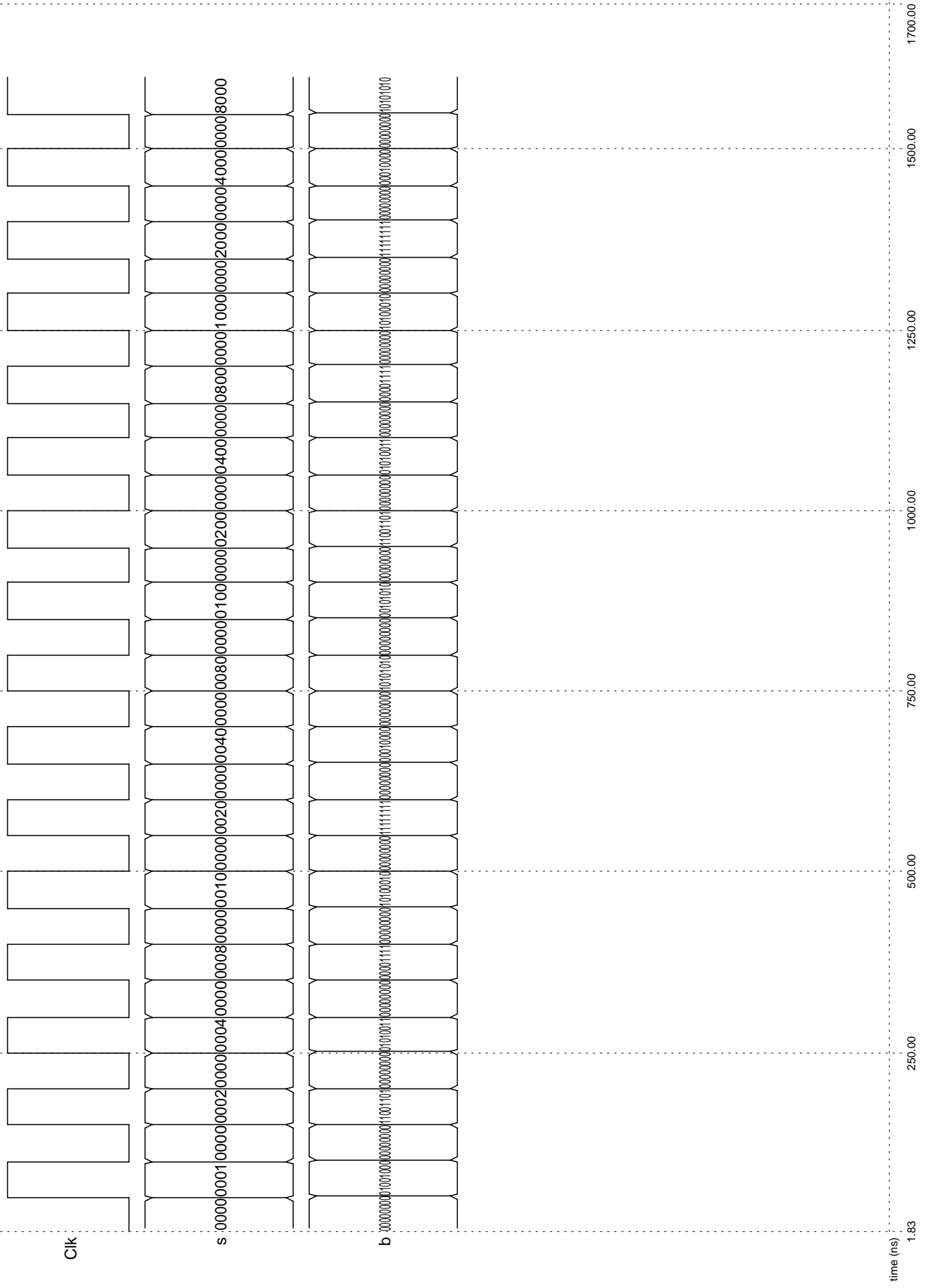

1

2

3

4

D

D

rom8clk_35

C

C

B

B

A

A

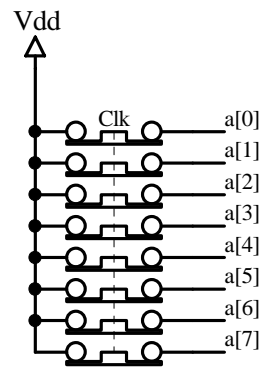
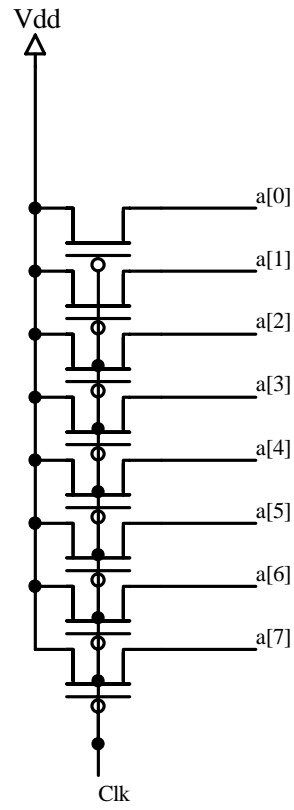

1

2

3

4

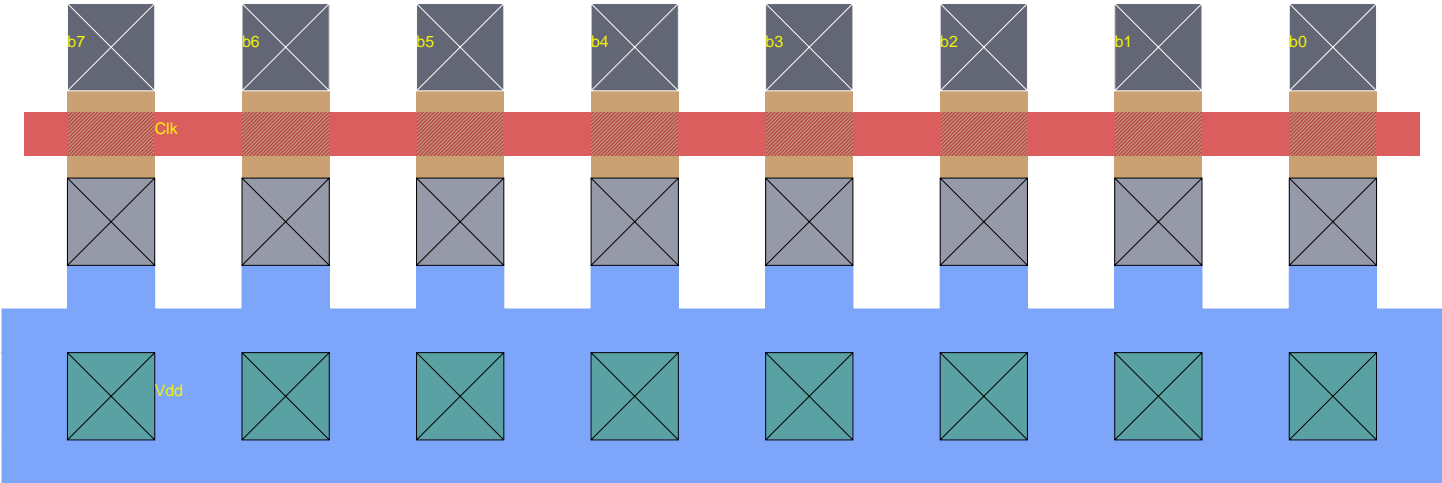
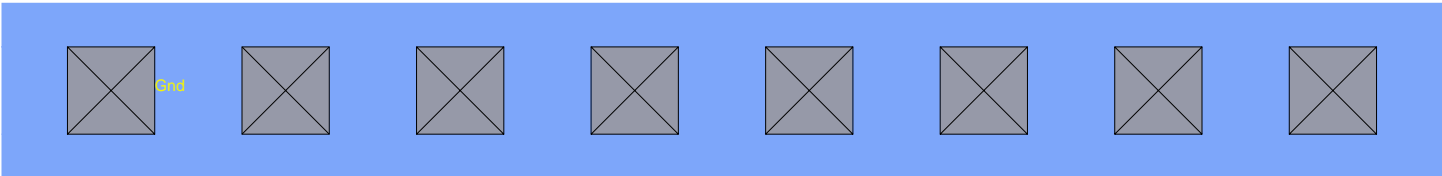

* hspice file created from rom8clk_35.ext - technology

| Wave | Symbol |
|--------------|--------|
| D0:A0:v(b7) | ✕ |
| D0:A0:v(b6) | ○ |
| D0:A0:v(b5) | △ |
| D0:A0:v(b4) | □ |
| D0:A0:v(b3) | × |
| D0:A0:v(b2) | * |
| D0:A0:v(b1) | + |
| D0:A0:v(b0) | ◇ |
| D0:A0:v(clk) | ✕ |

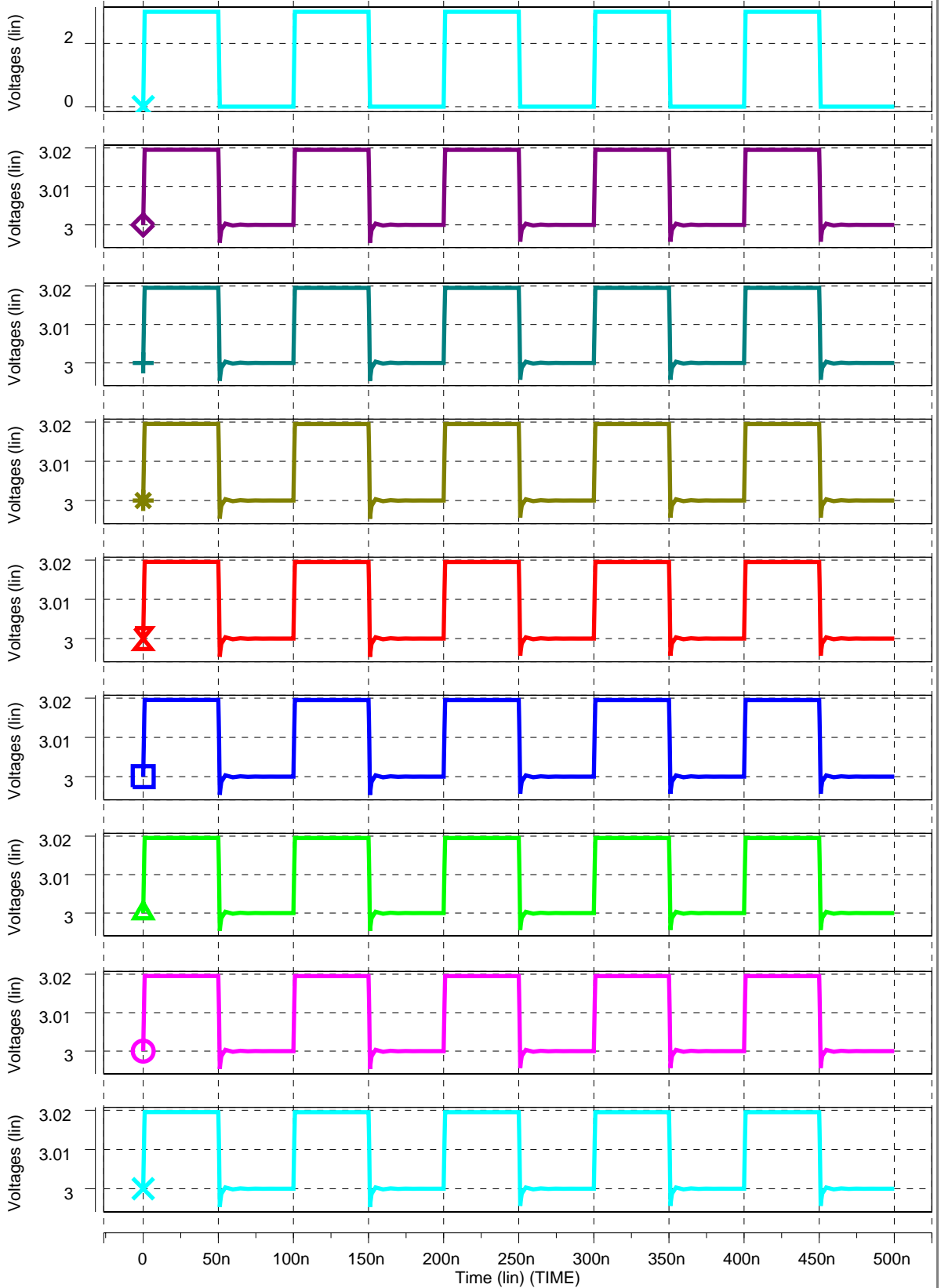

bus8sel_35

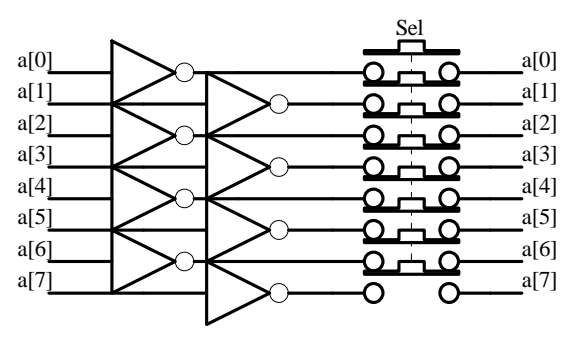
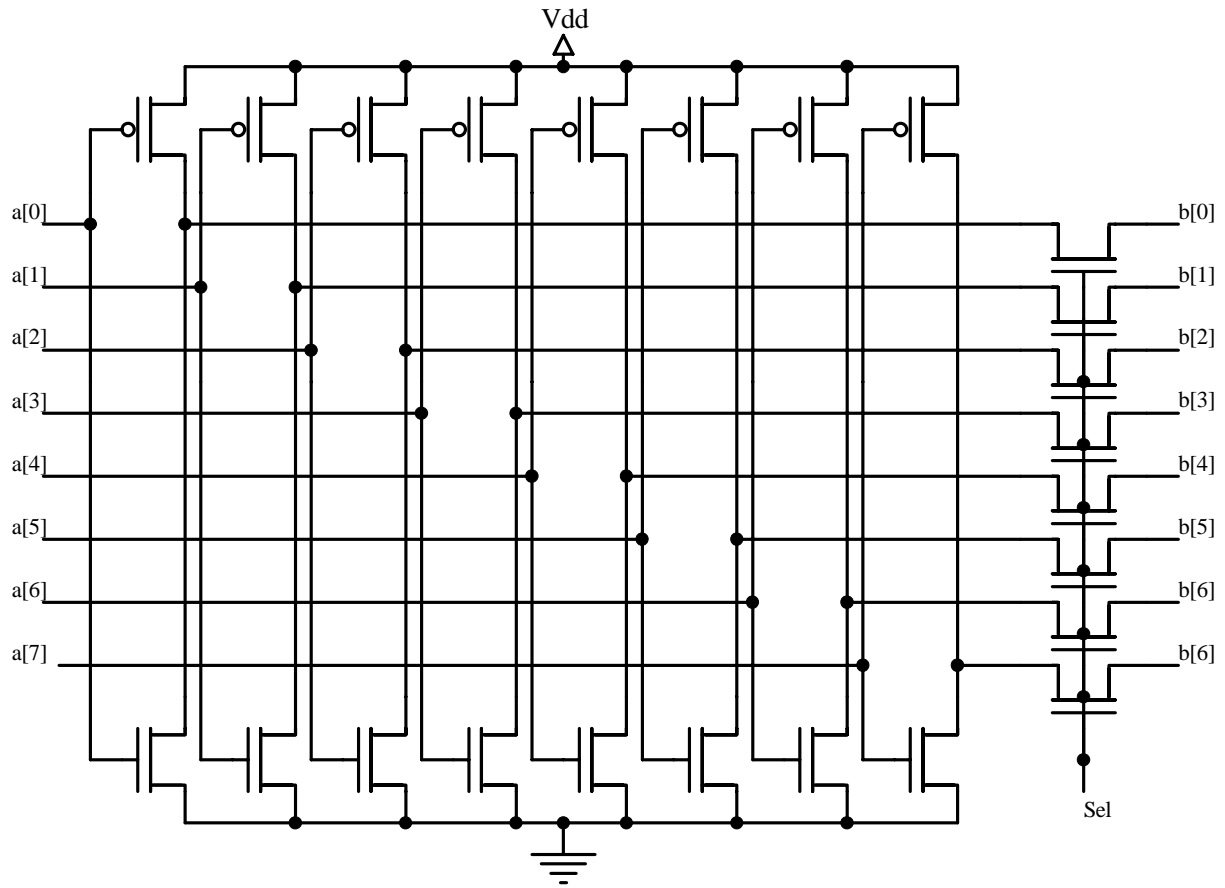

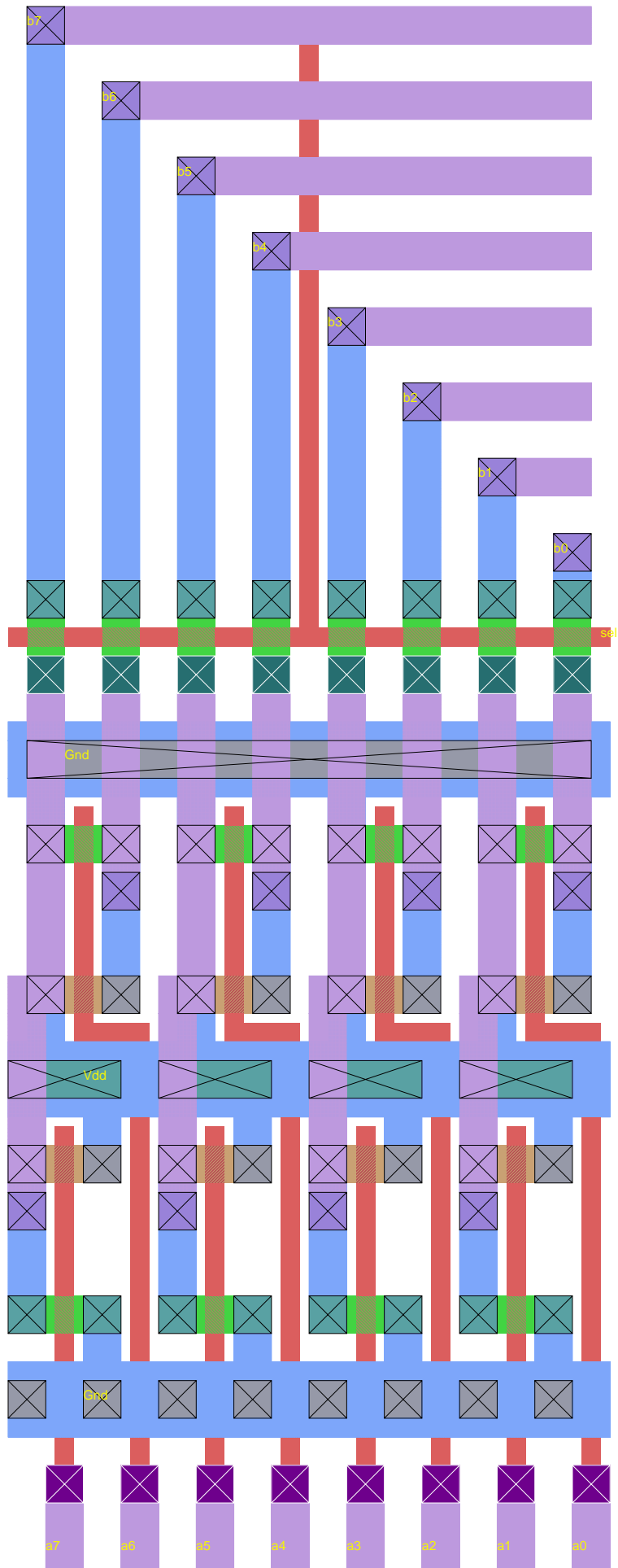

* hspice file created from bus8sel_35.ext - technology

| Wave | Symbol |
|--------------|--------|
| D0:A0:v(b7) | ✕ |
| D0:A0:v(b6) | ○ |
| D0:A0:v(b5) | △ |
| D0:A0:v(b4) | □ |
| D0:A0:v(b3) | ⊗ |
| D0:A0:v(b2) | * |
| D0:A0:v(b1) | + |
| D0:A0:v(b0) | ◇ |
| D0:A0:v(sel) | ✕ |
| D0:A0:v(a7) | ○ |
| D0:A0:v(a6) | △ |
| D0:A0:v(a5) | □ |
| D0:A0:v(a4) | ⊗ |
| D0:A0:v(a3) | * |
| D0:A0:v(a2) | + |
| D0:A0:v(a1) | ◇ |
| D0:A0:v(a0) | ✕ |

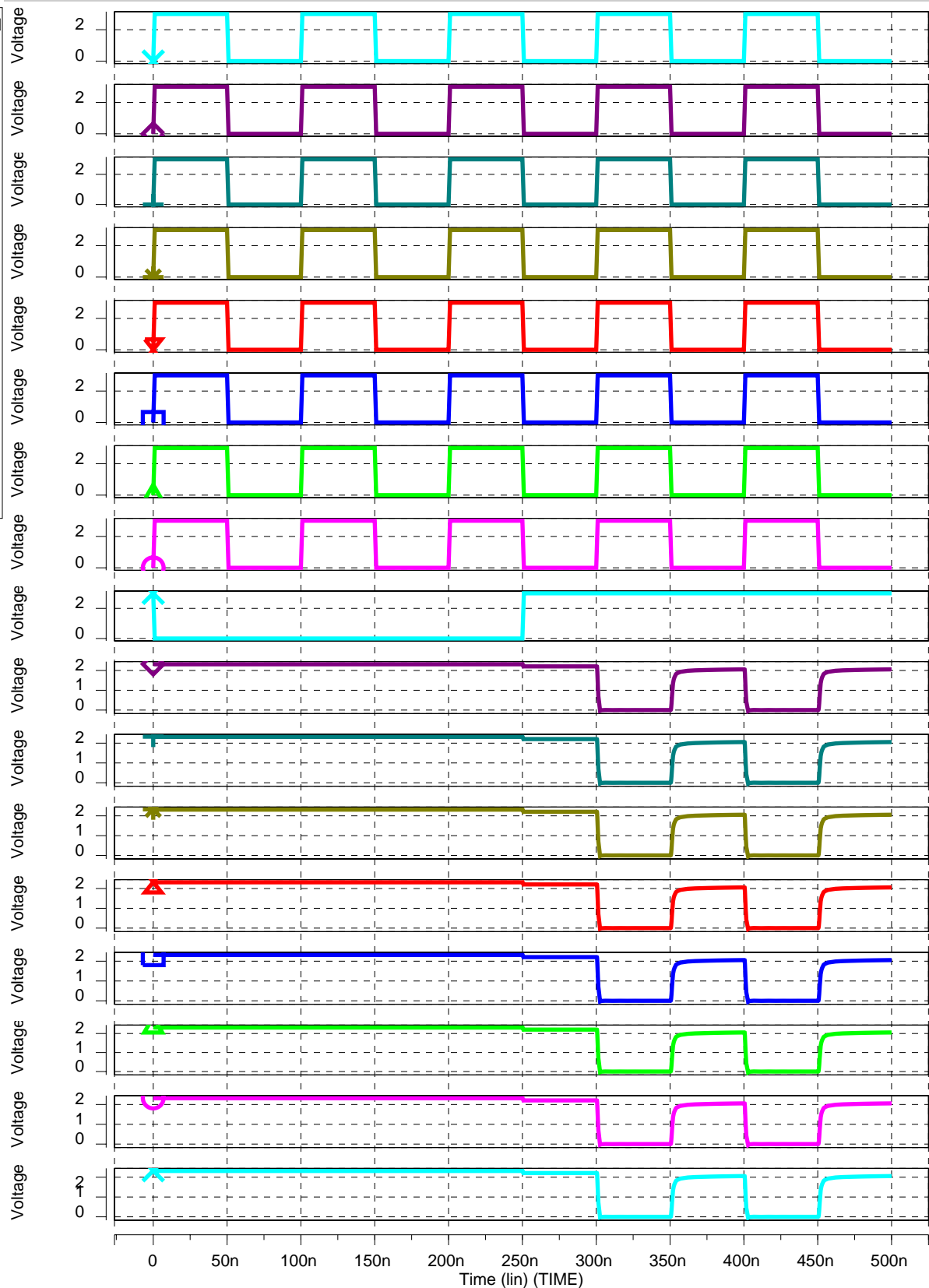

bus8_35

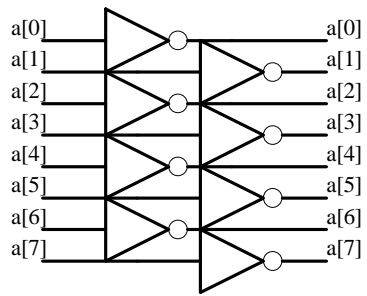
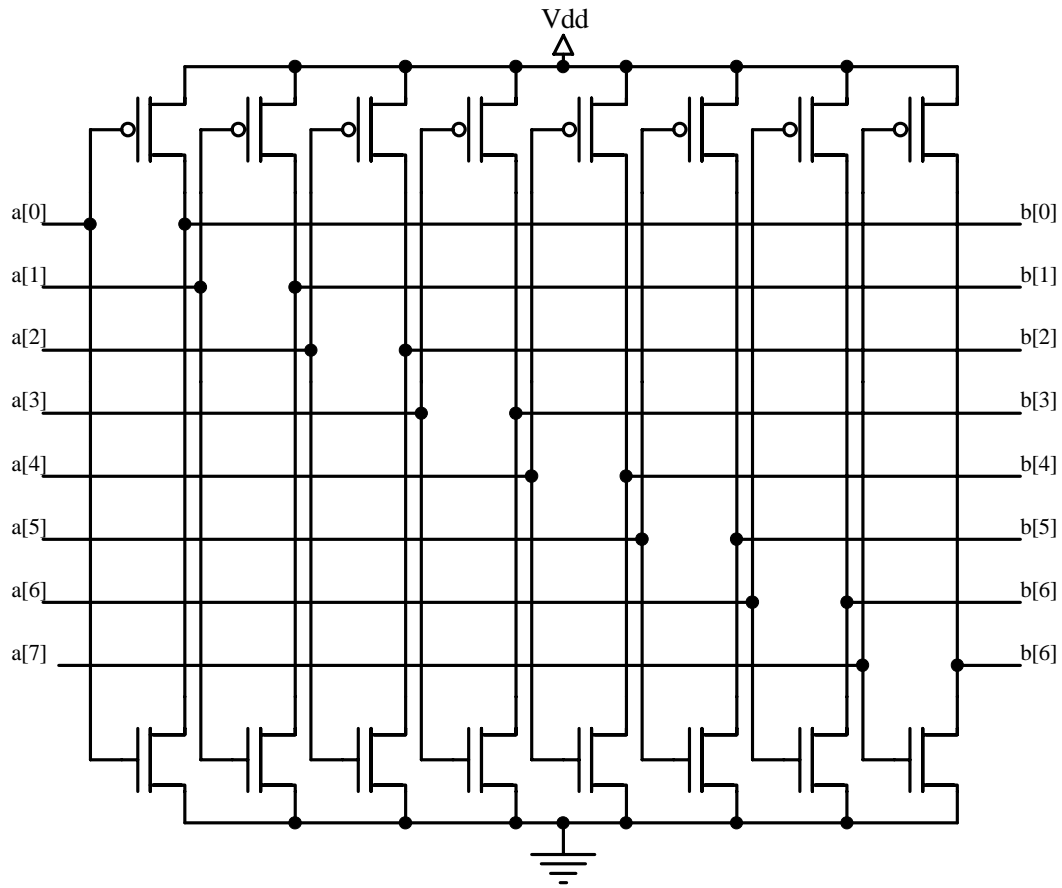

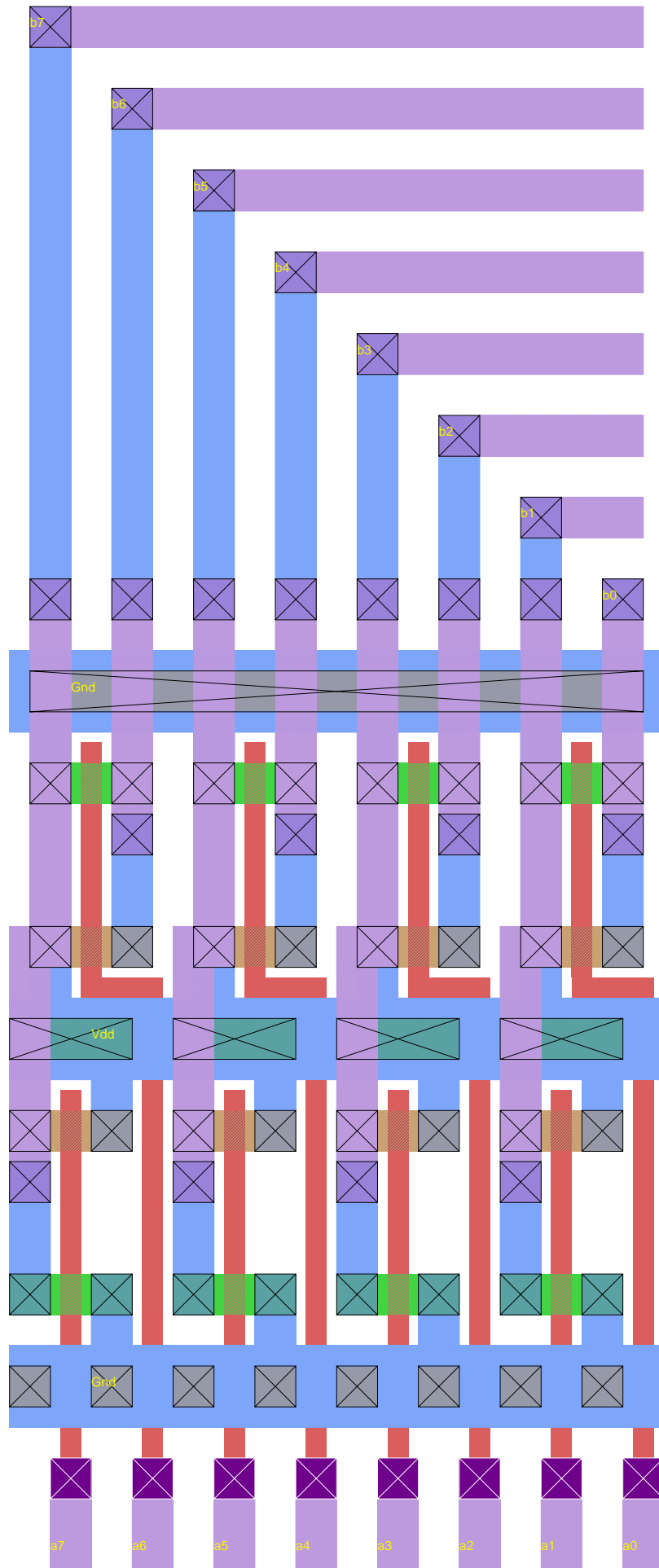

* hspice file created from bus8_35.ext - technology:

| Wave | Symbol |
|-------------|--------|
| D0:A0:v(b7) | ✕ |
| D0:A0:v(b6) | ○ |
| D0:A0:v(b5) | △ |
| D0:A0:v(b4) | □ |
| D0:A0:v(b3) | ⊗ |
| D0:A0:v(b2) | * |
| D0:A0:v(b1) | + |
| D0:A0:v(b0) | ◇ |
| D0:A0:v(a7) | ✕ |
| D0:A0:v(a6) | ○ |
| D0:A0:v(a5) | △ |
| D0:A0:v(a4) | □ |
| D0:A0:v(a3) | ⊗ |
| D0:A0:v(a2) | * |
| D0:A0:v(a1) | + |
| D0:A0:v(a0) | ◇ |

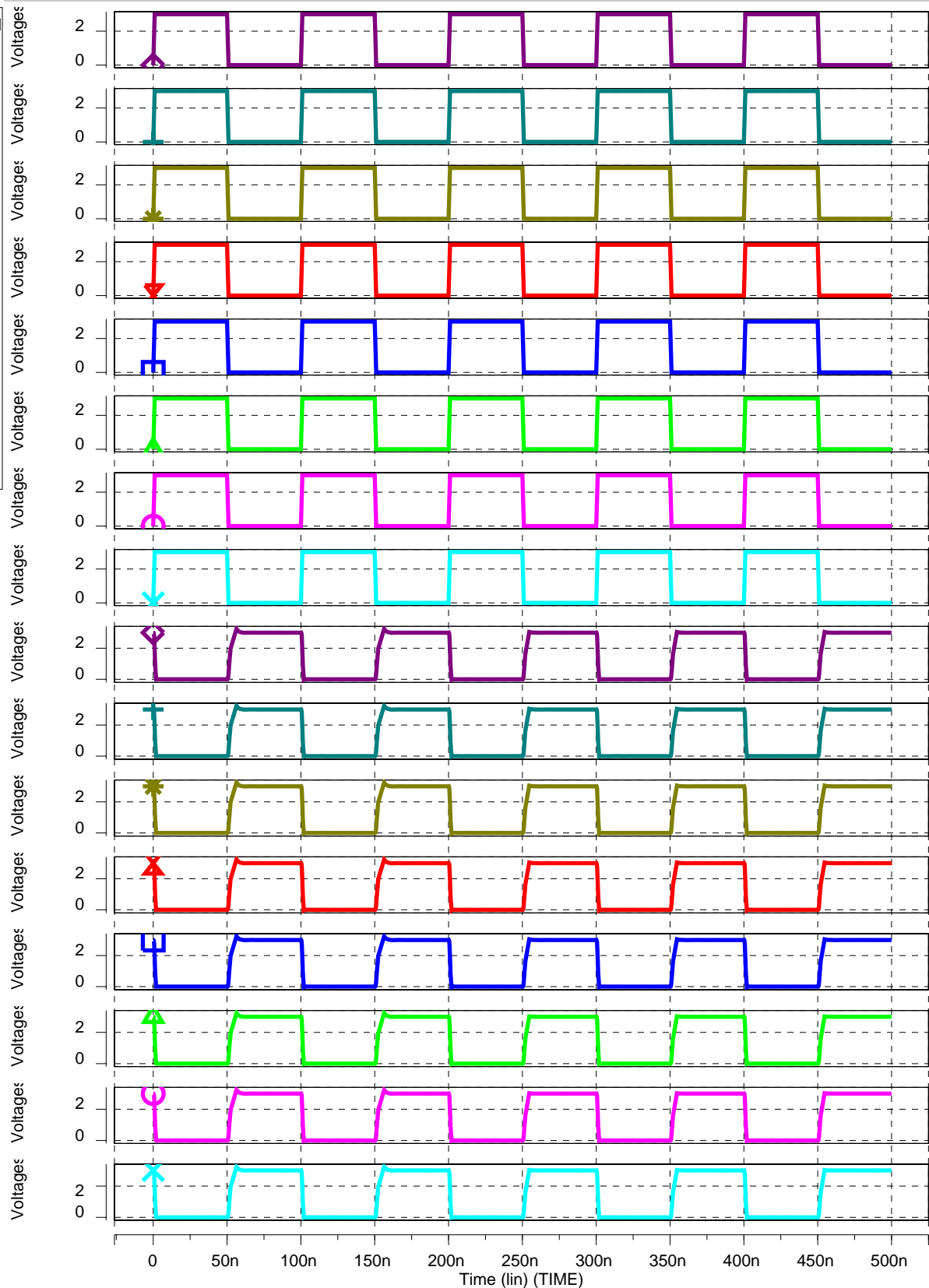

1

2

3

4

ROM array for the following binary information:

rd8x16_35

```

01001000
11001101
01010011
00001111
10100010
11111111
00010000
10101010
00101010
11001101
01010011
00001111
10100010
11111111
00010000
10101010

```

The Magic file for this ROM was created by the MATLAB routine: ROMD_35

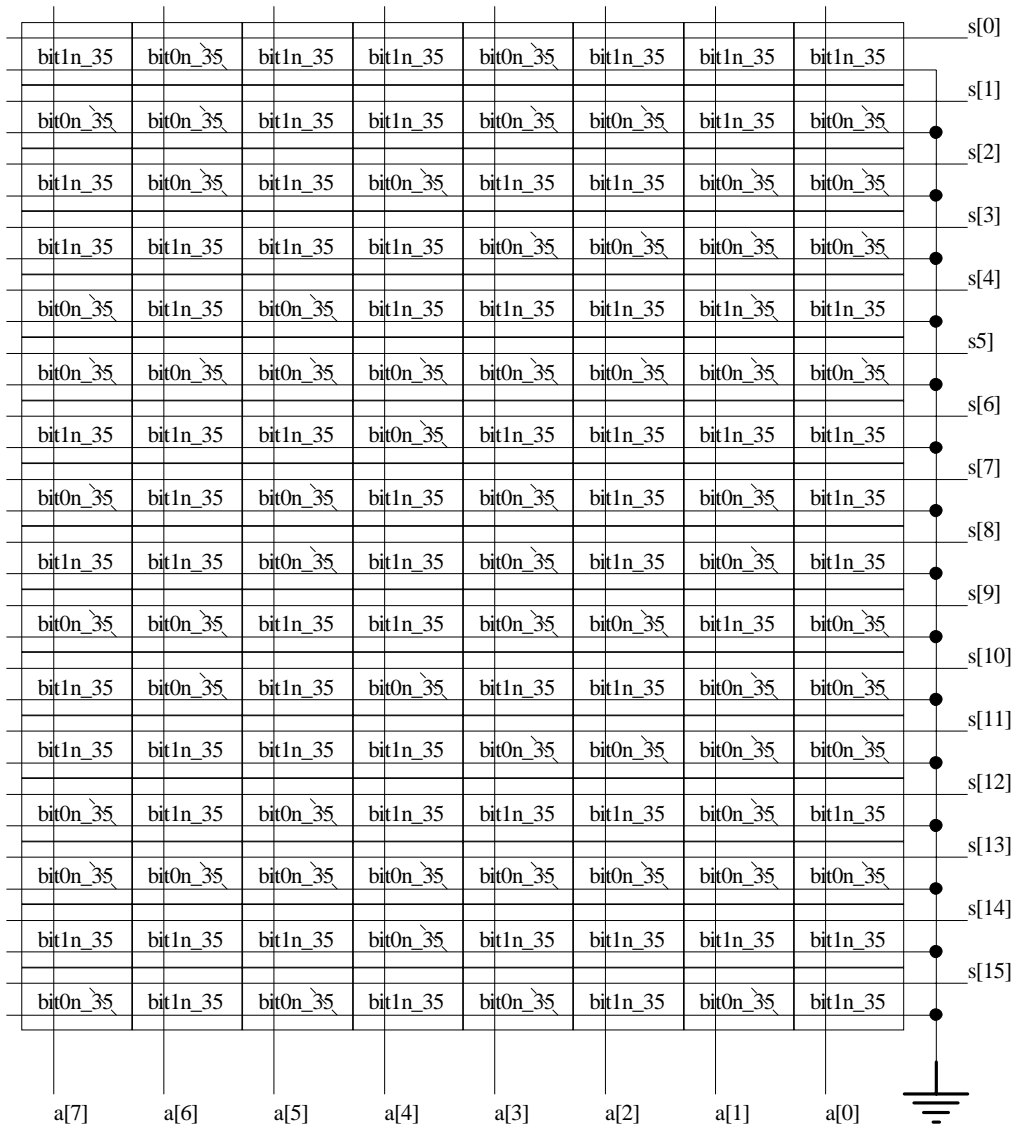

1

2

3

4

D

D

C

C

B

B

A

A

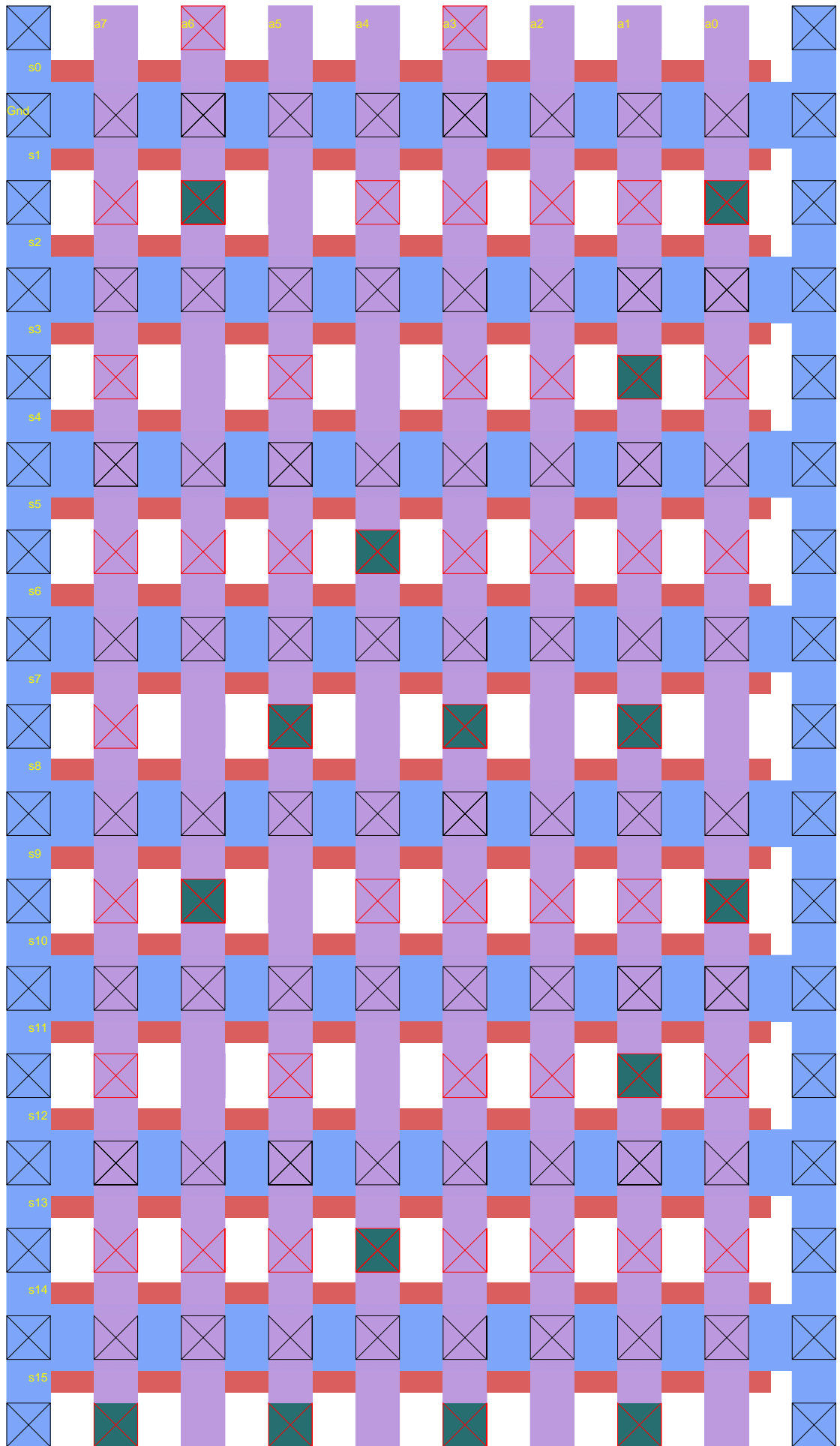

ROM array for the following binary information:

The Magic file for this ROM was created by the MATLAB routine: ROMS_35

rs8x16a_35

```

01001000
11001101
01010011
00001111
10100010
11111111
00010000
10101010
00101010
11001101
01010011
00001111
10100010
11111111
00010000
10101010

```

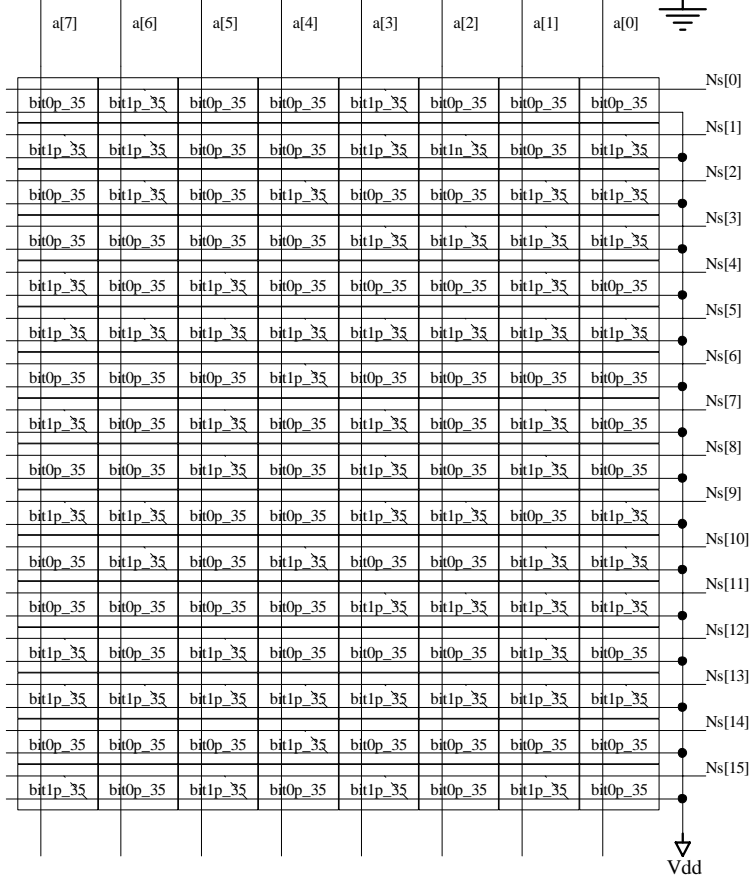
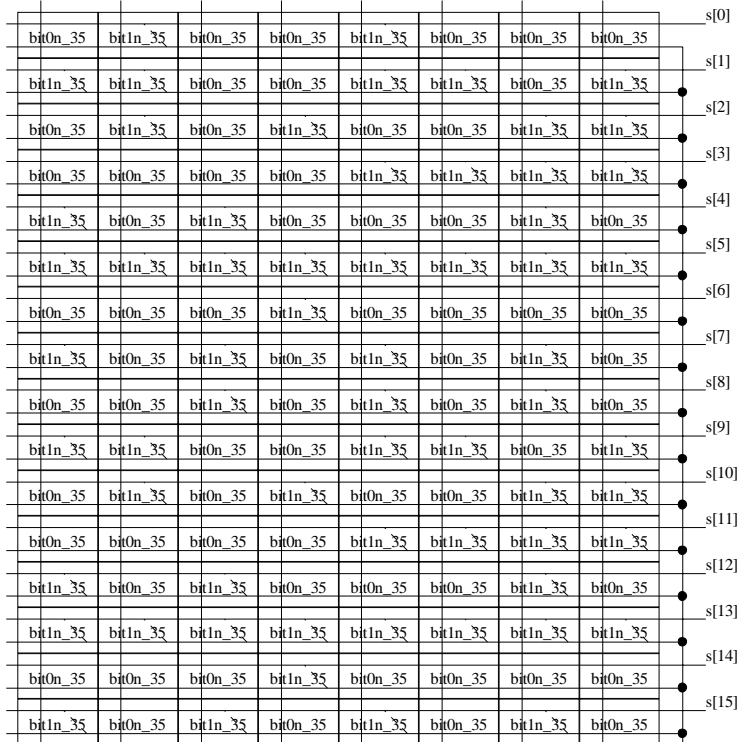

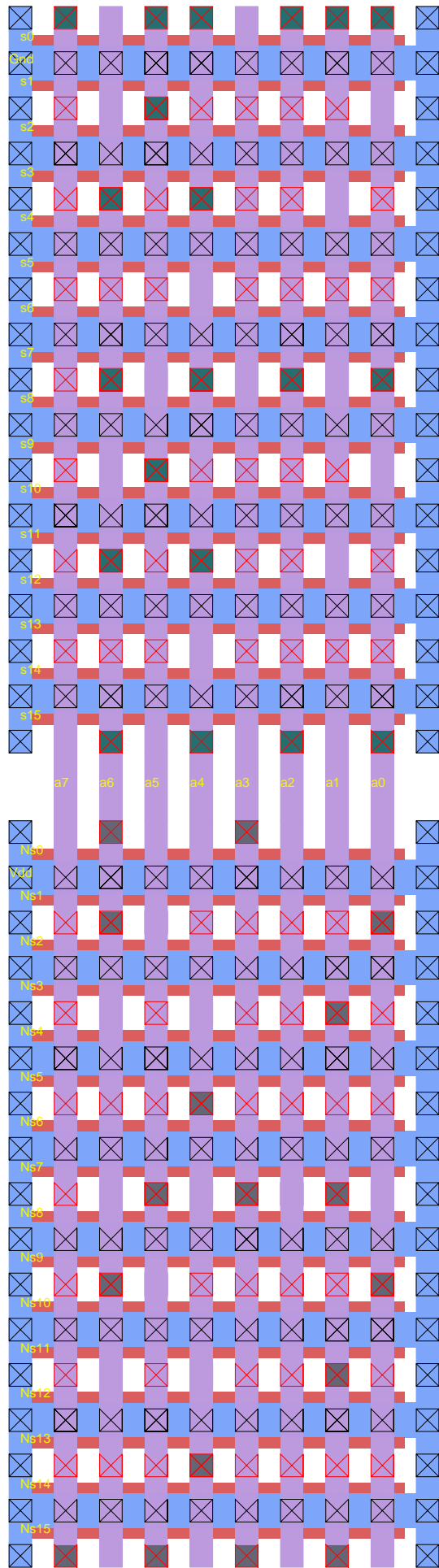

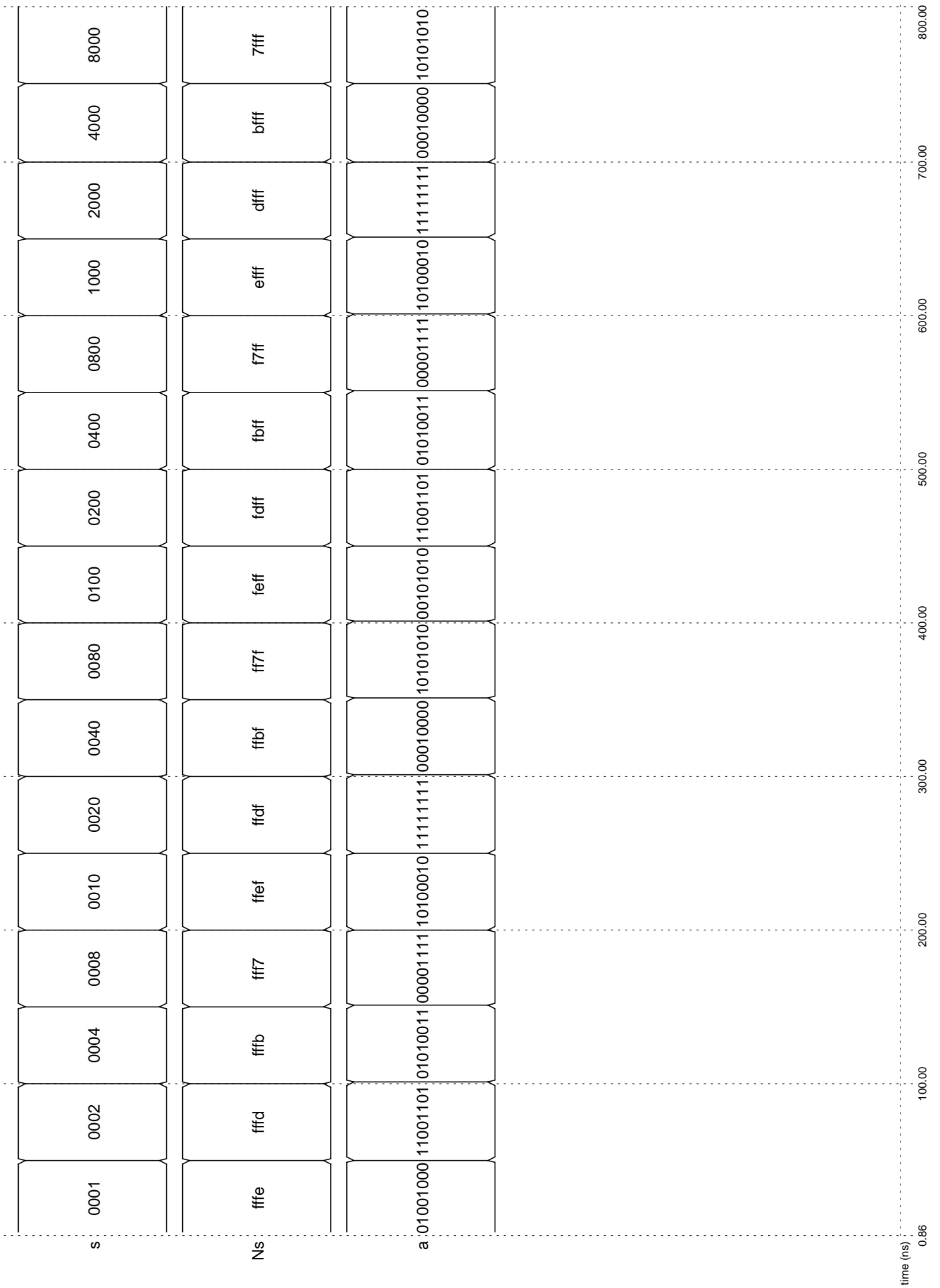

time (ns)

0.86

100.00

200.00

300.00

400.00

500.00

600.00

700.00

800.00

1

2

3

4

2pc1_35

2-Phase Clock Generator

D

D

C

C

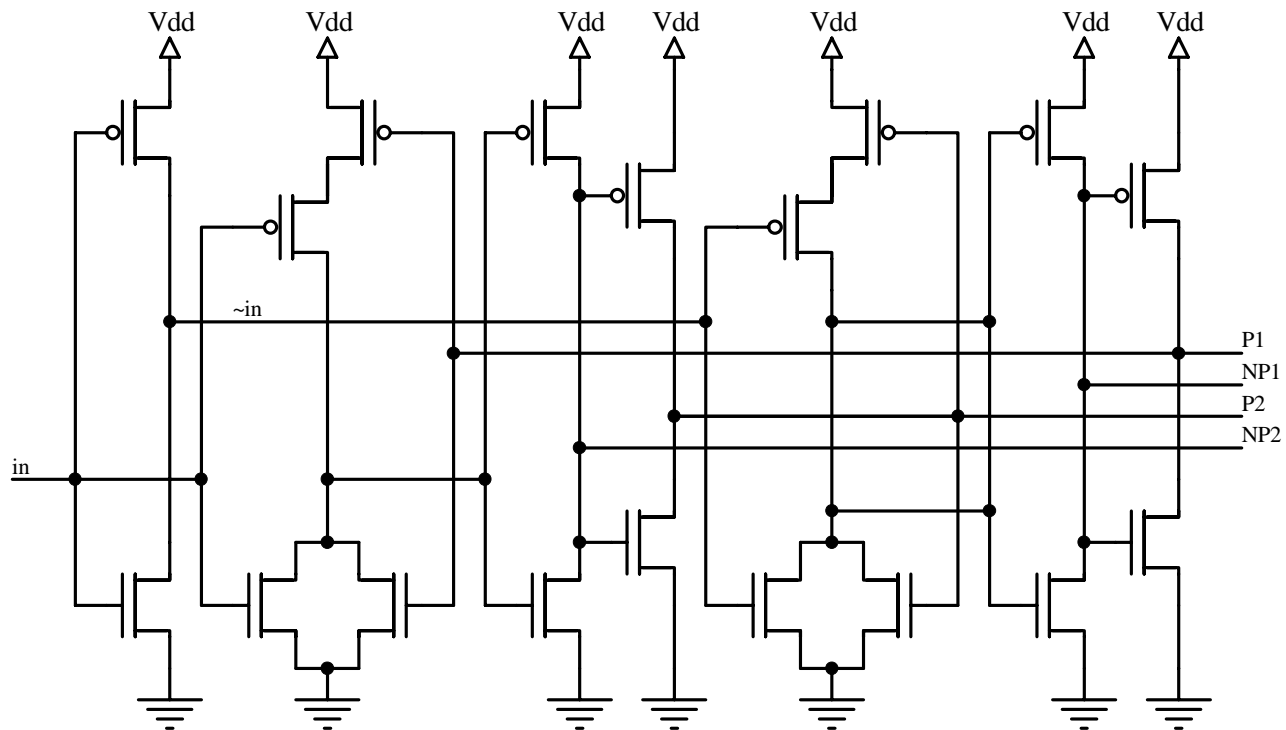

B

B

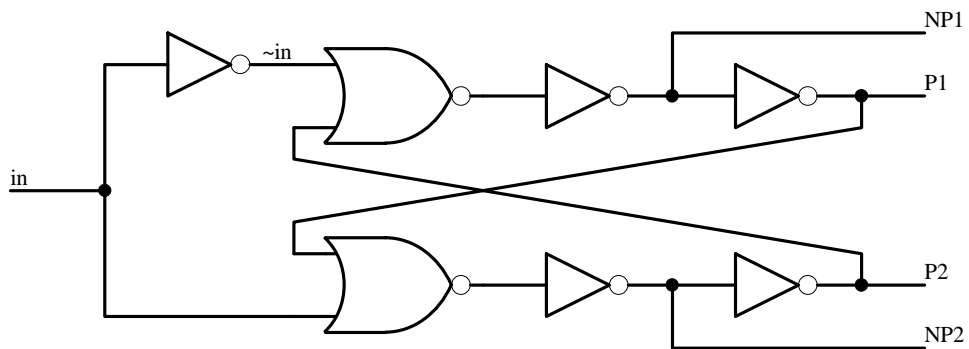

A

A

1

2

3

4

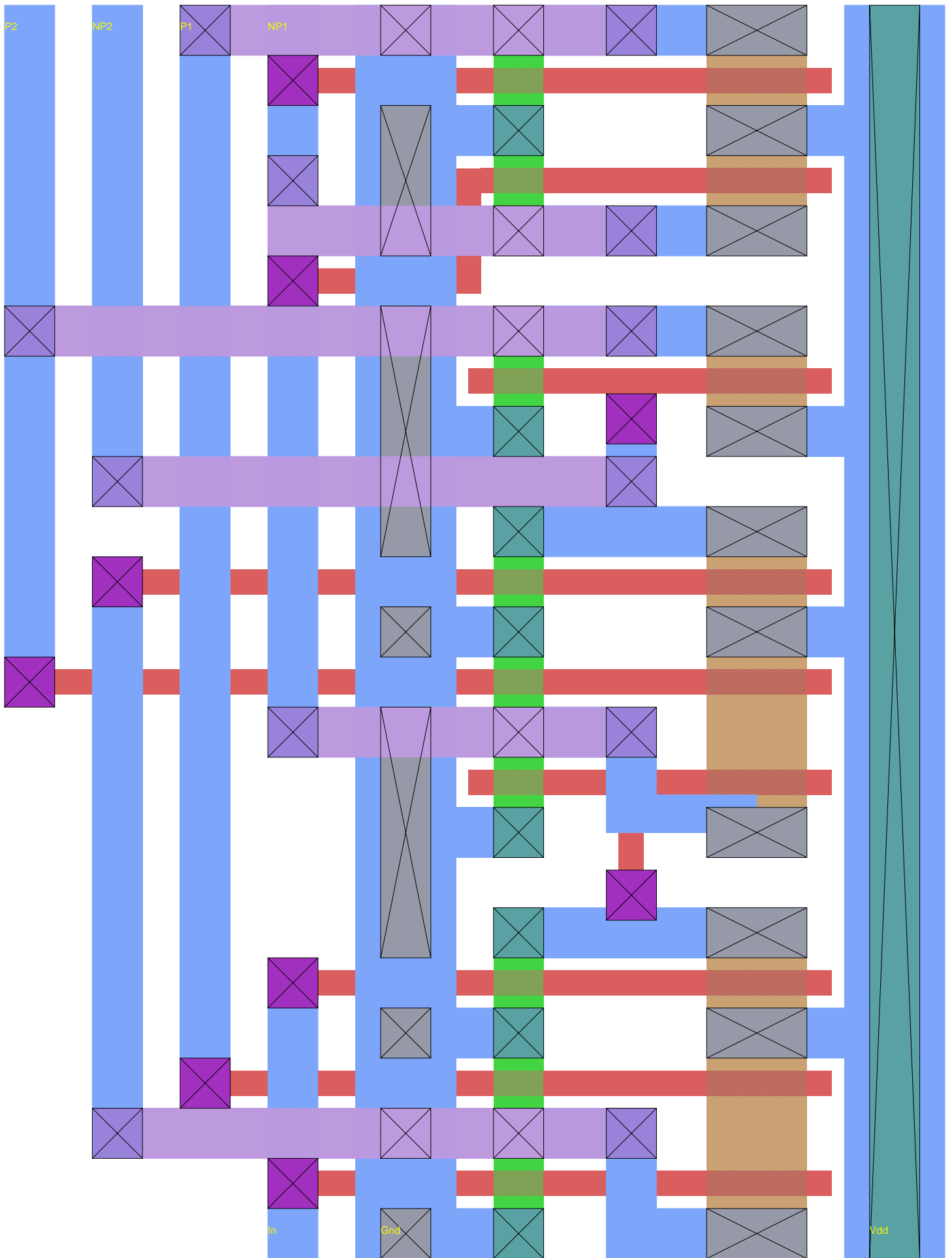

* hspice file created from 2pc1_35.ext - technology:

| Wave | Symbol |
|--------------|--------|
| D0:A0:v(np2) | ✕ |
| D0:A0:v(p2) | ○ |
| D0:A0:v(np1) | △ |
| D0:A0:v(p1) | □ |
| D0:A0:v(in) | ✕ |

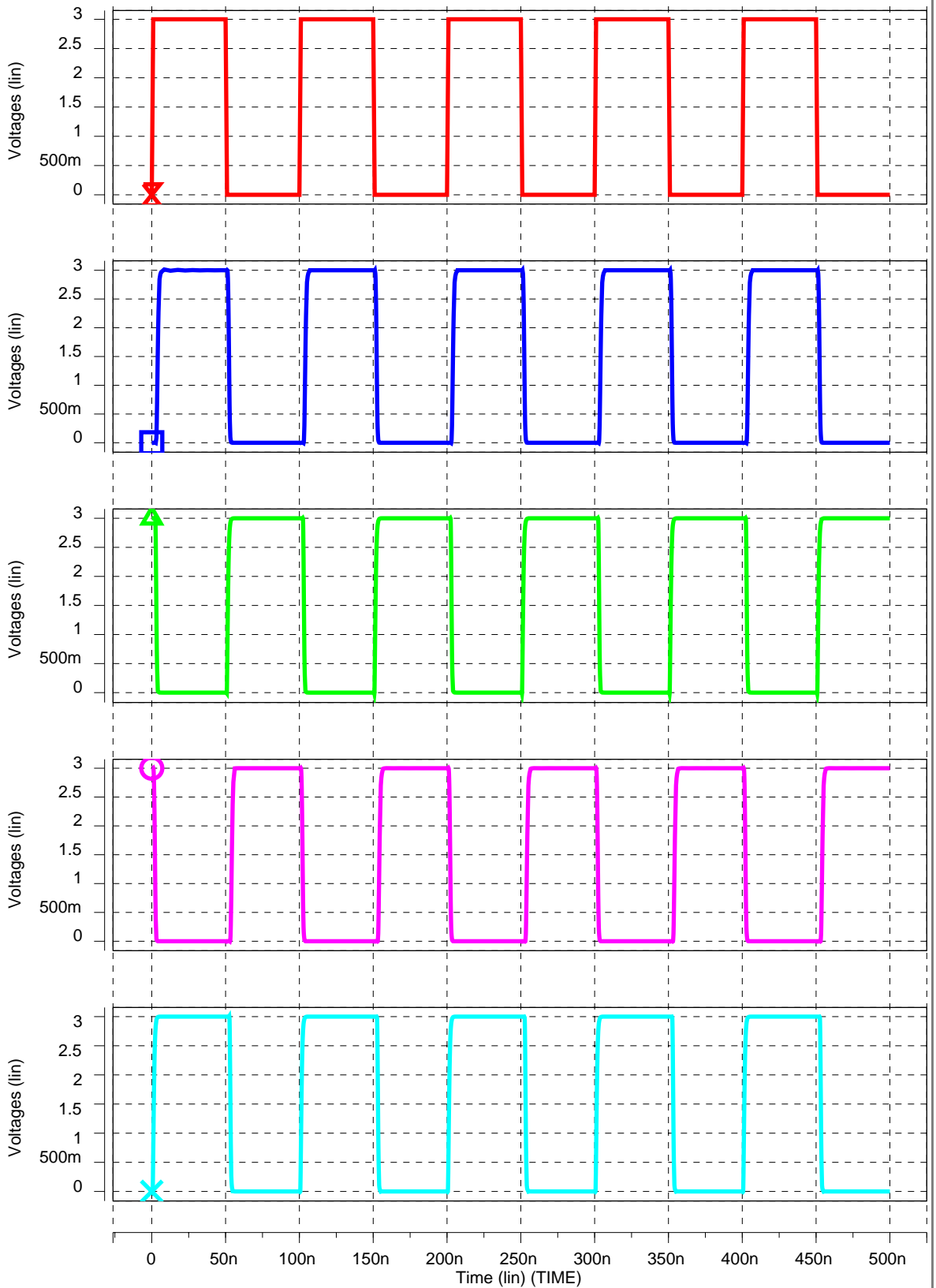

4bcounter_35

4-bit synchronous counter

2 phase clock generator

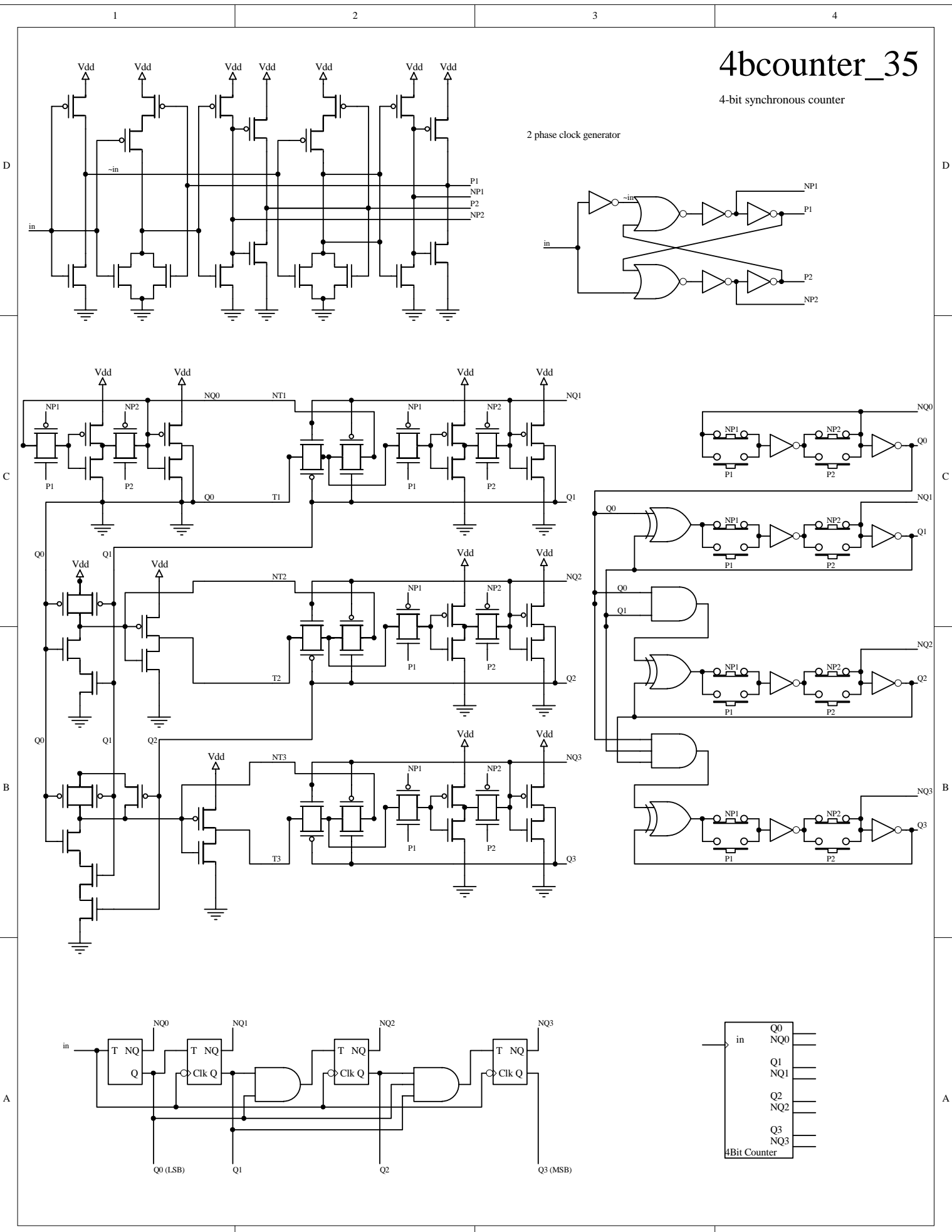

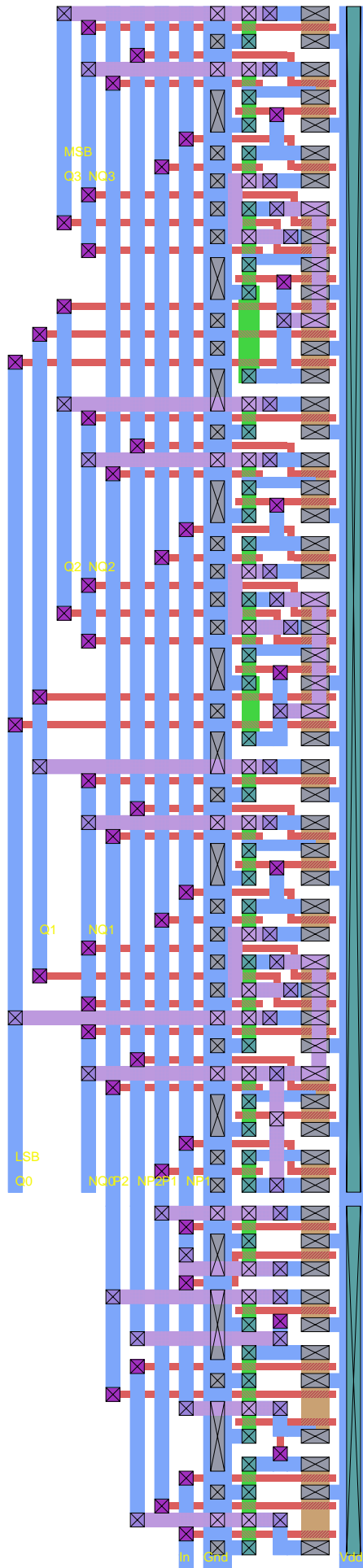

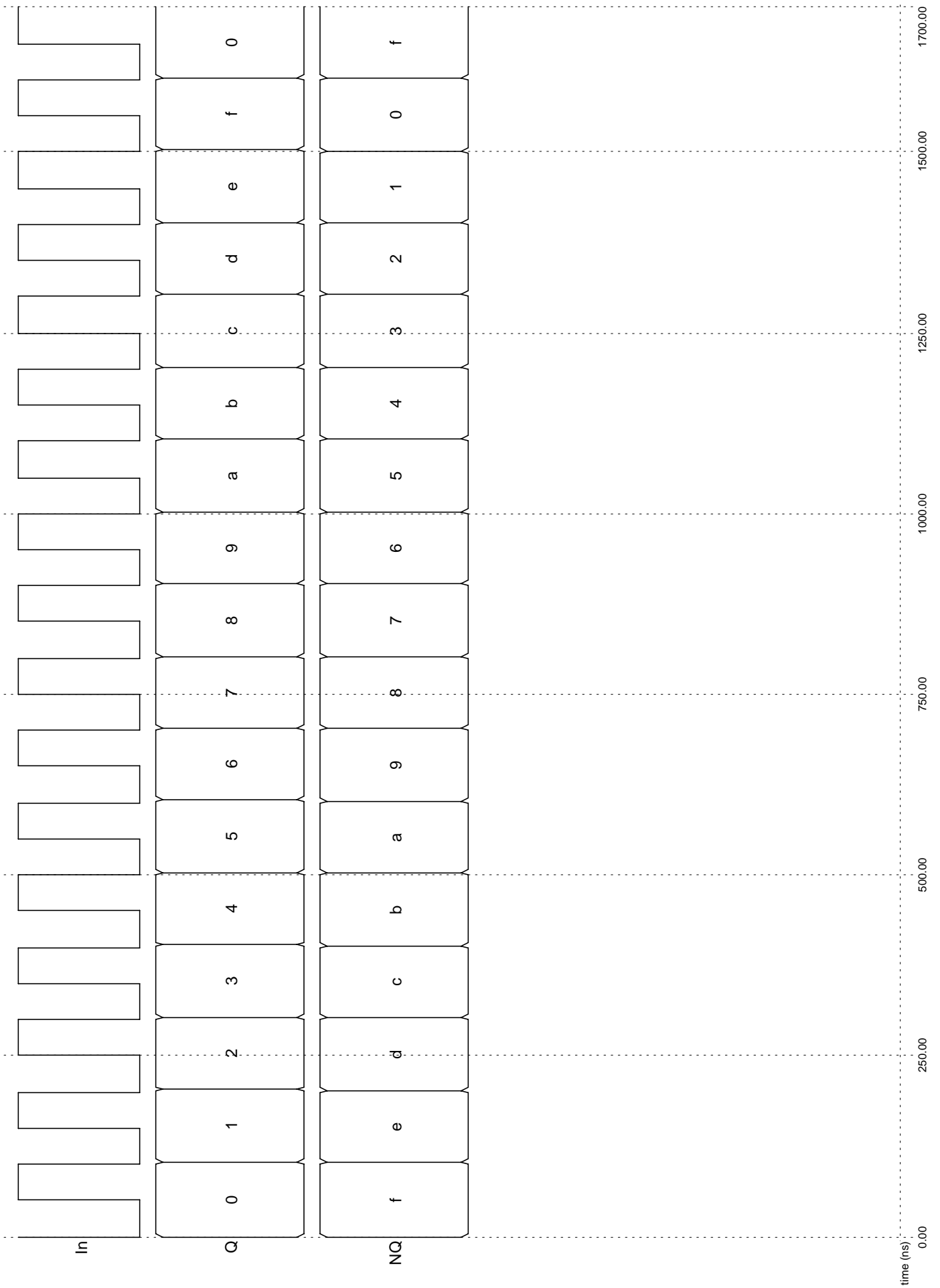

* hspice file created from 4bcounter_35.ext - technol

| Wave | Symbol |
|--------------|--------|
| D0:A0:v(nq3) | ✕ |
| D0:A0:v(nq2) | ⊖ |
| D0:A0:v(nq1) | △ |
| D0:A0:v(nq0) | ⊞ |
| D0:A0:v(q3) | ⊗ |
| D0:A0:v(q2) | ⋆ |
| D0:A0:v(q1) | + |
| D0:A0:v(q0) | ◇ |
| D0:A0:v(in) | ✕ |

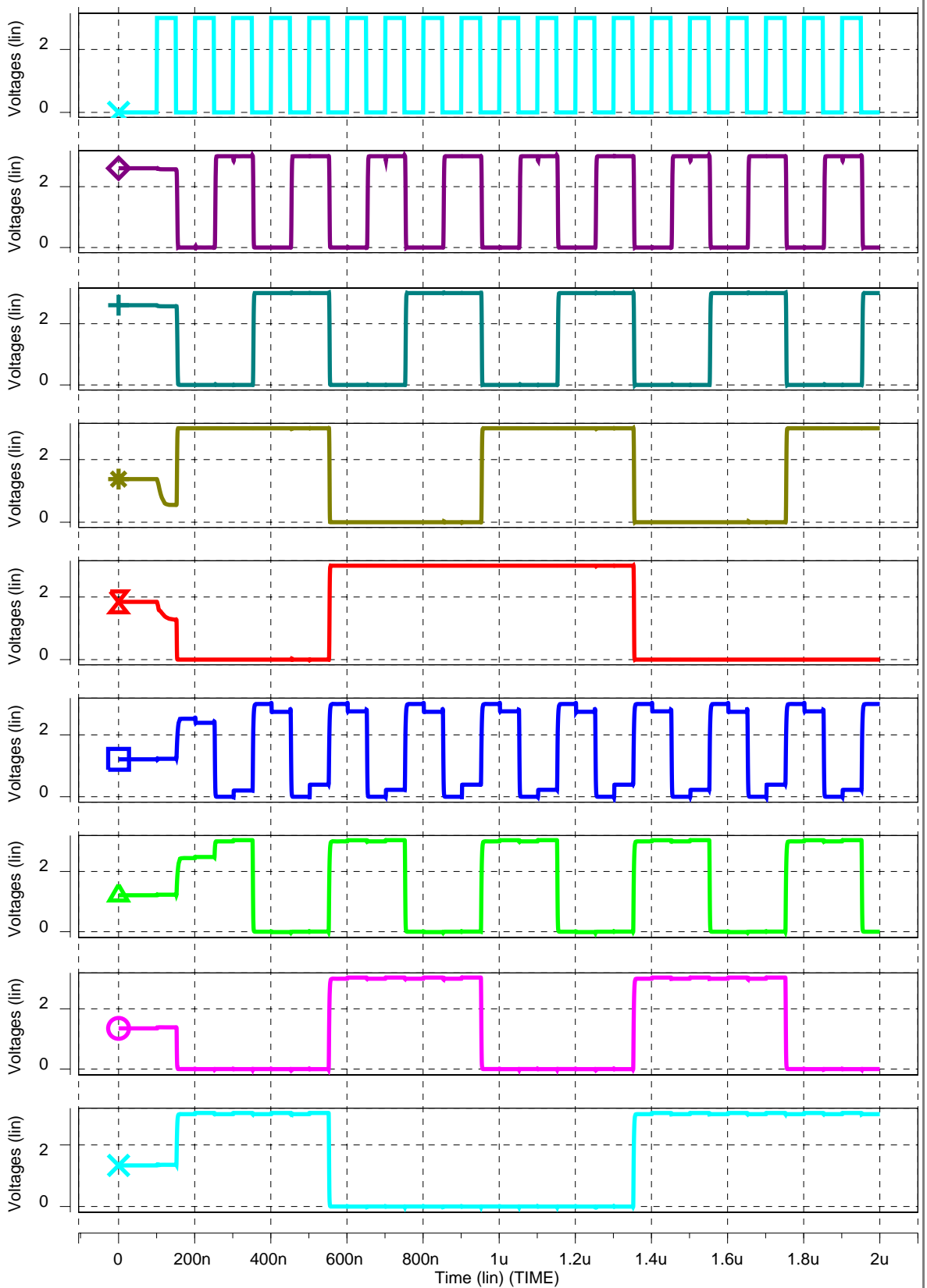

mux2to1_35

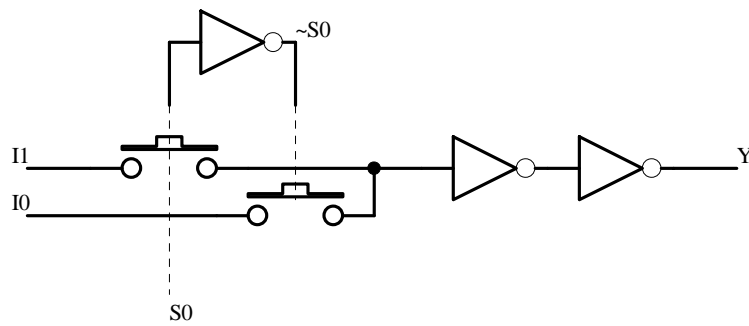
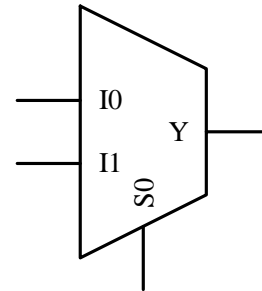
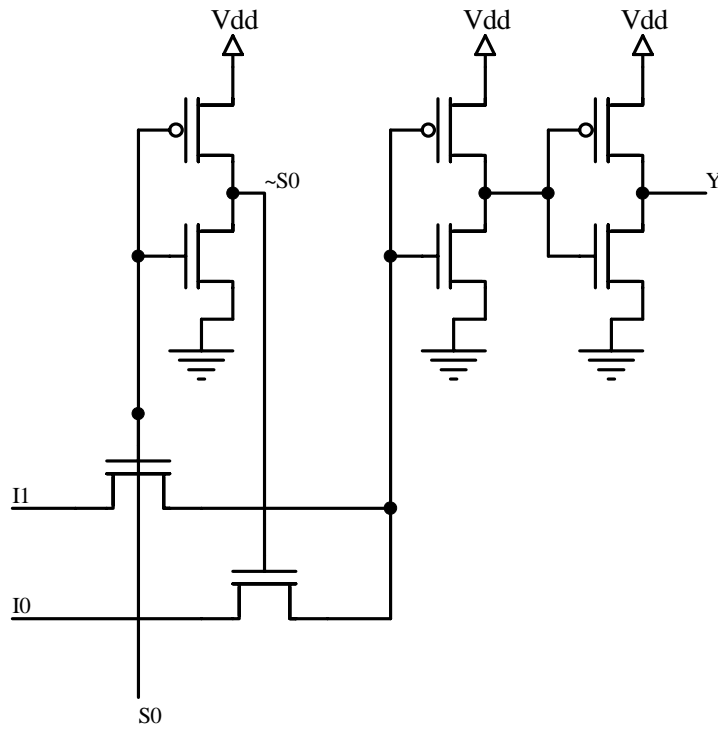

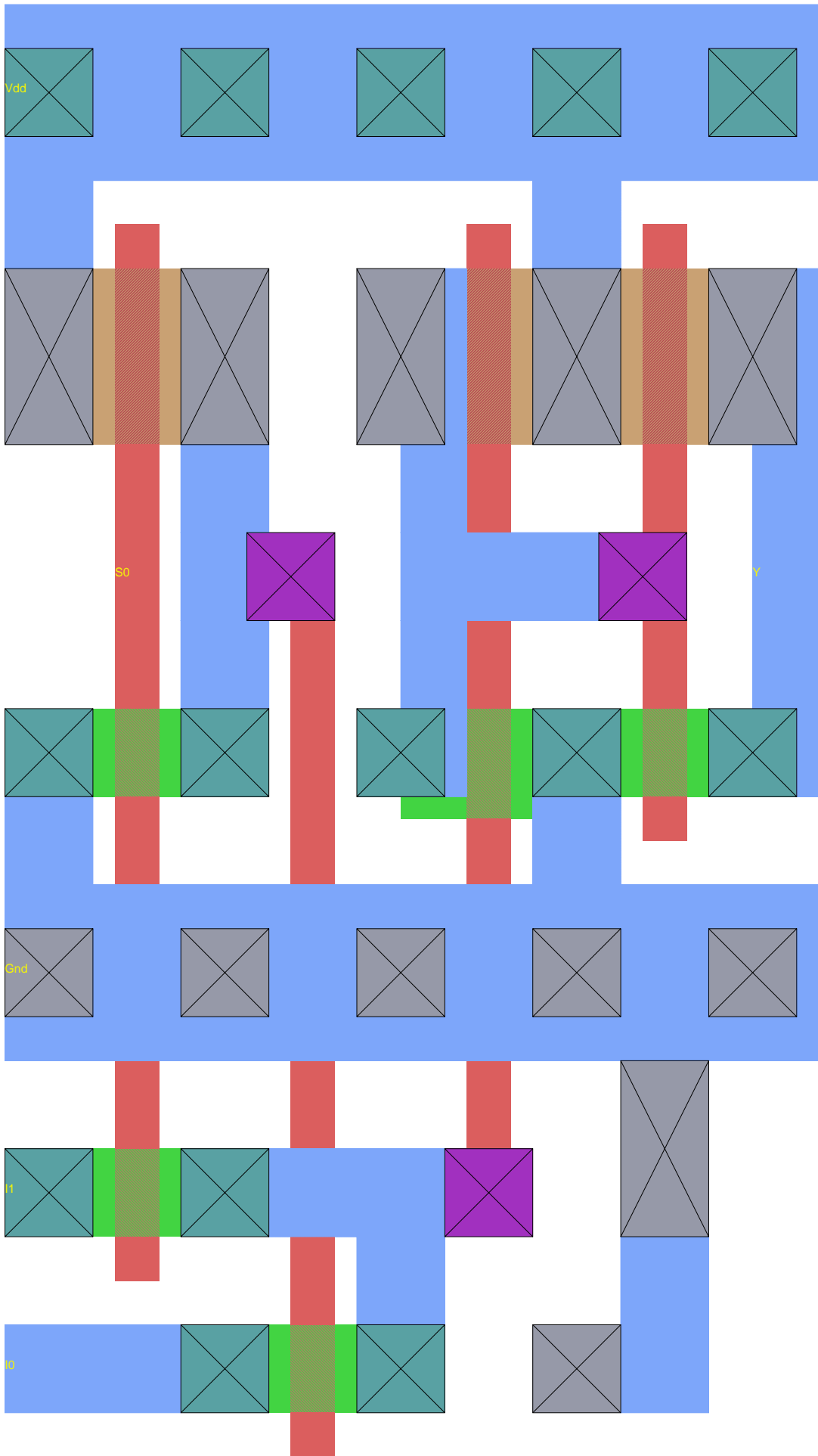

* hspice file created from mux2to1_35.ext - technology

| Wave | Symbol |
|-------------|--------|
| D0:A0:v(y) | X |
| D0:A0:v(i1) | ○ |
| D0:A0:v(i0) | △ |
| D0:A0:v(s0) | □ |

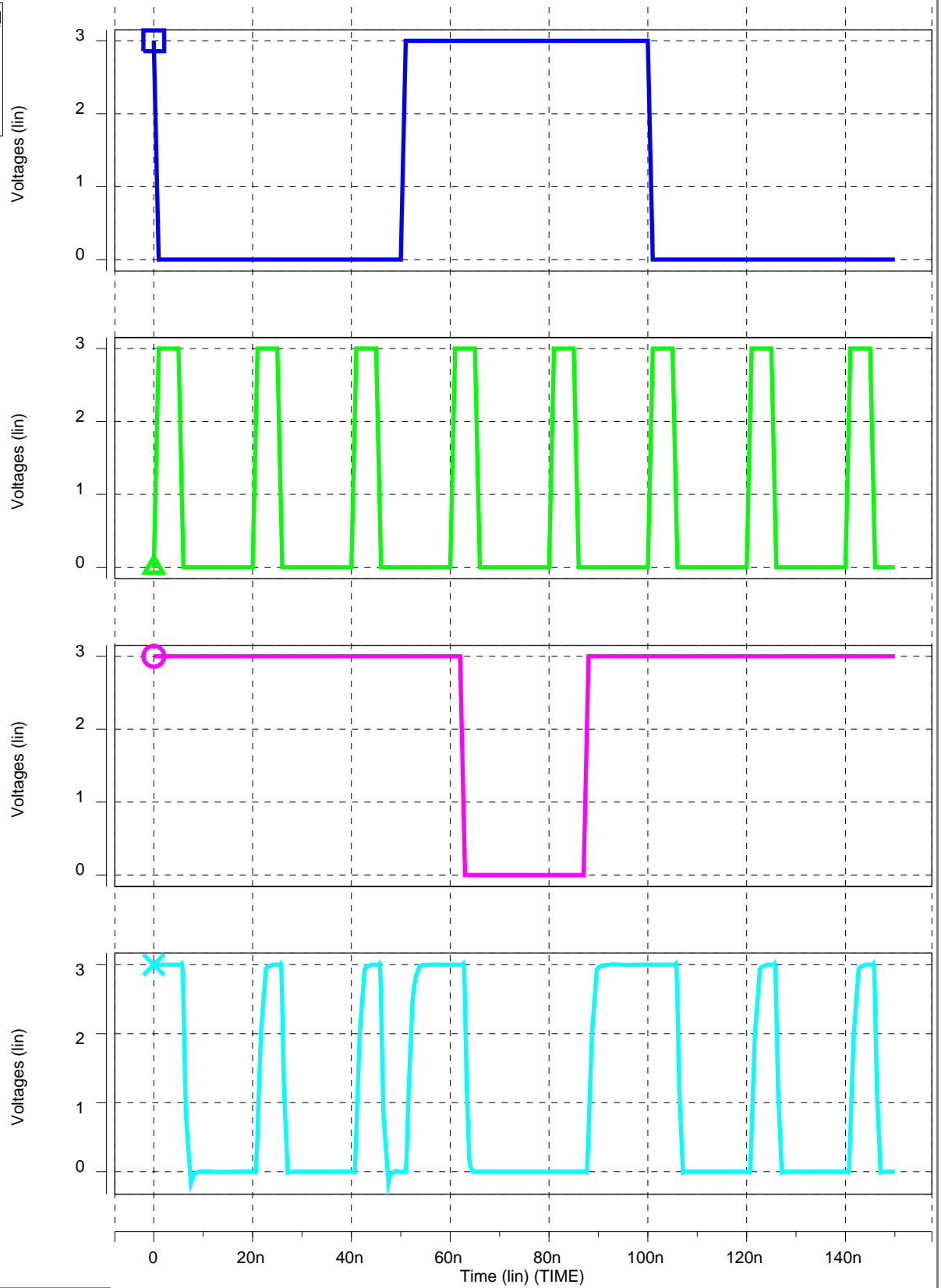

1

2

3

4

D

D

mux2to1a_35

C

C

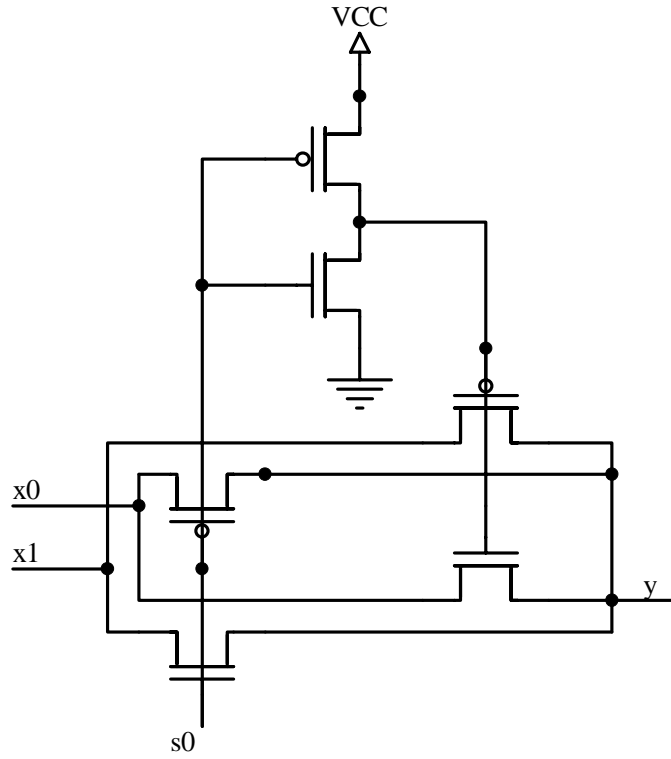

B

B

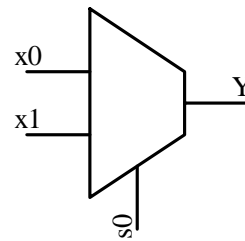
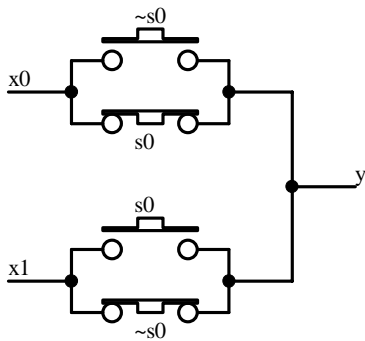
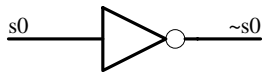

A

A

1

2

3

4

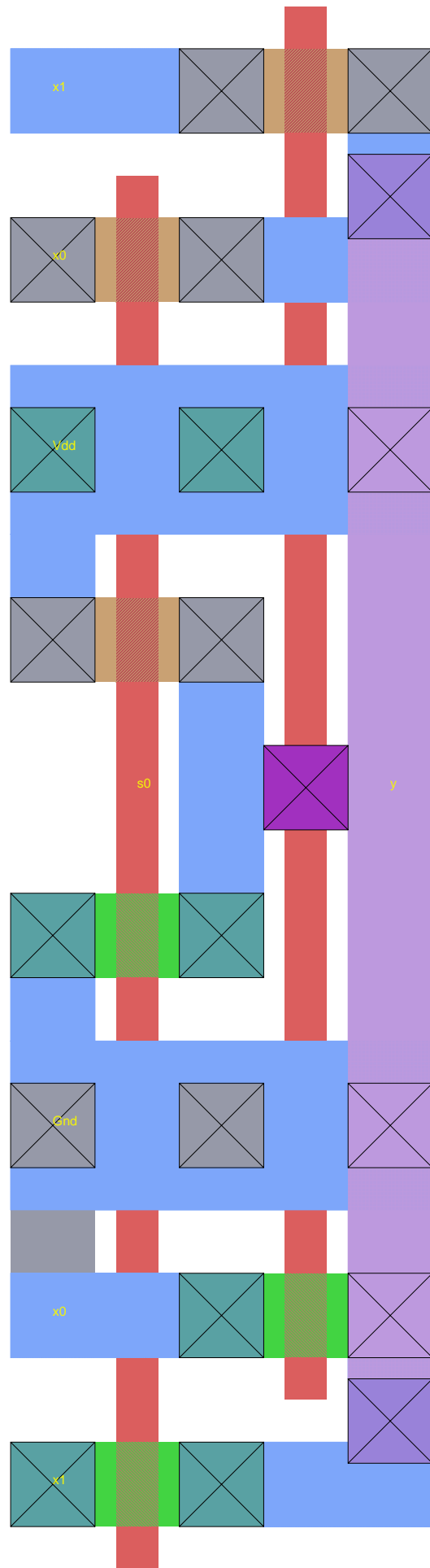

* hspice file created from mux2tola_35.ext - technolog

| Wave | Symbol |
|-------------|--------|
| D0:A0:v(y) | X |
| D0:A0:v(x1) | ○ |
| D0:A0:v(x0) | △ |
| D0:A0:v(s0) | □ |

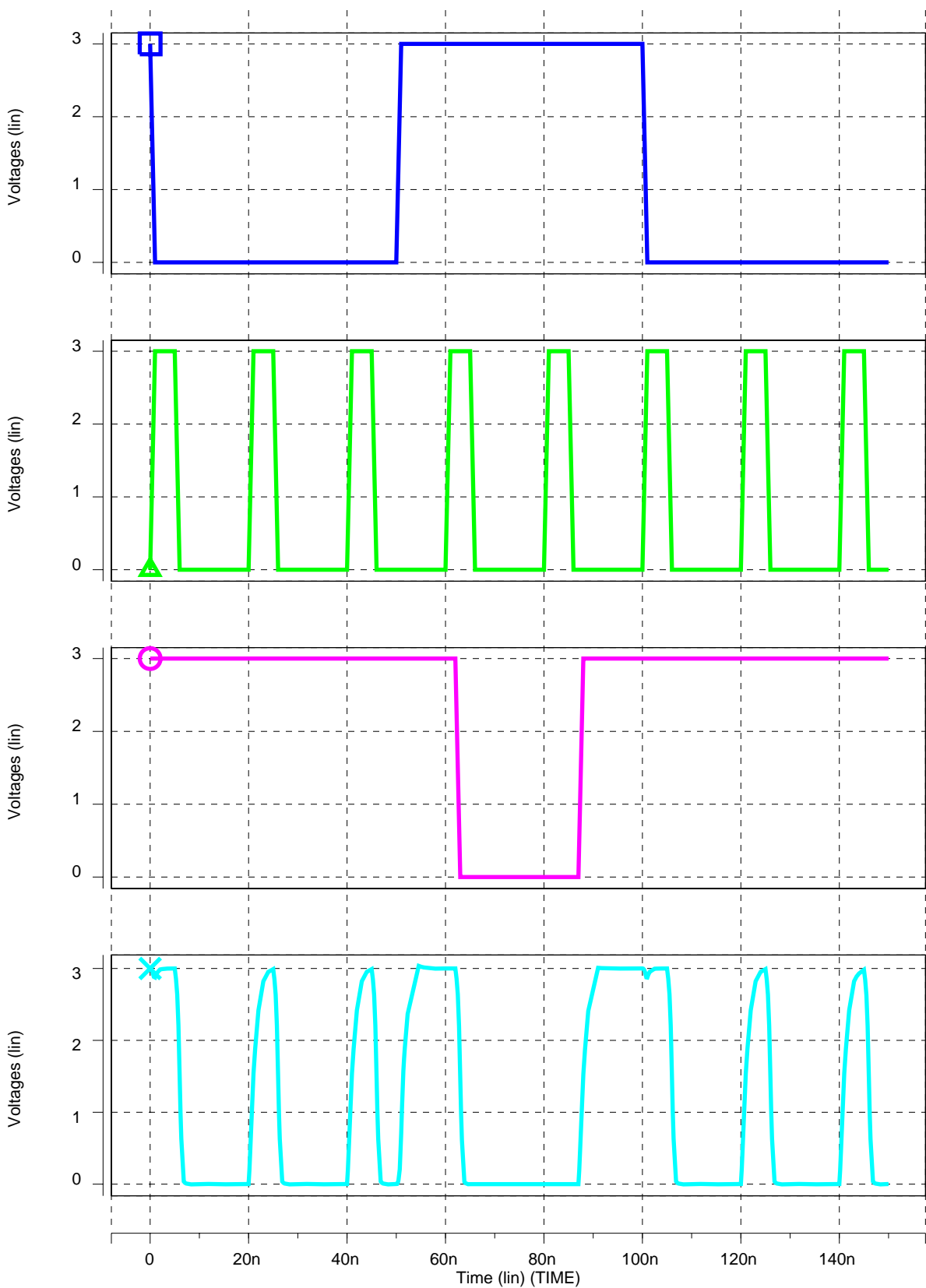

mux4to1_35

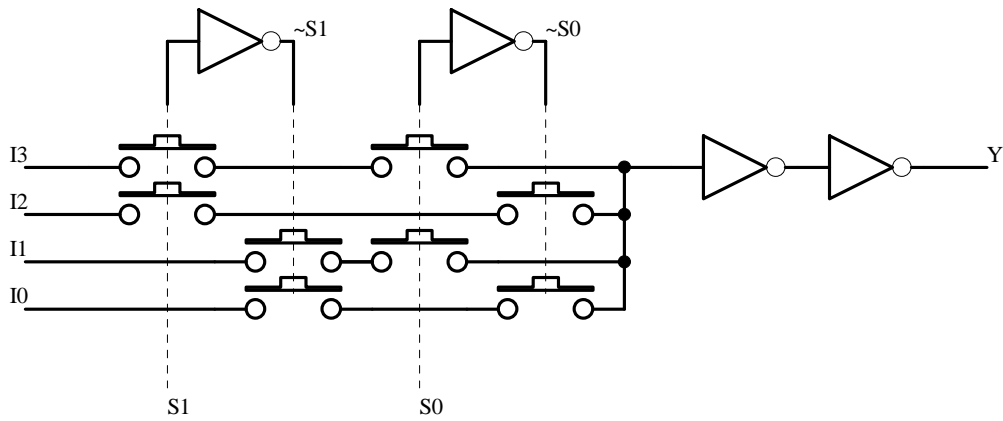
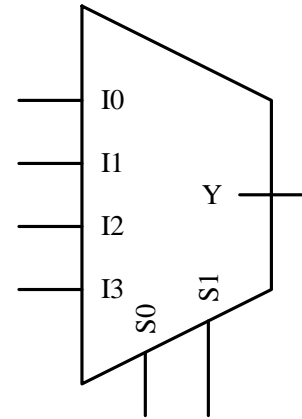
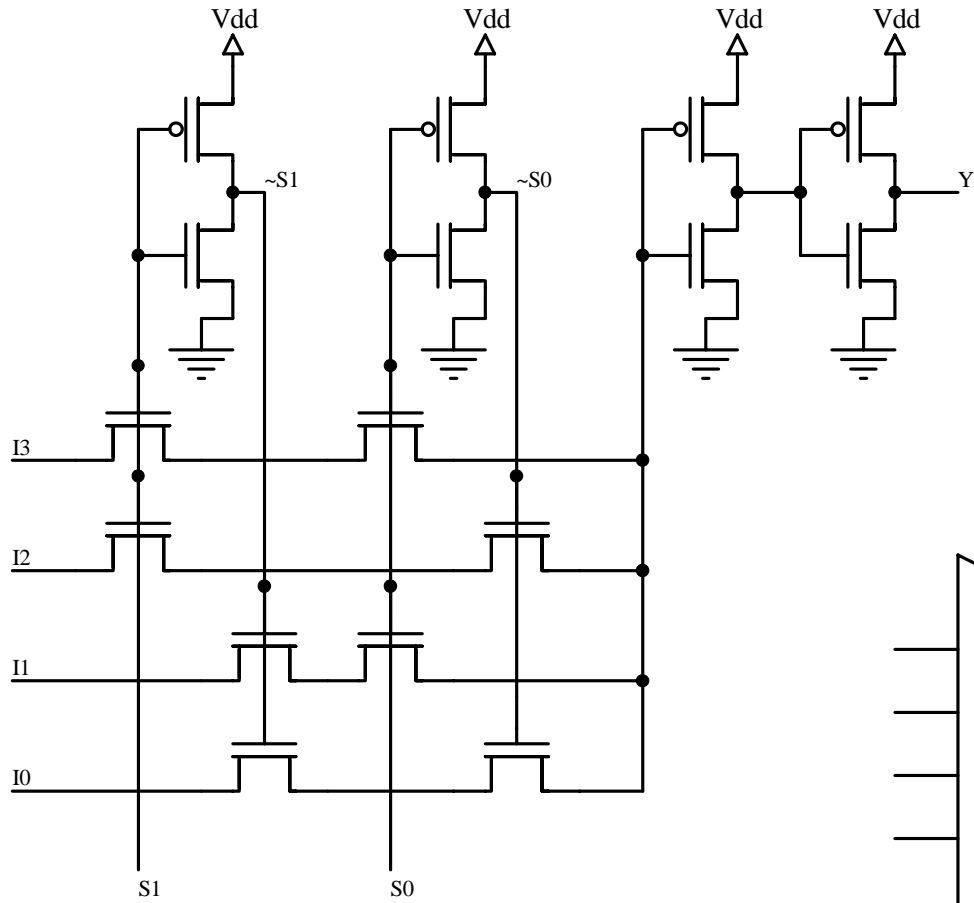

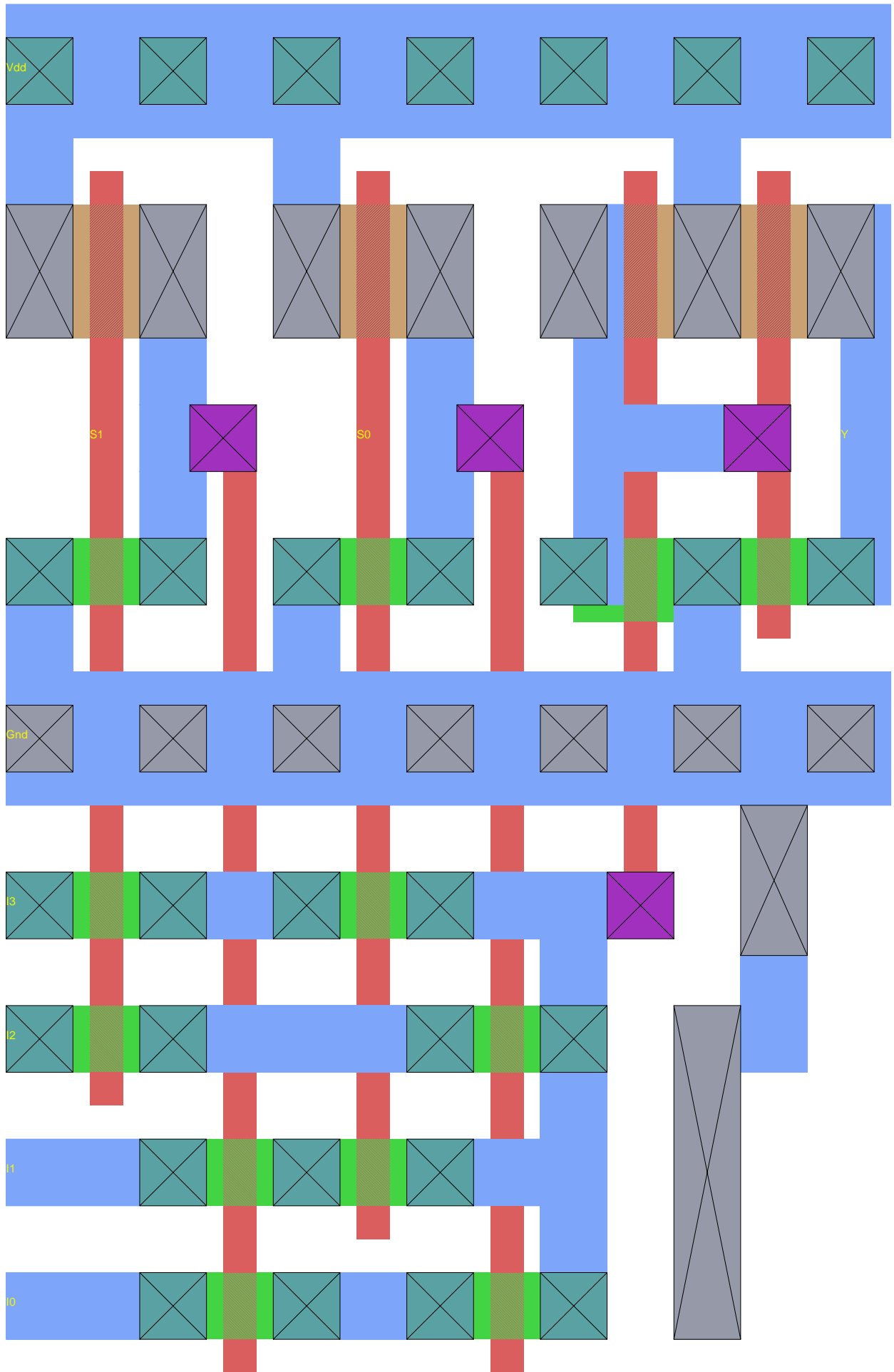

* hspice file created from mux4to1_35.ext - technology

| Wave | Symbol |
|-------------|--------|
| D0:A0:v(y) | X |
| D0:A0:v(i3) | o |
| D0:A0:v(i2) | △ |
| D0:A0:v(i1) | □ |
| D0:A0:v(i0) | × |
| D0:A0:v(s1) | * |
| D0:A0:v(s0) | + |

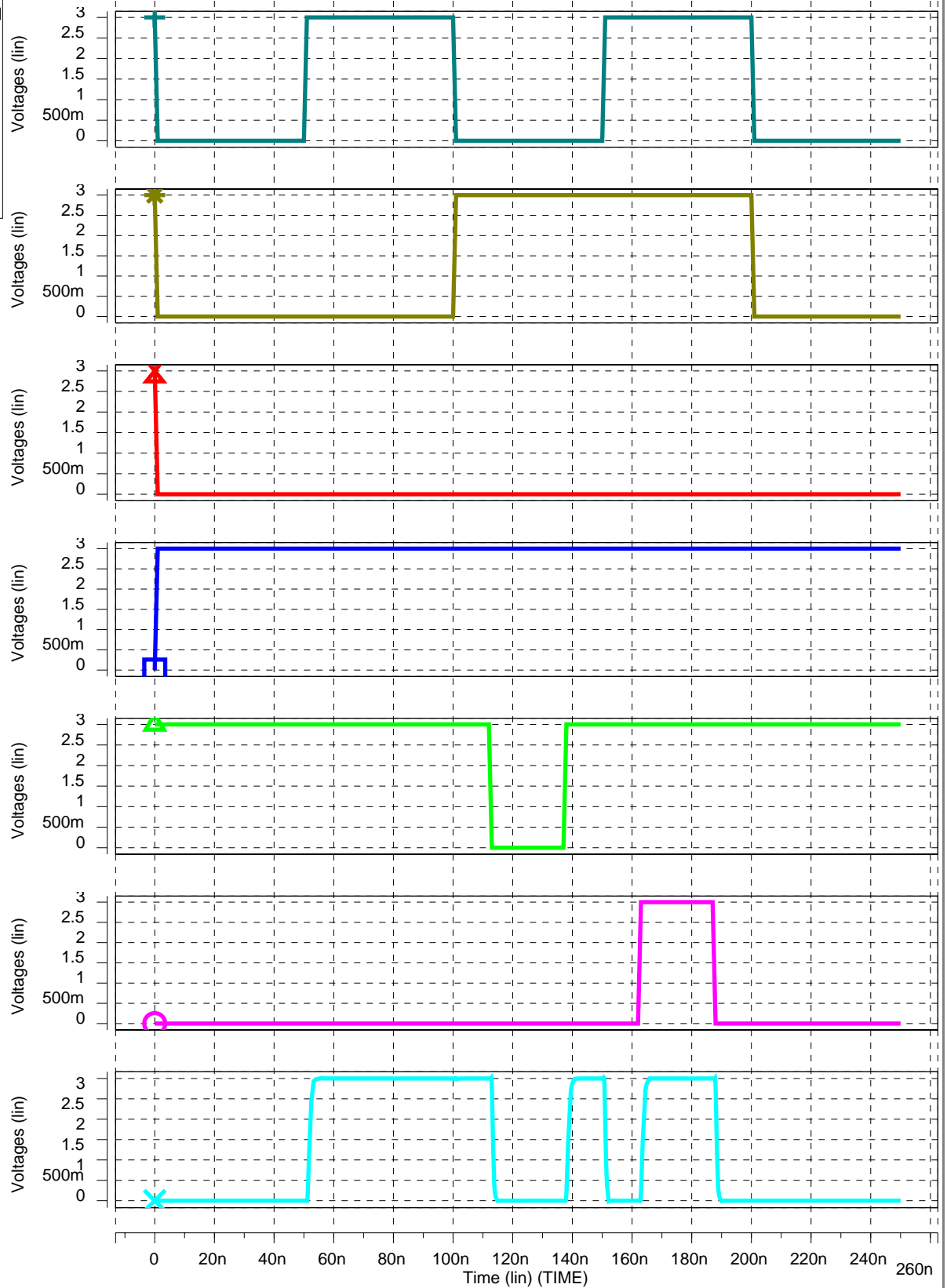

mux8to1_35

D

D

C

C

B

B

A

A

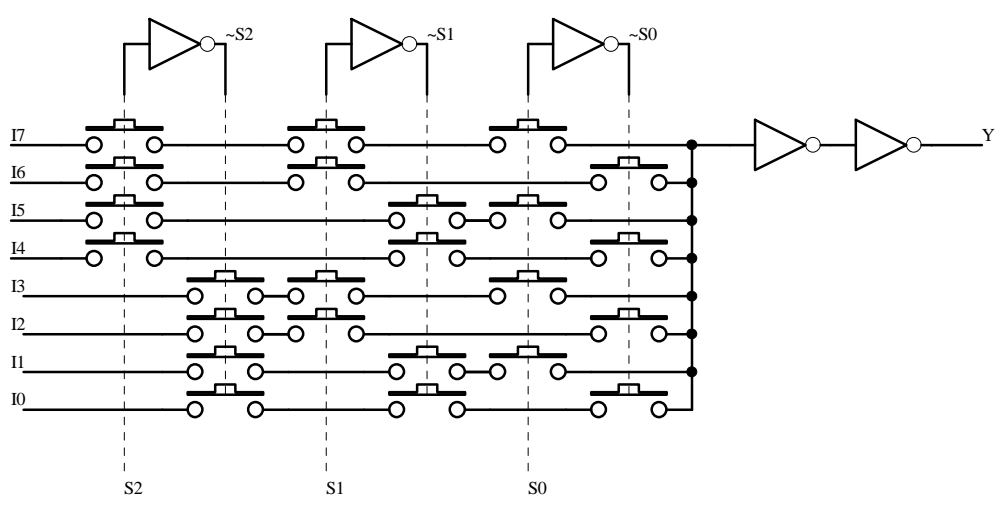
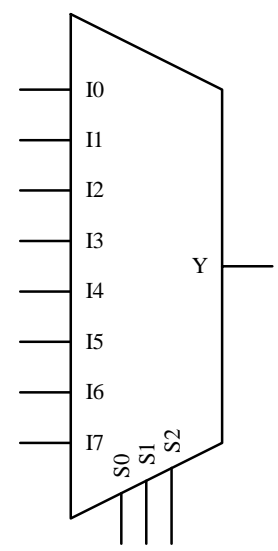
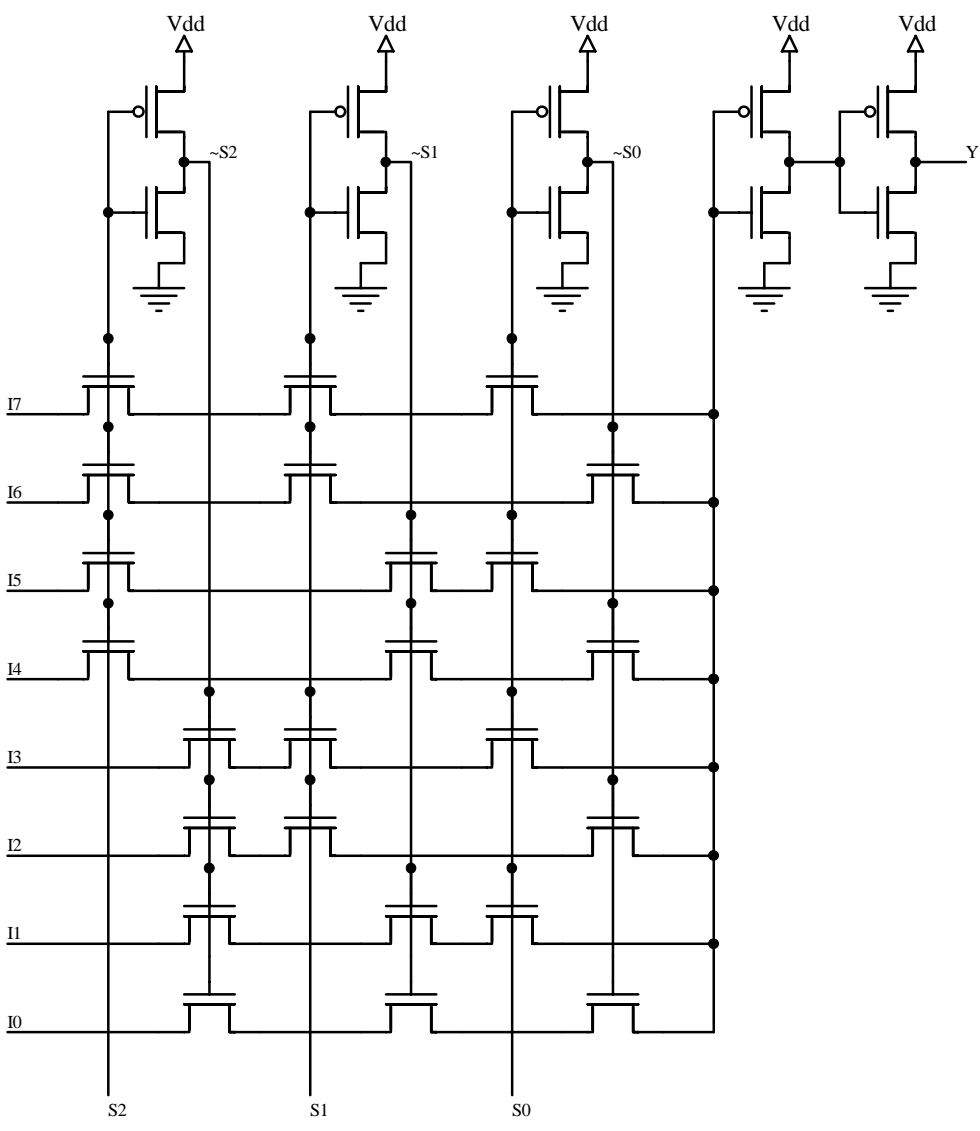

1

2

3

4

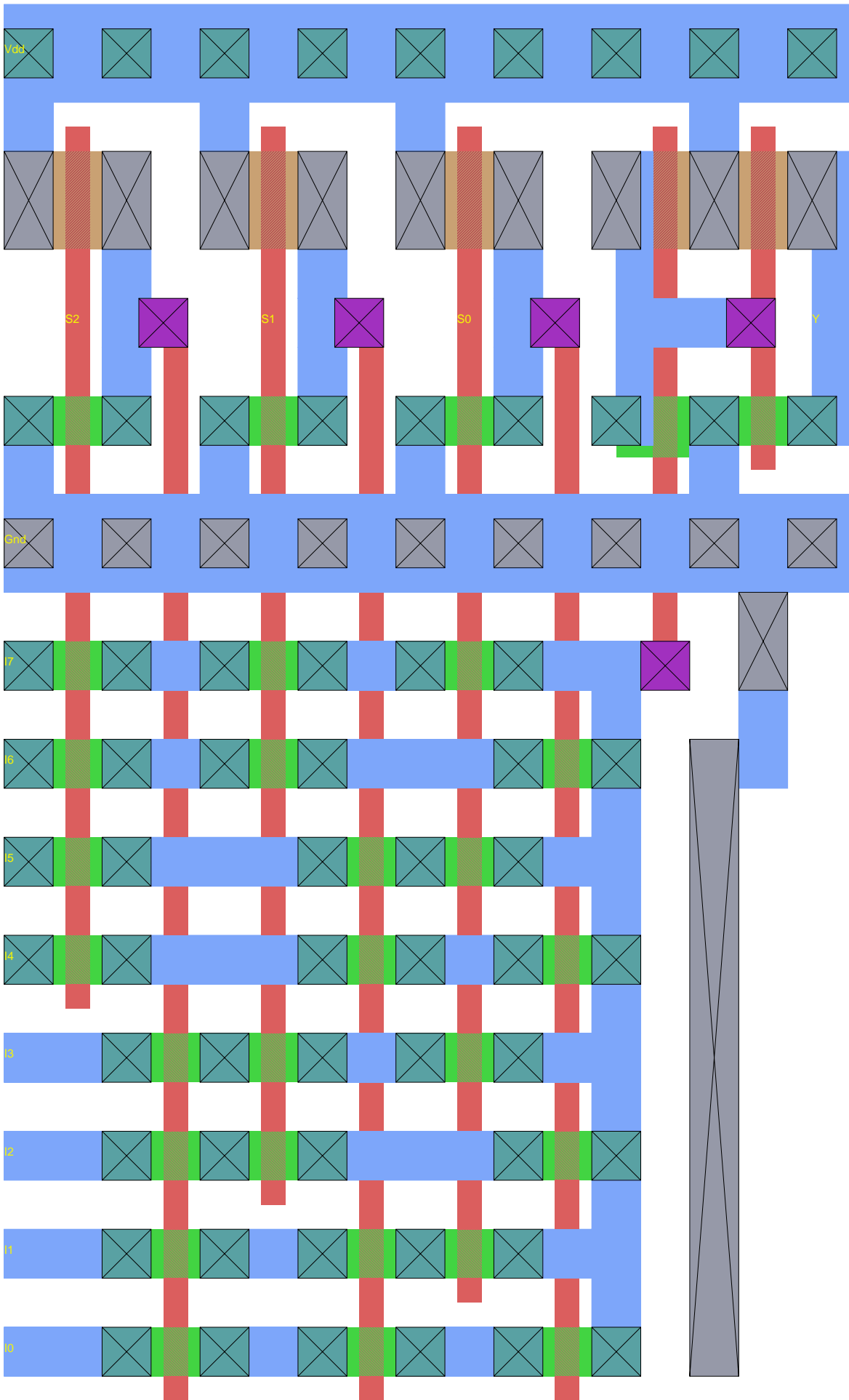

* hspice file created from mux8to1_35.ext - technology

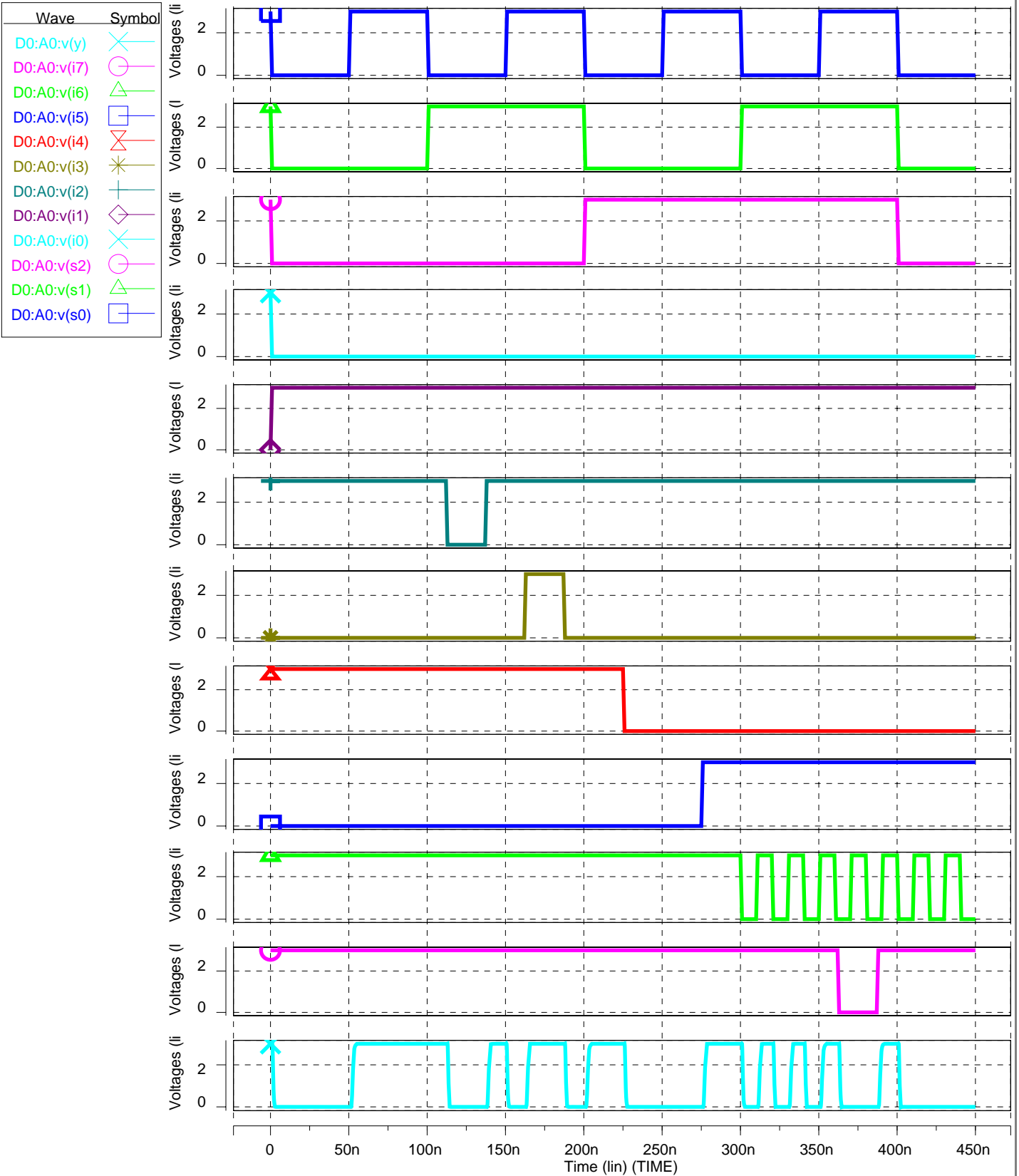

mux16to1_35

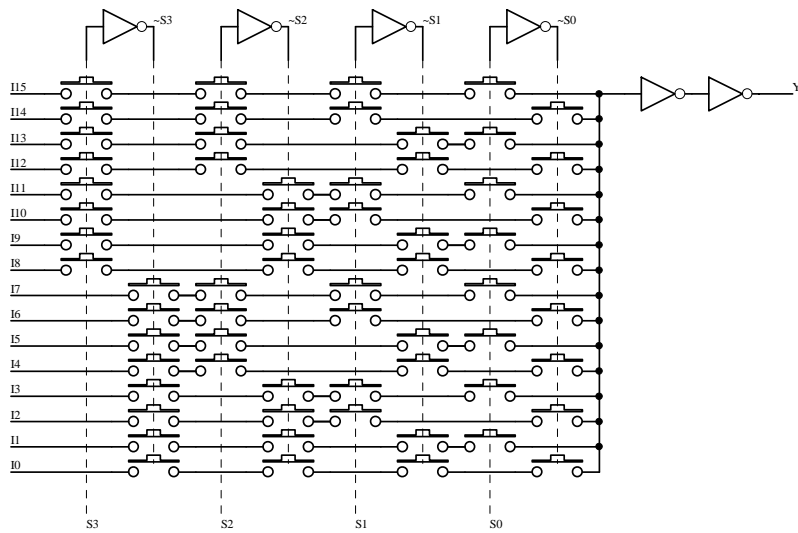
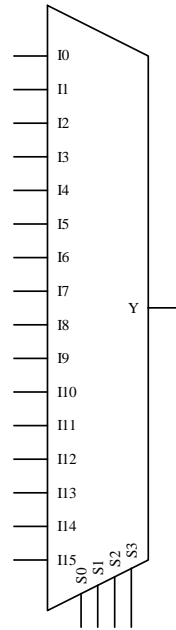
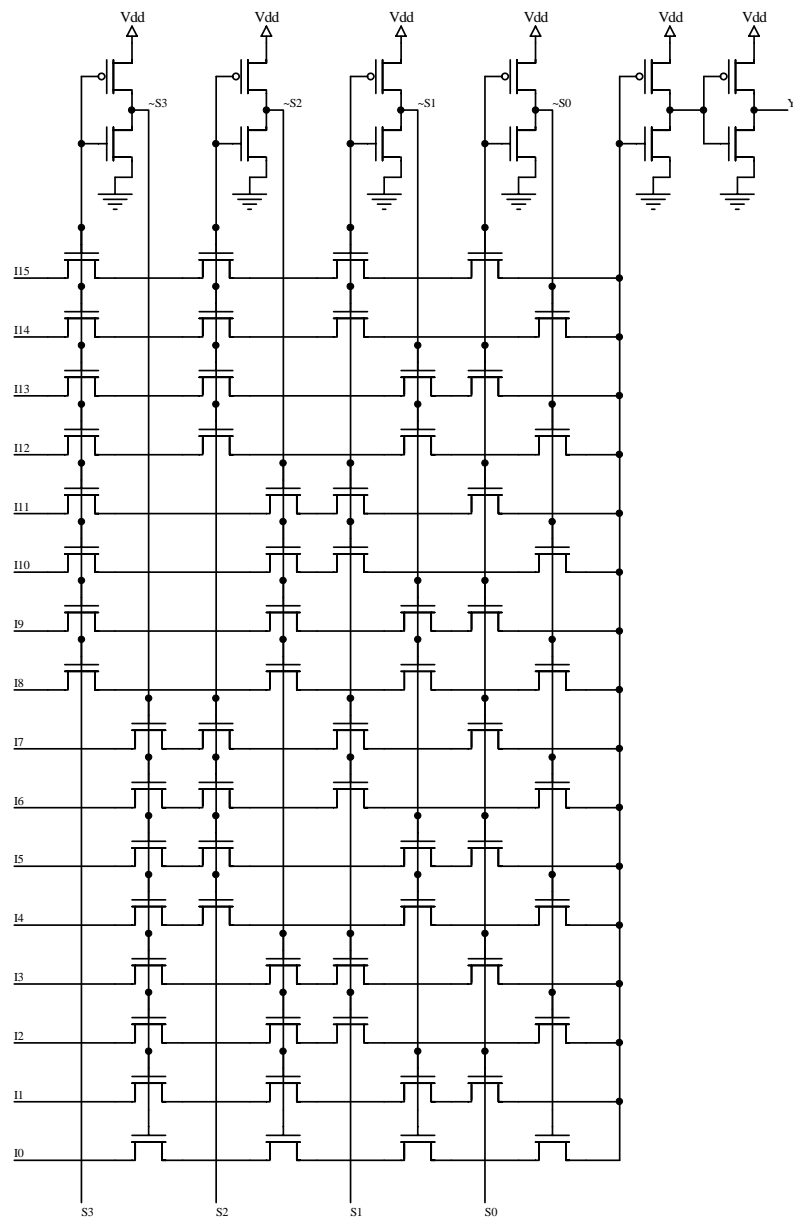

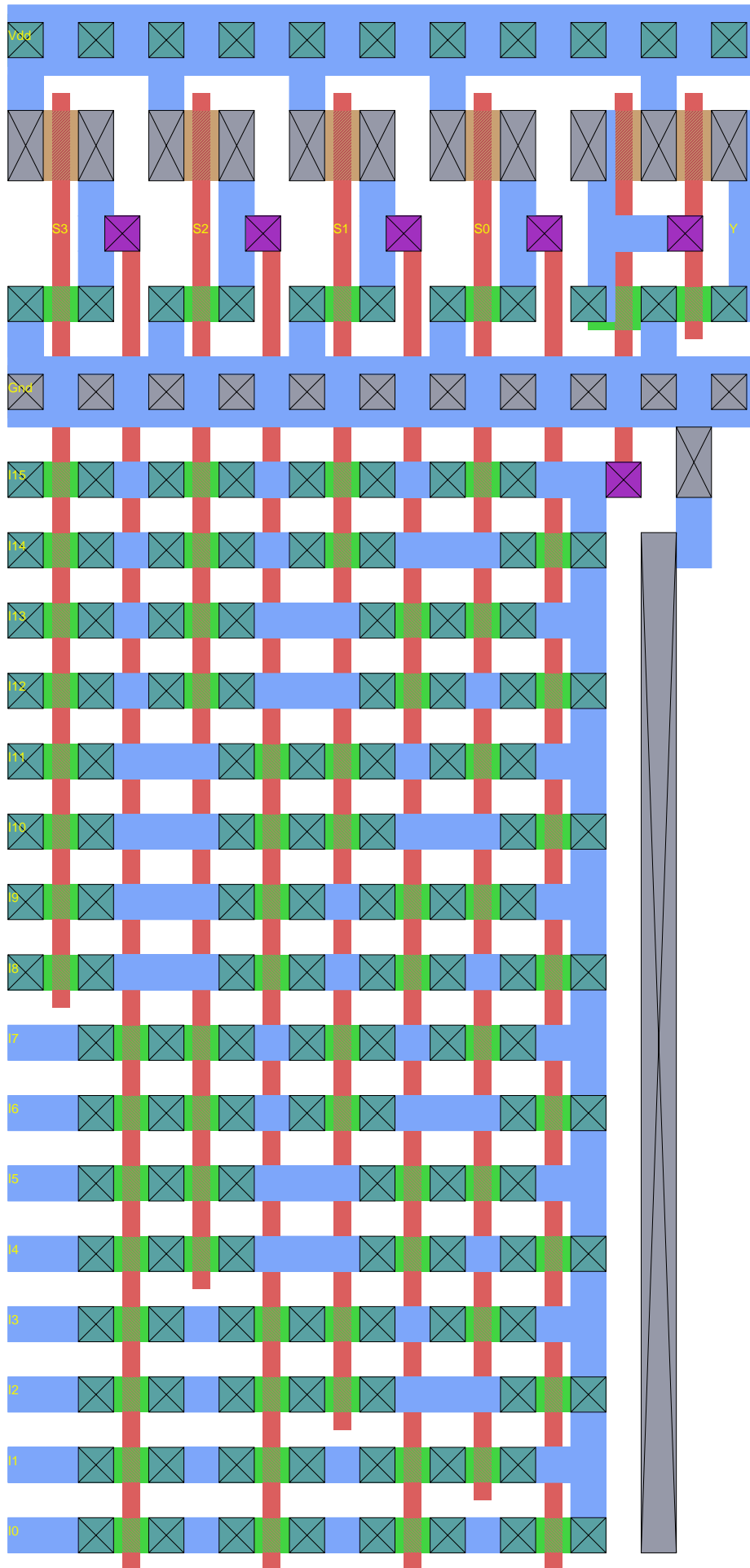

* hspice file created from mux16to1_35.ext - technolo

| Wave | Symbol |
|--------------|--------|
| D0:A0:v(y) | X |
| D0:A0:v(i15) | ○ |
| D0:A0:v(i14) | △ |
| D0:A0:v(i13) | □ |
| D0:A0:v(i12) | ⊗ |
| D0:A0:v(i11) | * |
| D0:A0:v(i10) | + |
| D0:A0:v(i9) | ◇ |
| D0:A0:v(i8) | X |
| D0:A0:v(i7) | ○ |
| D0:A0:v(i6) | △ |
| D0:A0:v(i5) | □ |
| D0:A0:v(i4) | ⊗ |
| D0:A0:v(i3) | * |
| D0:A0:v(i2) | + |
| D0:A0:v(i1) | ◇ |
| D0:A0:v(i0) | X |
| D0:A0:v(s3) | ○ |
| D0:A0:v(s2) | △ |
| D0:A0:v(s1) | □ |
| D0:A0:v(s0) | ⊗ |

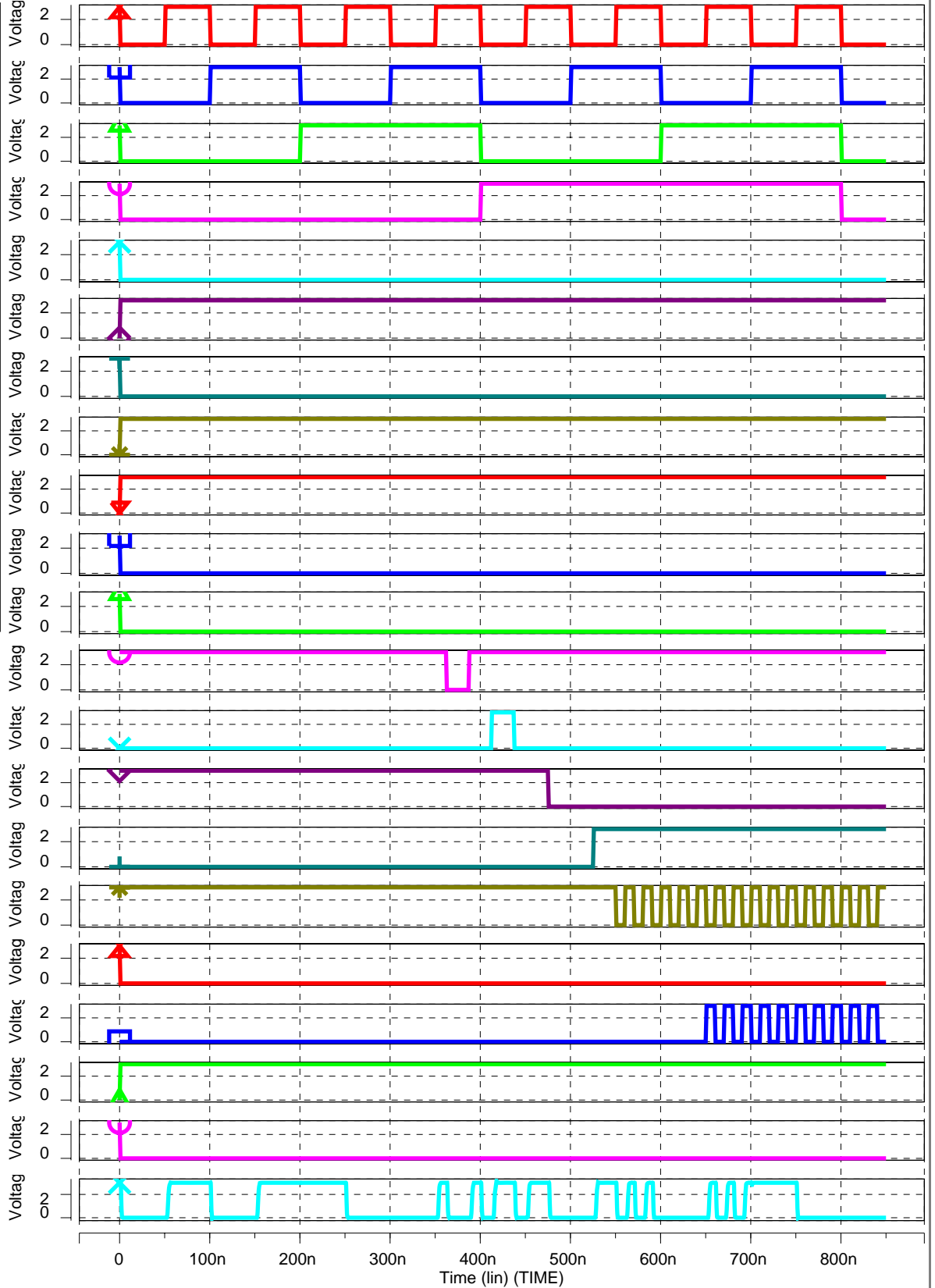

1

2

3

4

dec2to4_35

D

D

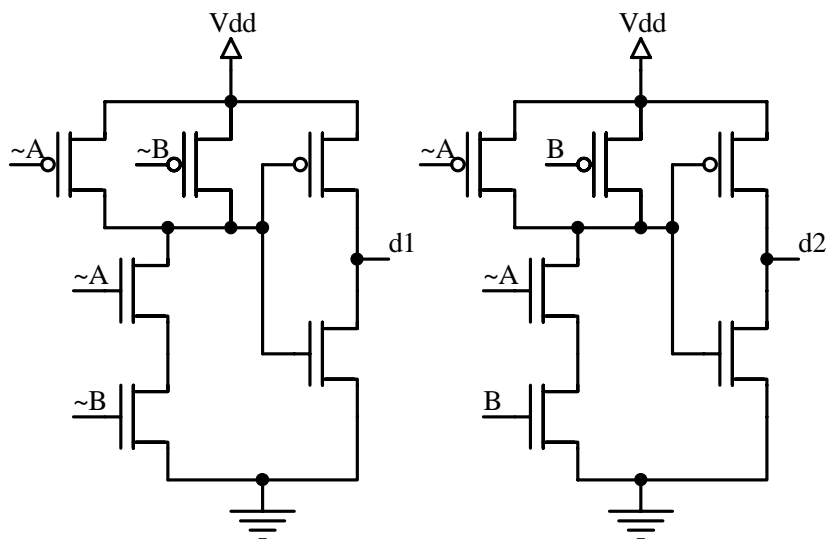

C

C

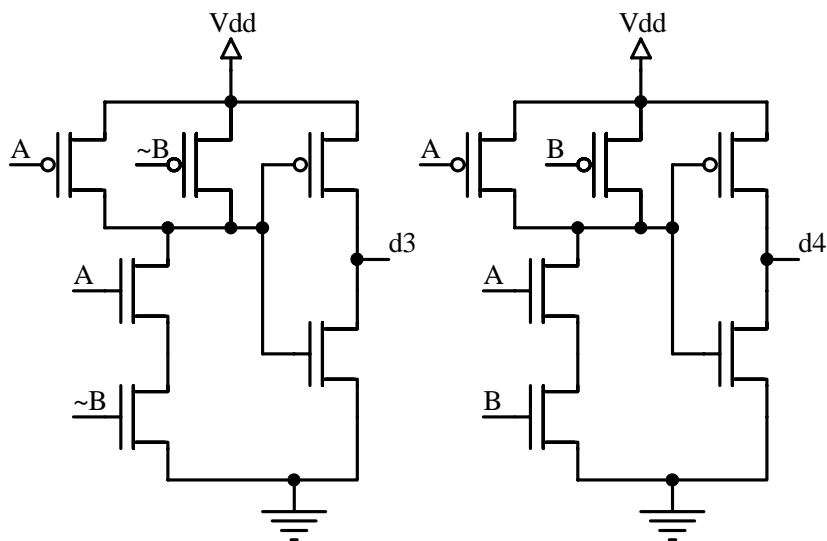

B

B

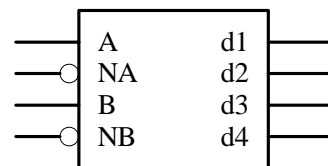
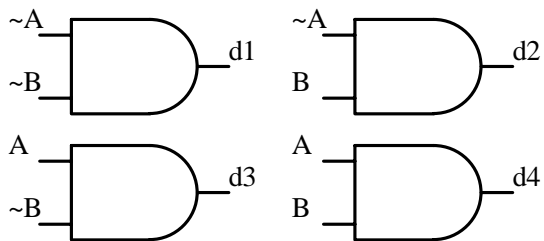

A

A

1

2

3

4

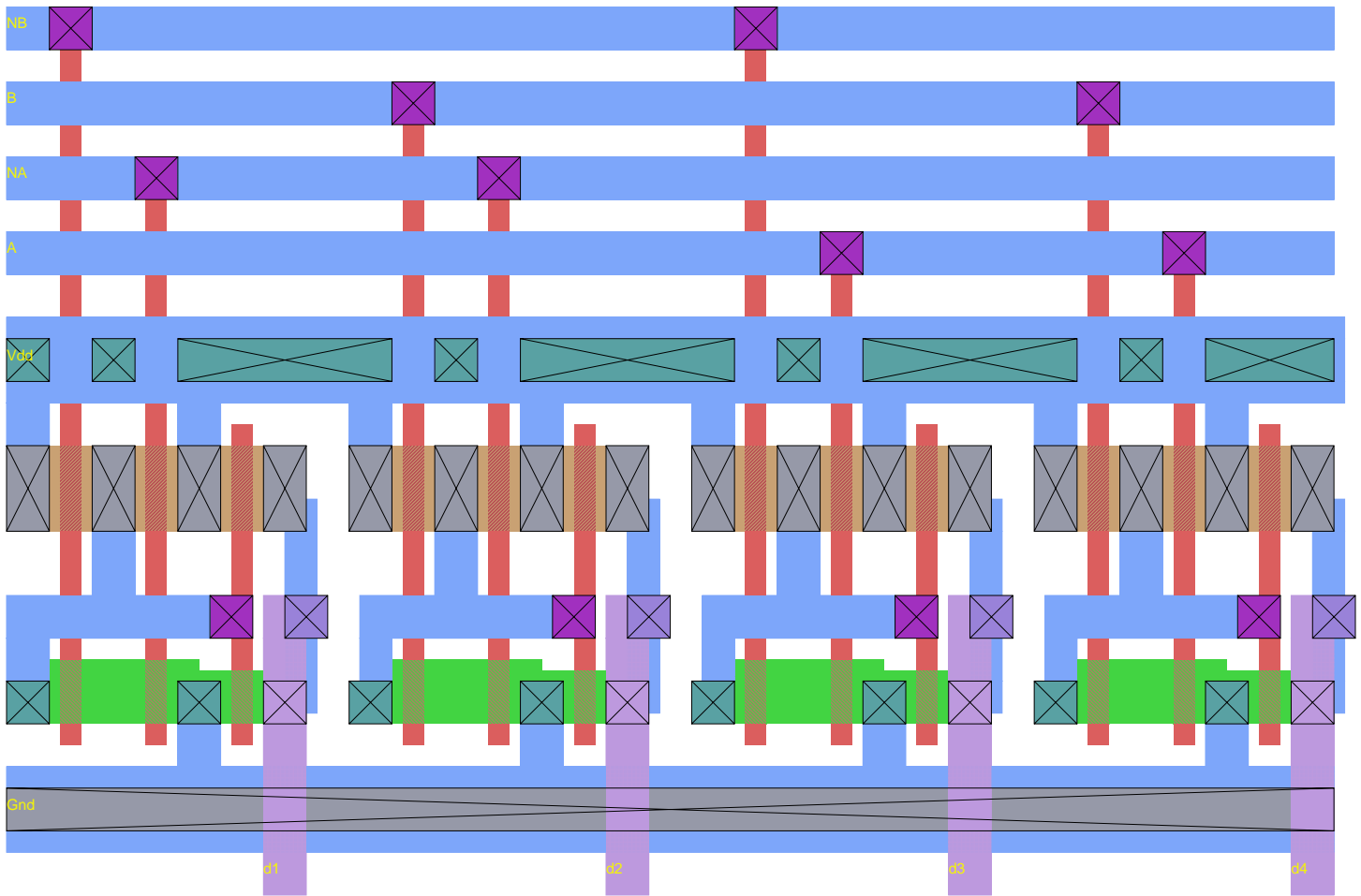

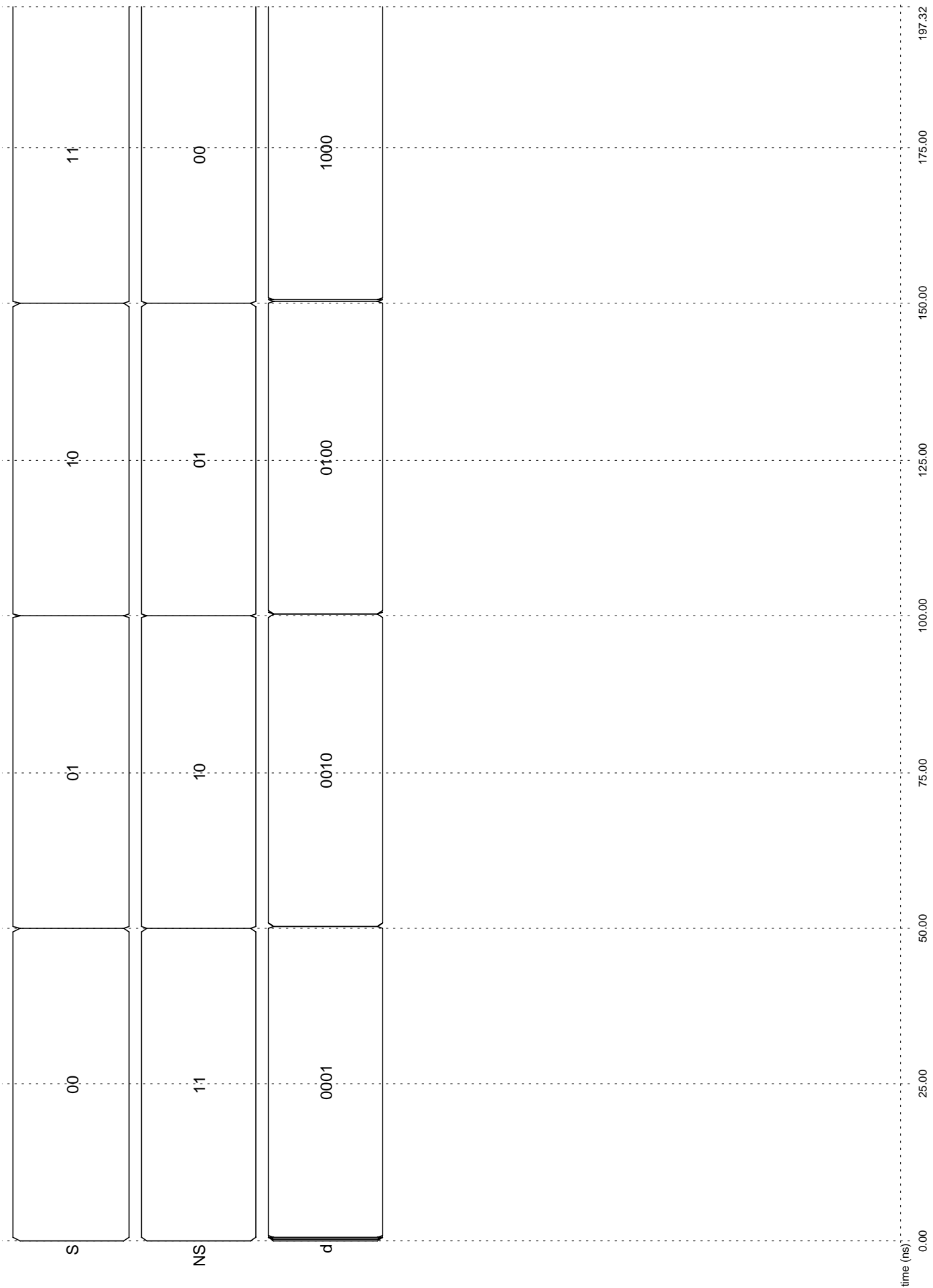

dec4to16_35

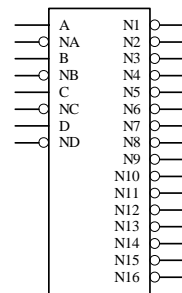
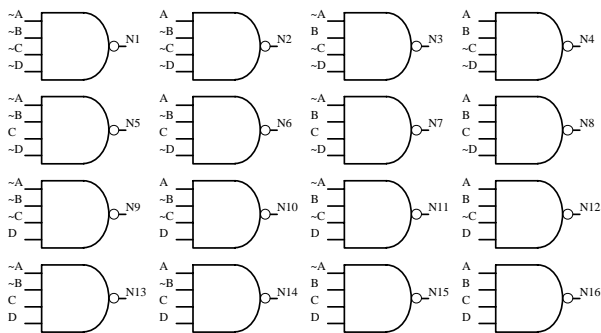
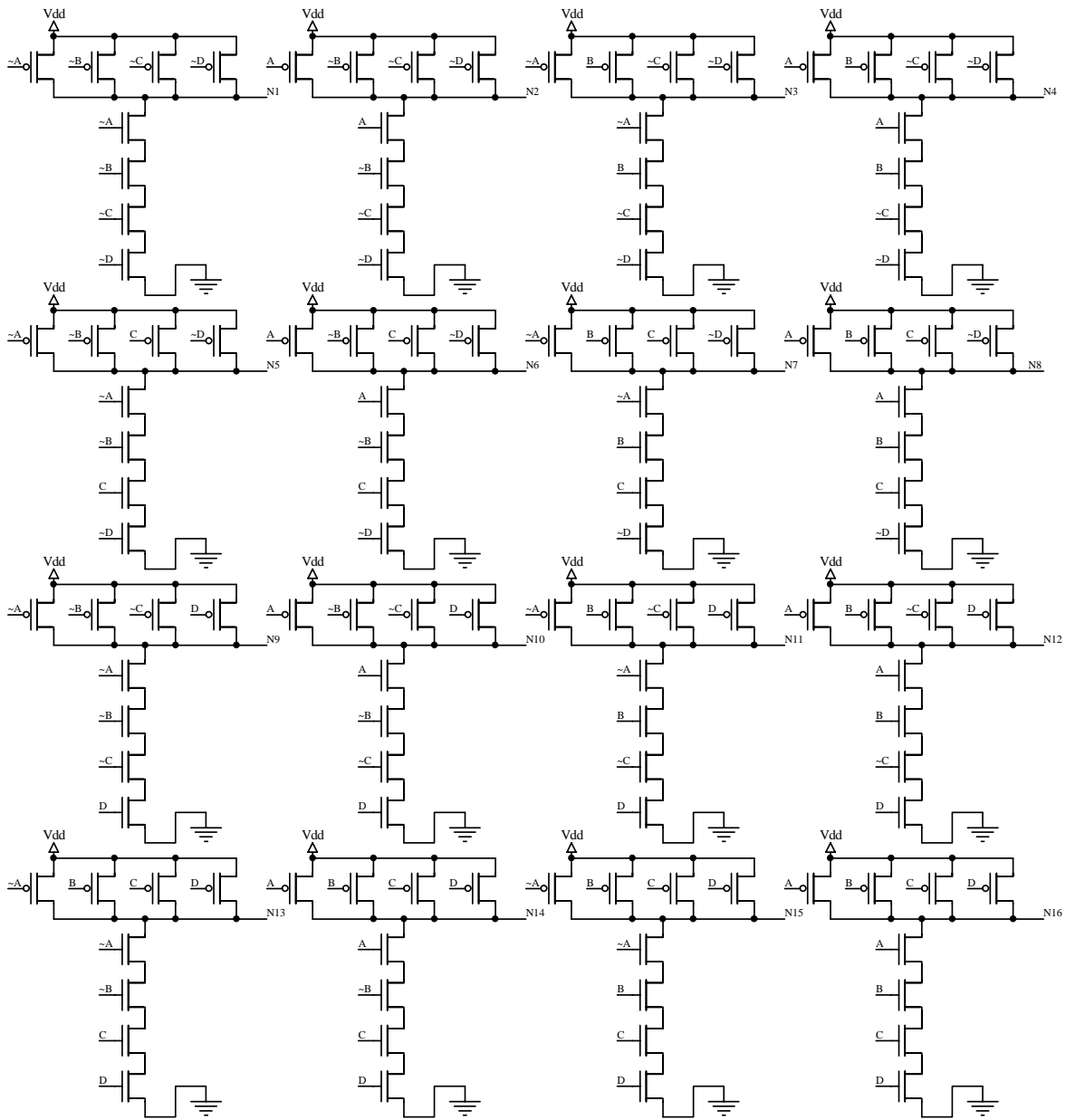

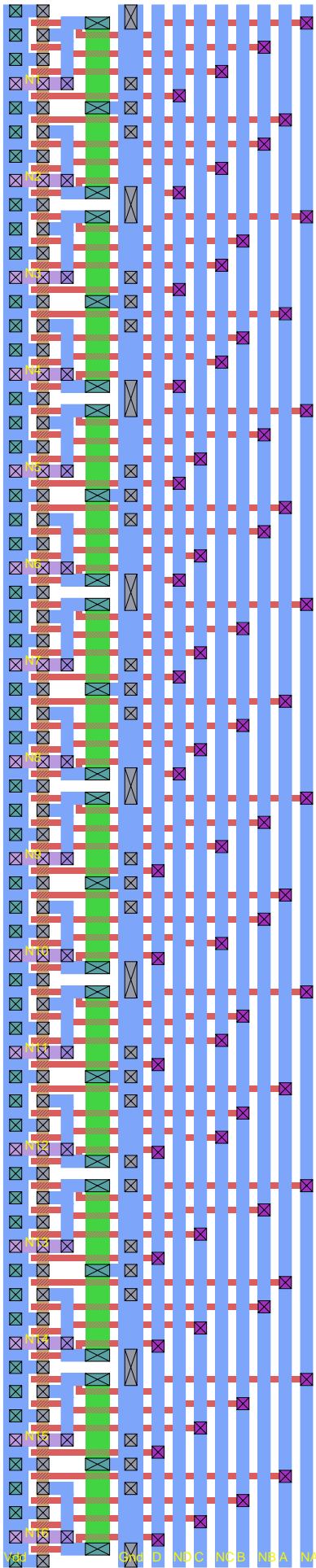

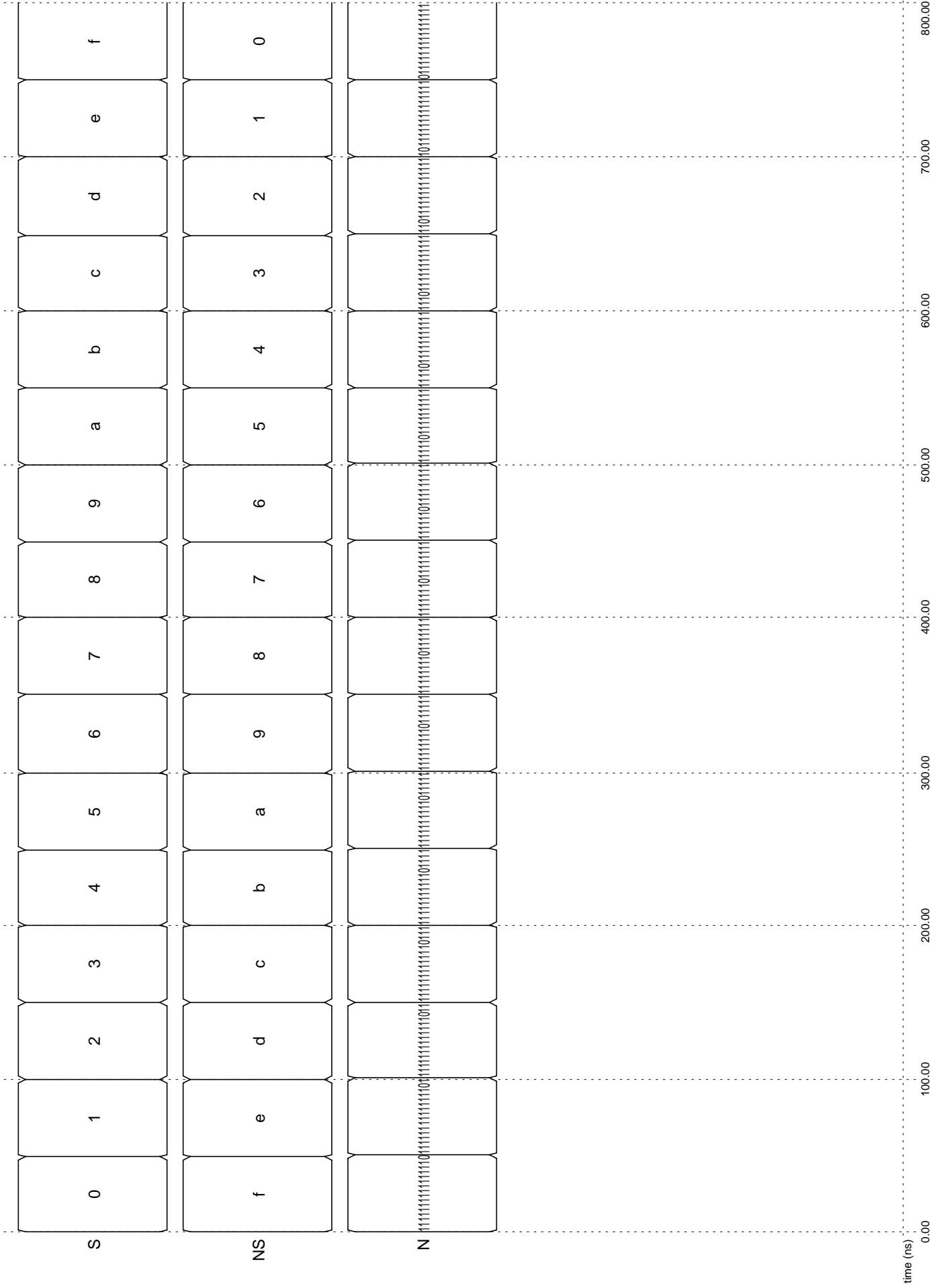

* hspice file created from dec4to16_35.ext - technology: scmos

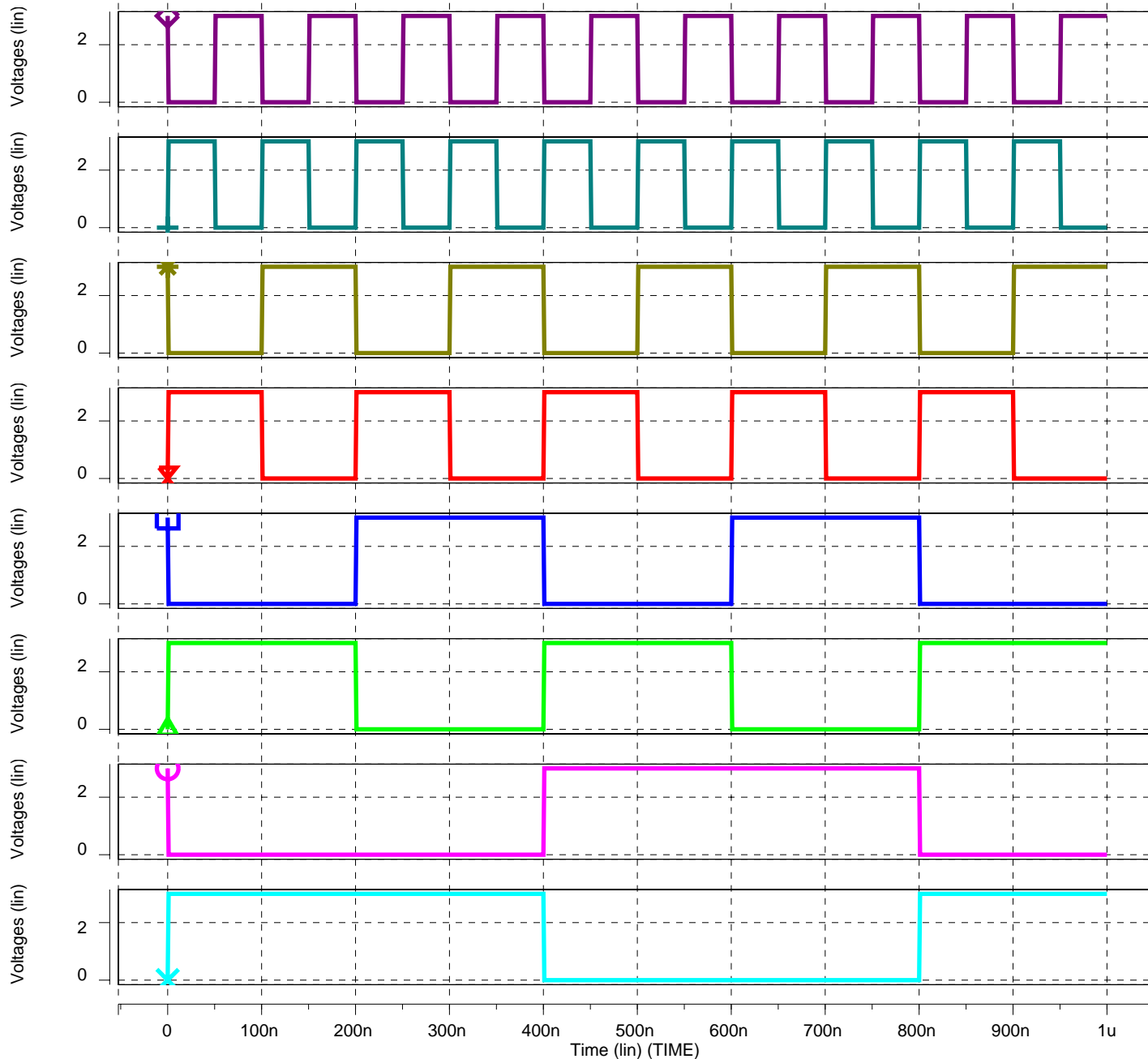

| Design | Type | Wave | Symbol |
|---|-----------|-------------|--------|
| D0: /grads/mr/public/tech35/dec4to16_35 | Transient | D0:A0:v(nd) | + |
| D0: /grads/mr/public/tech35/dec4to16_35 | Transient | D0:A0:v(d) | o |
| D0: /grads/mr/public/tech35/dec4to16_35 | Transient | D0:A0:v(nc) | ^ |
| D0: /grads/mr/public/tech35/dec4to16_35 | Transient | D0:A0:v(c) | □ |
| D0: /grads/mr/public/tech35/dec4to16_35 | Transient | D0:A0:v(nb) | x |
| D0: /grads/mr/public/tech35/dec4to16_35 | Transient | D0:A0:v(b) | * |
| D0: /grads/mr/public/tech35/dec4to16_35 | Transient | D0:A0:v(na) | + |
| D0: /grads/mr/public/tech35/dec4to16_35 | Transient | D0:A0:v(a) | ◇ |

Panel 2

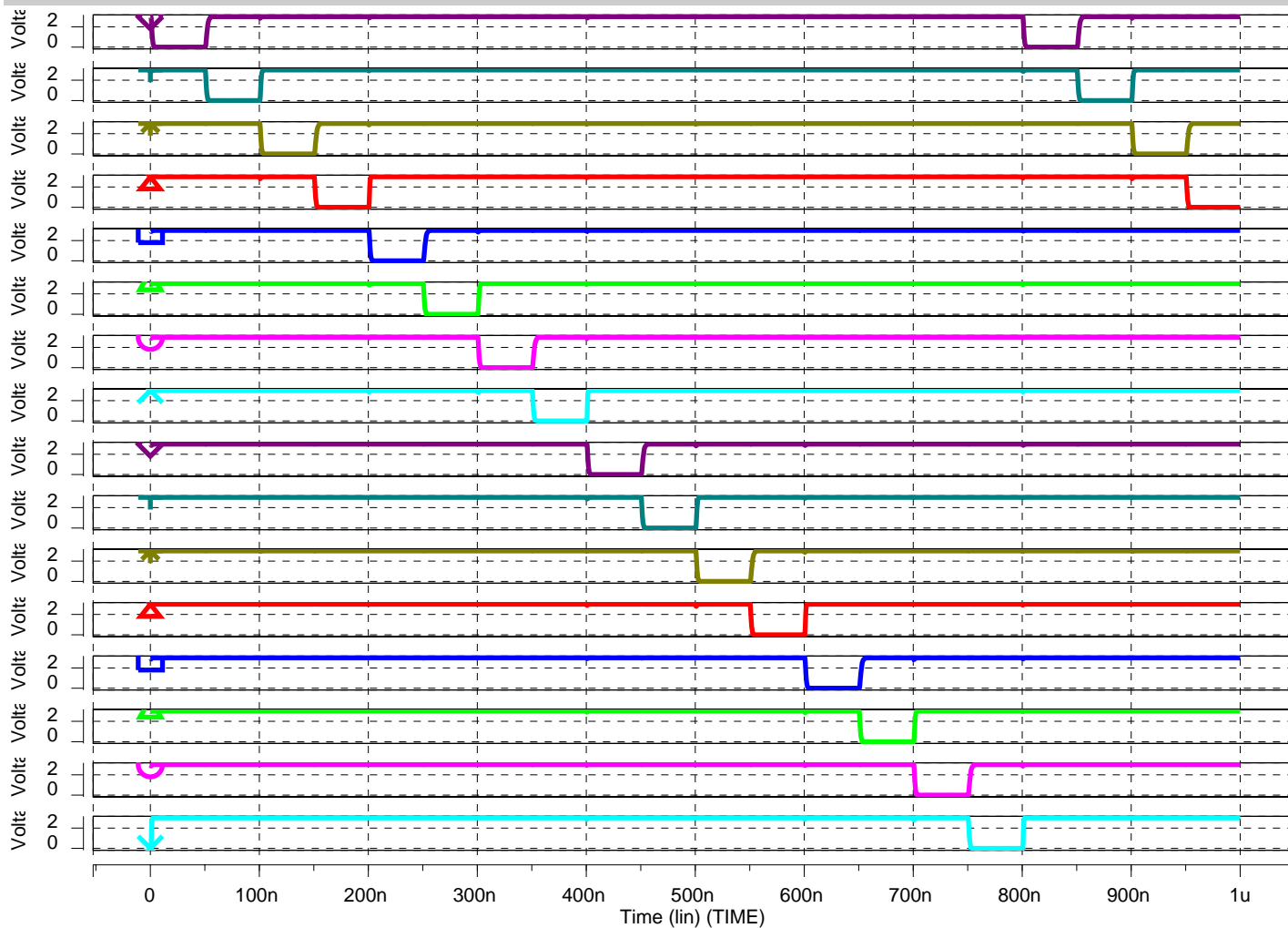

| Design | Type | Wave | Symbol |
|---|-----------|--------------|--------|
| D0: /grads/mr/public/tech35/dec4to16_35 | Transient | D0:A0:v(n16) | ⊗ |
| D0: /grads/mr/public/tech35/dec4to16_35 | Transient | D0:A0:v(n15) | ⊙ |
| D0: /grads/mr/public/tech35/dec4to16_35 | Transient | D0:A0:v(n14) | △ |
| D0: /grads/mr/public/tech35/dec4to16_35 | Transient | D0:A0:v(n13) | □ |
| D0: /grads/mr/public/tech35/dec4to16_35 | Transient | D0:A0:v(n12) | ⊗ |
| D0: /grads/mr/public/tech35/dec4to16_35 | Transient | D0:A0:v(n11) | * |
| D0: /grads/mr/public/tech35/dec4to16_35 | Transient | D0:A0:v(n10) | + |
| D0: /grads/mr/public/tech35/dec4to16_35 | Transient | D0:A0:v(n9) | ◇ |
| D0: /grads/mr/public/tech35/dec4to16_35 | Transient | D0:A0:v(n8) | ⊗ |
| D0: /grads/mr/public/tech35/dec4to16_35 | Transient | D0:A0:v(n7) | ⊙ |
| D0: /grads/mr/public/tech35/dec4to16_35 | Transient | D0:A0:v(n6) | △ |
| D0: /grads/mr/public/tech35/dec4to16_35 | Transient | D0:A0:v(n5) | □ |
| D0: /grads/mr/public/tech35/dec4to16_35 | Transient | D0:A0:v(n4) | ⊗ |
| D0: /grads/mr/public/tech35/dec4to16_35 | Transient | D0:A0:v(n3) | * |
| D0: /grads/mr/public/tech35/dec4to16_35 | Transient | D0:A0:v(n2) | + |
| D0: /grads/mr/public/tech35/dec4to16_35 | Transient | D0:A0:v(n1) | ◇ |